

MATHEMATICS

EXEMPLAR PROBLEMS

Class IX



राष्ट्रीय शैक्षिक अनुसंधान और प्रशिक्षण परिषद्
NATIONAL COUNCIL OF EDUCATIONAL RESEARCH AND TRAINING

FOREWORD

The National Curriculum Framework (NCF) – 2005 initiated a new phase of development of syllabi and textbooks for all stages of school education. Conscious effort has been made to discourage rote learning and to diffuse sharp boundaries between different subject areas. This is well in tune with the NPE – 1986 and *Learning Without Burden-1993* that recommend child centred system of education. The textbooks for Classes IX and XI were released in 2006 and for Classes X and XII in 2007. Overall the books have been well received by students and teachers.

NCF–2005 notes that treating the prescribed textbooks as the sole basis of examination is one of the key reasons why other resources and sites of learning are ignored. It further reiterates that the methods used for teaching and evaluation will also determine how effective these textbooks proves for making children’s life at school a happy experience, rather than source of stress or boredom. It calls for reform in examination system currently prevailing in the country.

The position papers of the National Focus Groups on *Teaching of Science, Teaching of Mathematics and Examination Reform* envisage that the mathematics question papers, set in annual examinations conducted by the various Boards do not really assess genuine understanding of the subjects. The quality of questions papers is often not up to the mark. They usually seek mere information based on rote memorization, and fail to test higher-order skills like reasoning and analysis, let alone lateral thinking, creativity, and judgment. Good unconventional questions, challenging problems and experiment-based problems rarely find a place in question papers. In order to address to the issue, and also to provide additional learning material, the Department of Education in Science and Mathematics (DESM) has made an attempt to develop resource book of exemplar problems in different subjects at secondary and higher-secondary stages. Each resource book contains different types of questions of varying difficulty level. Some questions would require the students to apply simultaneously understanding of more than one chapters/units. These problems are *not* meant to serve merely as question bank for examinations but are primarily meant to improve the quality of teaching/learning process in schools. It is expected that these problems would encourage teachers to design quality questions on their own. Students and teachers should always keep in mind that examination and assessment should test

comprehension, information recall, analytical thinking and problem-solving ability, creativity and speculative ability.

A team of experts and teachers with an understanding of the subject and a proper role of examination worked hard to accomplish this task. The material was discussed, edited and finally included in this source book.

NCERT will welcome suggestions from students, teachers and parents which would help us to further improve the quality of material in subsequent editions.

New Delhi
21 May 2008

Professor Yash Pal
Chairperson
National Steering Committee
National Council of Educational
Research and Training

PREFACE

The Department of Education in Science and Mathematics (DESM), National Council of Educational Research and Training (NCERT), initiated the development of 'Exemplar Problems' in science and mathematics for secondary and higher secondary stages after completing the preparation of textbooks based on National Curriculum Framework–2005.

The main objective of the book on 'Exemplar Problems in Mathematics' is to provide the teachers and students a large number of quality problems with varying cognitive levels to facilitate teaching learning of concepts in mathematics that are presented through the textbook for Class IX. It is envisaged that the problems included in this volume would help the teachers to design tasks to assess effectiveness of their teaching and to know about the achievement of their students besides facilitating preparation of balanced question papers for unit and terminal tests. The feedback based on the analysis of students responses may help the teachers in further improving the quality of classroom instructions. In addition, the problems given in this book are also expected to help the teachers to perceive the basic characteristics of good quality questions and motivate them to frame similar questions on their own. Students can benefit themselves by attempting the exercises given in the book for self assessment and also in mastering the basic techniques of problem solving. Some of the questions given in the book are expected to challenge the understanding of the concepts of mathematics of the students and their ability to applying them in novel situations.

The problems included in this book were prepared through a series of workshops organised by the DESM for their development and refinement involving practicing teachers, subject experts from universities and institutes of higher learning, and the members of the mathematics group of the DESM whose names appear separately. We gratefully acknowledge their efforts and thank them for their valuable contribution in our endeavour to provide good quality instructional material for the school system.

I express my gratitude to Professor Krishna Kumar, *Director* and Professor G.Ravindra, *Joint Director*, NCERT for their valuable motivation and guidance from time to time. Special thanks are also due to Dr. R.P.Maurya, *Reader* in Mathematics, DESM for coordinating the programme, taking pains in editing and refinement of problems and for making the manuscript pressworthy.

We look forward to feedback from students, teachers and parents for further improvement of the contents of this book.

Hukum Singh
Professor and Head

DEVELOPMENT TEAM
EXEMPLAR PROBLEMS – MATHEMATICS

MEMBERS

G. P. Dikshit, *Professor (Retd.)*, Lucknow University, Lucknow

Hukum Singh, *Professor and Head*, DESM, NCERT, New Delhi

J.C. Nijhawan, *Principal (Retd.)*, Directorate of Education, Delhi

Jharna De, *T.GT.*, Dev Samaj Hr. Secondary School, Nehru Nagar

Mahendra Shankar, *Lecturer (S.G) (Retd.)*, DESM, NCERT, New Delhi

P. Sinclair, *Professor and Pro Vice Chancellor*, IGNOU, New Delhi

Ram Avtar, *Professor (Retd.)*, DESM, NCERT, New Delhi

Sanjay Mudgal, *Lecturer*, DESM, NCERT, New Delhi

Vandita Kalra, *Lecturer*, Sarvodaya Kanya Vidyalaya, Vikaspuri District Centre,
New Delhi

V.P. Singh, *Reader*, DESM, NCERT, New Delhi

MEMBER - COORDINATOR

R.P. Maurya, *Reader*, DESM, NCERT, New Delhi

ACKNOWLEDGEMENTS

The Council gratefully acknowledges the valuable contributions of the following participants of the Exemplar Problems Workshop:

V.Madhavi, *TGT*, Sanskriti School, Chanakyapuri, New Delhi; Mohammad Qasim, *TGT*, Anglo Arabic Senior Secondary School, Ajmeri Gate, Delhi; Ajay Kumar Singh, *TGT*, Ramjas Senior Secondary School No. 3, Chandani Chowk, Delhi; Chander Shekhar Singh, *TGT*, Sunbeam Academy School, Durgakund, Varanasi; P.K.Tiwari, *Assistant Commissioner (Retd.)*, Kendriya Vidyalaya Sangathan, New Delhi and P.K.Chaurasia, *Lecturer*, DESM, NCERT, New Delhi.

Special thanks are due to Professor Hukum Singh, *Head*, DESM, NCERT for his support during the development of this book.

The Council also acknowledges the efforts of Deepak Kapoor, *Incharge*, Computer Station; Rakesh Kumar, Inder Kumar and Sajjad Haider Ansari, *DTP Operators*; Abhimanu Mohanty, *Proof Reader*.

The contribution of APC Office, Administration of DESM, Publication Department and Secretariat of NCERT is also duly acknowledged.

STUDENTS' EVALUATION IN MATHEMATICS AT SECONDARY STAGE

A. Introduction

The fascinating world of mathematics provides an unlimited scope to mathematicians to perceive problems pertaining to three situations visualised in the forms of concrete, abstraction and intuition. However, due to abstraction and intuition, sometimes some of the mathematical concepts become quite complicated even for teachers who are actively engaged in mathematics teaching at various stages. This needs the exhaustive training in methods/ pedagogy as well as in contents. This also needs the clarifications of mathematical concepts using instructional materials, experimentation, observation and practicals etc. to avoid the abstraction at various stages of schooling. Good mathematics instruction requires good teachers, and good teachers are those with pedagogical content knowledge who, in turn, are predominantly those with good content. Improvement of school mathematics education therefore begins with teaching teachers the mathematics they need. In other words, the most difficult demand for becoming a good teacher is to achieve a firm mastery of the mathematical content. Without such a mastery, good pedagogy is difficult. A firm mastery of the content opens up the world of pedagogy and offers many more effective pedagogical possibilities. Even best pedagogy lavished on incorrect mathematics may result in poor quality in teaching.

Mathematics as a science of abstract objects, relies on *logic* rather than on observation, yet it employs observation, simulation, and even experiments as means of discovering truth. The ability to reason and think clearly is extremely useful in our daily life, that is, developing children's abilities for *mathematisation* is the main goal of mathematics education as has been emphasised in National Curriculum Framework-2005 (NCF-2005). It is in this content that NCF-2005 has set two distinct targets for mathematics education at school level viz. *narrow* and *higher*. The narrow aim of school mathematics is to develop useful capabilities, particularly those relating to numeracy- number, number operations, measurements, decimals and percentages. The higher aim is to develop the child's resources to think and reason mathematically, to pursue assumptions to their logical conclusions and to handle abstractions. It includes a way of doing things, and the ability and the attitude to formulate and solve problems. This calls for curriculum to be ambitious in the sense that it seeks to achieve the higher aim mentioned above, rather than only the narrow aim. It should be coherent in

the sense that the variety of methods and skills available piecemeal (in arithmetic, algebra, geometry) cohere into an ability to address problems that come from other domains such as sciences and in social studies at secondary stage. It should be important in the sense that students feel the need to solve such problems.

Evaluation is a very comprehensive term which, in general, includes evaluating any object, individual, event, trend, etc. A most common type of individual evaluation is the evaluation of a student. It includes the assessments of the performance of the student in the areas of her personality development in terms of intellectual, social and emotional developments after she has been provided learning experiences through classroom processes. Besides the factors like quality of teaching curricular materials, instructional technology, school infrastructure and societal support also influence the learning and experiences. In educational terminology, these areas of personality development are called scholastic and co-scholastic areas. Due to its wider applications in various other fields, mathematics is the most important scholastic area. It is for this reason, mathematics is a compulsory subject up to the secondary stage from quite a long time. This is the stage which acts as a bridge between the students who will continue with Mathematics in higher classes. Therefore, evaluation of Mathematics at this stage requires special attention. This evaluation is done to assess whether the main aim or objectives laid down in NCF-2005 have been achieved by the students or not?

B. Purposes of Evaluation

There are various purposes of evaluation. Some of these are to know the answers for the following questions:

- (i) How has the teaching been effective?
- (ii) Which method is more suitable for teaching a particular topic or concept?
- (iii) To what extent students are ready to learn a particular topic?
- (iv) What type of learning difficulties are faced by the students?
- (v) Do the students require remedial measures?
- (vi) Which students are to be provided some enrichment materials?
- (vii) Which topics are more difficult for the student?
- (viii) Is there a need to make a change in the teaching strategy for a particular topic?
- (ix) How can the result of the evaluation can be utilised for the all round development of students?

C. Types of Evaluation

Evaluation is mainly of two types namely

(i) **Summative** and (ii) **Formative**

- (i) **Summative Evaluation:** It is done at the end of the course or a term. It involves a formal testing of the student's achievements and is used for grading, ranking and certifying the achievements of the students.
- (ii) **Formative Evaluation:** It is in-built in the teaching learning process. It is a continuous process going on throughout the course. The purpose of such evaluation is to obtain feedback so that teaching or instructional strategies could be improved. Further, on the basis of the feedback, strategies and weaknesses of the students can be assessed.

NCF-2005 has also given more stress on continuous and comprehensive evaluation in comparison to the summative evaluation. For this, a mathematics teacher may

- (i) ask some questions to know to what extent the students understand about the new concept to be taught before it is started.
- (ii) ask question at regular intervals to check the understanding of students during the presentation of a concept.
- (iii) assess students by the questions asked by them during the teaching of a chapter.
- (iv) assess the students during class work.
- (v) assess students on the basis of the home assignments given to them.
- (vi) assess students by asking some questions at the end of the chapter.
- (vii) encourage peer group members (students) to evaluate one another. This may be called as **Peer Evaluation**. This evaluation can bring out the hidden talents among the students.

Thus, whatever may be the way of evaluation, it is done through some well thought questions, which may be referred to as **good questions**.

D. Characteristics of a Good Question

Quality of a question depends on the situation where it is to be used. In general, following are some of the characteristics of a 'good question':

- (i) **Validity:** A question is said to be valid, if it serves the purpose for which it has been framed.

Thus, for a question to be valid, it must be based on (a) a specified extent area and also on (b) a predetermined aim or objective.

In case it is not valid, it will be treated as a question 'out of course or syllabus'.

(ii) **Reliability:** A question is said to be reliable, if its answer gives the true achievement of the student. In other words, the achievement of the student must be free from chance errors. These errors, generally, occur due to vagueness of language or direction provided in the question. They may occur (1) at the time when the student is answering the question and (2) at the time when the teacher is evaluating the answer. In view of the above, following steps can ensure higher reliability of a question:

- (a) The question should admit of one and only one interpretation.
- (b) The scope of the answer must be clear.
- (c) The directions to the question must be clear.
- (d) A well thought marking scheme should be provided for the question.

(iii) **Difficulty Level:** Difficulty level is a very important characteristic of a question. In different situations, questions of different difficulty levels are needed. For example, for assessing the achievement of Minimum Level of Learning, there will always be a need of questions of lower difficulty level. Difficulty level of a question may be categorised in the following three types:

- (a) **Difficult:** Which could be done by about less than 30% of the students.
- (b) **Average:** Which could be done by $\geq 30\%$ but $\leq 70\%$ of the students.
- (c) **Easy:** Which could be done by more than 70% of the students.

These levels can be decided by the question framer herself on the basis of her own experiences.

(iv) **Language:** Language of a question must be simple and within the comprehension level of the student's vocabulary. It should not lead to different answers. However, if necessary, the same question can be presented before the students at different difficulty levels, by using a little different language or wordings.

(v) **Form:** There are different forms of questions and each form is more suitable than the other depending upon the situations. There may be several factors for choosing a particular form of questions. There may be one or more of the following:

- (a) Economy (b) Facility in printings (c) Ease in scoring and so on.

E. Different Forms of questions

In general, the questions are of the following two forms:

- (1) Free Response Type and (2) Fixed Response Type

1. Free Response Questions: In a free response question, a student formulates and organizes her own answer. These type of questions are very much in use in the present system of examination. These are of two types, namely

(a) **Long Answer Questions**

A question which requires comparatively a lengthy answer is called a long answer type question. These questions require the student to select relevant facts, organise them and write answers in her own words. In these type of questions, there is a very little scope of guessing. However, if there are more number of long answer questions, then the possibility of covering the whole content area in the examination will become less. To overcome this difficulty, we may choose such long answer type questions which involve more than one content areas.

(b) **Short Answer Questions**

A question in which a student is expected to write the answer in 3 or 4 lines is called a short answer type question. In these question, the coverage of content areas is more specific and definite. It may be noted that a question whose answer may be a simple diagram is also considered to be a short answer type question.

2. Fixed Response Questions: In these type of questions, the answer is fixed and definite. These type of question are being encouraged due to their objectivity in scoring. They are also of two types, namely

(a) **Very Short Answer Questions**

A question in which a student is expected to give the answer in just one word or a phrase is called a very short answer type question. In mathematics, by a word or a phrase, we generally mean a group of symbols or numbers (numerals). It is expected to take 1 to 3 minutes to answer such a question. Fill in the blanks question is one of the examples of such type of questions.

(b) **Objective Questions**

An objective type question is one in which alternate answers are given and student has to just indicate the correct answer. These questions can also be answered in just 1 to 3 minutes. They can be further classified into the following forms:

(i) **True-False Type:** In these type of questions, a statement or formula is given and the student is expected to write whether it is 'True' or 'False'.

(ii) **Matching Type:** These type of questions consist of two columns. The student has to pair each item of first column with some item of the second column on the basis of some criterion. The number of items in the second column may be more than that of the first column.

(iii) **Sentence Completion Type:** In these type of questions, the student has to complete the given sentence using one or more words given in brackets along with the question.

(iv) **Multiple Choice Type:** In these type of questions, number of alternatives (usually called distracters), only one is appropriate or correct. The student is expected to write or tick (✓) the correct alternative.

In the fixed response questions, the scope guess work is very high. However, this can be minimised by attaching some element of reasoning in such questions. We may call these questions as **Short Answer Questions with Reasoning**.

F. Instructional Objectives

As already stated, a question is said to be valid if it also based on a predetermined objective. The word 'objective' is a tiered form. Objectives are divided into two groups, namely (1) educational objectives and (2) instructional objectives. Educational objectives play a directive role in the process of education, while instructional objectives are those goals for the achievement of which all educational efforts are directed. Mathematics is a special language with its own vocabulary and grammar. The vocabulary consists of concepts, terms, facts, symbols, assumptions, etc., while the grammar relates to principles, processes, functional relationships etc. Knowledge and understanding of these and their applications to new situations have helped mankind to achieve tremendous progress in various fields. Therefore, the main instructional objectives for mathematics are as follows:

1. Knowledge with Specifications

The students

- 1.1 recall or reproduce terms, facts, etc.
- 1.2 recognise terms, symbols, concepts, etc.

2. Understanding with Specifications

The students

- 2.1 give illustrations for terms, definitions etc.
- 2.2 detect conceptual errors (and correct) in definitions, statements, formulae, etc.
- 2.3 compare concepts, quantities, etc.
- 2.4 discriminate between closely related concepts
- 2.5 translate verbal statements into mathematical statements and vice-versa
- 2.6 verify the results arrived at
- 2.7 classify data as per criteria
- 2.8 find relationships among the given data
- 2.9 interpret the data

3. Application with Specification

- 3.1 analyse and find out what is given and what is required to be done
- 3.2 find out the adequacy, superfluousness and relevancy of data
- 3.3 establish relationship among the data

- 3.4 reason out deductively
- 3.5 select appropriate methods for solutions problems
- 3.6 suggest alternative methods for solving problems
- 3.7 generalise from particular situations

4. Skill with Specifications

- 4.1 Carry out calculation easily and quickly
- 4.2 Handle geometrical instruments properly
- 4.3 Draw figure accurately and to the scale
- 4.4 Read tables and graphs properly
- 4.5 Interpret graphs correctly

As far as the main goal or objective in the NCF-2005 is concerned, it is to develop abilities in the student for mathematisation. It also states (1) the narrow aims of school mathematics, which concern with decimals and percents and (2) the higher aims, which are for developing the child resources to think and reason mathematically, to pursue assumption to their logical conclusions and to handle abstractions. Keeping this in view, at this stage, the stress is only on the higher aims. These higher aims may be considered as the instructional objectives. Objective based questions and objective type questions are often confused with each other. When a question is framed keeping a definite aim or objective in mind, it is called an objective based question, while if a question is framed to measure the students achievement which is objective rather than subjective is called objective type question. It may also be noted that determination of the objective of a question varies from person to person. For example, a question may appear to be of 'knowledge' type to one teacher who may think that the answer of the question is known to the students, but the same question may appear to be of understanding type to another teacher if she thinks that the question is completely unknown to the same group of students. In the light of the views expressed in NCF-2005, the following types of questions are suggested:

- 1. Long answer questions
- 2. Short answer questions
- 3. Short answer questions with reasoning
- 4. Multiple choice questions

It is hoped that these questions along with the questions in the textbook would be effectively able to evaluate the Classes IX and X students in mathematics.

CONTENTS

FOREWORD		iii
PREFACE		v
STUDENTS' EVALUATION IN MATHEMATICS AT SECONDARY STAGE		
CHAPTER 1	Number Systems	1
CHAPTER 2	Polynomials	13
CHAPTER 3	Coordinate Geometry	24
CHAPTER 4	Linear Equations in Two Variables	33
CHAPTER 5	Introduction to Euclid's Geometry	43
CHAPTER 6	Lines and Angles	54
CHAPTER 7	Triangles	63
CHAPTER 8	Quadrilaterals	72
CHAPTER 9	Areas of Parallelograms and Triangles	84
CHAPTER 10	Circles	97
CHAPTER 11	Constructions	108
CHAPTER 12	Heron's Formula	112
CHAPTER 13	Surface Areas and Volumes	121
CHAPTER 14	Statistics and Probability	129
Answers		150
	Design of the Question Paper , <i>Set-I</i>	169
	Design of the Question Paper, <i>Set-II</i>	184

THE CONSTITUTION OF INDIA

PREAMBLE

WE, THE PEOPLE OF INDIA, having solemnly resolved to constitute India into a **SOVEREIGN SOCIALIST SECULAR DEMOCRATIC REPUBLIC** and to secure to all its citizens :

JUSTICE, social, economic and political;

LIBERTY of thought, expression, belief, faith and worship;

EQUALITY of status and of opportunity; and to promote among them all

FRATERNITY assuring the dignity of the individual and the unity and integrity of the Nation;

IN OUR CONSTITUENT ASSEMBLY this twenty-sixth day of November, 1949, do **HEREBY ADOPT, ENACT AND GIVE TO OURSELVES THIS CONSTITUTION.**

NUMBER SYSTEMS

(A) Main Concepts and Results

Rational numbers

Irrational numbers

Locating irrational numbers on the number line

Real numbers and their decimal expansions

Representing real numbers on the number line

Operations on real numbers

Rationalisation of denominator

Laws of exponents for real numbers

- A number is called a rational number, if it can be written in the form $\frac{p}{q}$, where p and q are integers and $q \neq 0$.
- A number which cannot be expressed in the form $\frac{p}{q}$ (where p and q are integers and $q \neq 0$) is called an irrational number.
- All rational numbers and all irrational numbers together make the collection of real numbers.
- Decimal expansion of a rational number is either terminating or non-terminating recurring, while the decimal expansion of an irrational number is non-terminating non-recurring.

- If r is a rational number and s is an irrational number, then $r+s$ and $r-s$ are irrationals.
Further, if r is a non-zero rational, then rs and $\frac{r}{s}$ are irrationals.

- For positive real numbers a and b :

$$(i) \quad \sqrt{ab} = \sqrt{a}\sqrt{b}$$

$$(ii) \quad \sqrt{\frac{a}{b}} = \frac{\sqrt{a}}{\sqrt{b}}$$

$$(iii) \quad (\sqrt{a} + \sqrt{b})(\sqrt{a} - \sqrt{b}) = a - b$$

$$(iv) \quad (a + \sqrt{b})(a - \sqrt{b}) = a^2 - b$$

$$(v) \quad (\sqrt{a} + \sqrt{b})^2 = a + 2\sqrt{ab} + b$$

- If p and q are rational numbers and a is a positive real number, then

$$(i) \quad a^p \cdot a^q = a^{p+q}$$

$$(ii) \quad (a^p)^q = a^{pq}$$

$$(iii) \quad \frac{a^p}{a^q} = a^{p-q}$$

$$(iv) \quad a^p b^p = (ab)^p$$

(B) Multiple Choice Questions

Write the correct answer:

Sample Question 1 : Which of the following is not equal to $\left[\left(\frac{5}{6}\right)^{\frac{1}{5}}\right]^{\frac{1}{6}}$?

$$(A) \quad \left(\frac{5}{6}\right)^{\frac{1}{5} \cdot \frac{1}{6}} \quad (B) \quad \frac{1}{\left[\left(\frac{5}{6}\right)^{\frac{1}{5}}\right]^{\frac{1}{6}}} \quad (C) \quad \left(\frac{6}{5}\right)^{\frac{1}{30}} \quad (D) \quad \left(\frac{5}{6}\right)^{-\frac{1}{30}}$$

Solution : Answer (A)

EXERCISE 1.1

Write the correct answer in each of the following:

- Every rational number is

(A) a natural number	(B) an integer
(C) a real number	(D) a whole number

2. Between two rational numbers
- (A) there is no rational number
 - (B) there is exactly one rational number
 - (C) there are infinitely many rational numbers
 - (D) there are only rational numbers and no irrational numbers
3. Decimal representation of a rational number cannot be
- (A) terminating
 - (B) non-terminating
 - (C) non-terminating repeating
 - (D) non-terminating non-repeating
4. The product of any two irrational numbers is
- (A) always an irrational number
 - (B) always a rational number
 - (C) always an integer
 - (D) sometimes rational, sometimes irrational
5. The decimal expansion of the number $\sqrt{2}$ is
- (A) a finite decimal
 - (B) 1.41421
 - (C) non-terminating recurring
 - (D) non-terminating non-recurring
6. Which of the following is irrational?
- (A) $\sqrt{\frac{4}{9}}$ (B) $\frac{\sqrt{12}}{\sqrt{3}}$ (C) $\sqrt{7}$ (D) $\sqrt{81}$
7. Which of the following is irrational?
- (A) 0.14 (B) $0.14\overline{16}$ (C) $0.\overline{1416}$ (D) 0.4014001400014...
8. A rational number between $\sqrt{2}$ and $\sqrt{3}$ is
- (A) $\frac{\sqrt{2} + \sqrt{3}}{2}$ (B) $\frac{\sqrt{2} \cdot \sqrt{3}}{2}$ (C) 1.5 (D) 1.8

9. The value of $1.999\dots$ in the form $\frac{p}{q}$, where p and q are integers and $q \neq 0$, is

- (A) $\frac{19}{10}$ (B) $\frac{1999}{1000}$ (C) 2 (D) $\frac{1}{9}$

10. $2\sqrt{3} + \sqrt{3}$ is equal to

- (A) $2\sqrt{6}$ (B) 6 (C) $3\sqrt{3}$ (D) $4\sqrt{6}$

11. $\sqrt{10} \times \sqrt{15}$ is equal to

- (A) $6\sqrt{5}$ (B) $5\sqrt{6}$ (C) $\sqrt{25}$ (D) $10\sqrt{5}$

12. The number obtained on rationalising the denominator of $\frac{1}{\sqrt{7}-2}$ is

- (A) $\frac{\sqrt{7}+2}{3}$ (B) $\frac{\sqrt{7}-2}{3}$ (C) $\frac{\sqrt{7}+2}{5}$ (D) $\frac{\sqrt{7}+2}{45}$

13. $\frac{1}{\sqrt{9}-\sqrt{8}}$ is equal to

- (A) $\frac{1}{2}(3-2\sqrt{2})$ (B) $\frac{1}{3+2\sqrt{2}}$
(C) $3-2\sqrt{2}$ (D) $3+2\sqrt{2}$

14. After rationalising the denominator of $\frac{7}{3\sqrt{3}-2\sqrt{2}}$, we get the denominator as

- (A) 13 (B) 19 (C) 5 (D) 35

15. The value of $\frac{\sqrt{32} + \sqrt{48}}{\sqrt{8} + \sqrt{12}}$ is equal to

- (A) $\sqrt{2}$ (B) 2 (C) 4 (D) 8

16. If $\sqrt{2} = 1.4142$, then $\sqrt{\frac{\sqrt{2}-1}{\sqrt{2}+1}}$ is equal to

- (A) 2.4142 (B) 5.8282
(C) 0.4142 (D) 0.1718

17. $\sqrt[4]{\sqrt[3]{2^2}}$ equals

- (A) $2^{-\frac{1}{6}}$ (B) 2^{-6} (C) $2^{\frac{1}{6}}$ (D) 2^6

18. The product $\sqrt[3]{2} \cdot \sqrt[4]{2} \cdot \sqrt[12]{32}$ equals

- (A) $\sqrt{2}$ (B) 2 (C) $\sqrt[12]{2}$ (D) $\sqrt[12]{32}$

19. Value of $\sqrt[4]{(81)^{-2}}$ is

- (A) $\frac{1}{9}$ (B) $\frac{1}{3}$ (C) 9 (D) $\frac{1}{81}$

20. Value of $(256)^{0.16} \times (256)^{0.09}$ is

- (A) 4 (B) 16 (C) 64 (D) 256.25

21. Which of the following is equal to x ?

- (A) $x^{\frac{12}{7}} - x^{\frac{5}{7}}$ (B) $\sqrt[12]{(x^4)^{\frac{1}{3}}}$ (C) $(\sqrt{x^3})^{\frac{2}{3}}$ (D) $x^{\frac{12}{7}} \times x^{\frac{7}{12}}$

(C) Short Answer Questions with Reasoning

Sample Question 1: Are there two irrational numbers whose sum and product both are rationals? Justify.

Solution : Yes.

$3 + \sqrt{2}$ and $3 - \sqrt{2}$ are two irrational numbers.

$(3 + \sqrt{2}) + (3 - \sqrt{2}) = 6$, a rational number.

$(3 + \sqrt{2}) \times (3 - \sqrt{2}) = 7$, a rational number.

So, we have two irrational numbers whose sum and product both are rationals.

Sample Question 2: State whether the following statement is true:

There is a number x such that x^2 is irrational but x^4 is rational. Justify your answer by an example.

Solution : True.

Let us take $x = \sqrt[4]{2}$

Now, $x^2 = (\sqrt[4]{2})^2 = \sqrt{2}$, an irrational number.

$$x^4 = (\sqrt[4]{2})^4 = 2, \text{ a rational number.}$$

So, we have a number x such that x^2 is irrational but x^4 is rational.

EXERCISE 1.2

- Let x and y be rational and irrational numbers, respectively. Is $x + y$ necessarily an irrational number? Give an example in support of your answer.
- Let x be rational and y be irrational. Is xy necessarily irrational? Justify your answer by an example.
- State whether the following statements are true or false? Justify your answer.

(i) $\frac{\sqrt{2}}{3}$ is a rational number.

(ii) There are infinitely many integers between any two integers.

(iii) Number of rational numbers between 15 and 18 is finite.

(iv) There are numbers which cannot be written in the form $\frac{p}{q}$, $q \neq 0$, p, q both are integers.

(v) The square of an irrational number is always rational.

(vi) $\frac{\sqrt{12}}{\sqrt{3}}$ is not a rational number as $\sqrt{12}$ and $\sqrt{3}$ are not integers.

(vii) $\frac{\sqrt{15}}{\sqrt{3}}$ is written in the form $\frac{p}{q}$, $q \neq 0$ and so it is a rational number.

- Classify the following numbers as rational or irrational with justification :

(i) $\sqrt{196}$

(ii) $3\sqrt{18}$

(iii) $\sqrt{\frac{9}{27}}$

(iv) $\frac{\sqrt{28}}{\sqrt{343}}$

- (v) $-\sqrt{0.4}$ (vi) $\frac{\sqrt{12}}{\sqrt{75}}$ (vii) 0.5918
- (viii) $(1 + \sqrt{5}) - (4 + \sqrt{5})$ (ix) 10.124124... (x) 1.010010001...

(D) Short Answer Questions

Sample Question 1: Locate $\sqrt{13}$ on the number line.

Solution : We write 13 as the sum of the squares of two natural numbers :

$$13 = 9 + 4 = 3^2 + 2^2$$

On the number line, take $OA = 3$ units.

Draw $BA = 2$ units, perpendicular to OA . Join OB (see Fig.1.1).

By Pythagoras theorem,

$$OB = \sqrt{13}$$

Using a compass with centre O and radius OB , draw an arc which intersects the number line at the point C . Then, C corresponds to

$$\sqrt{13}.$$

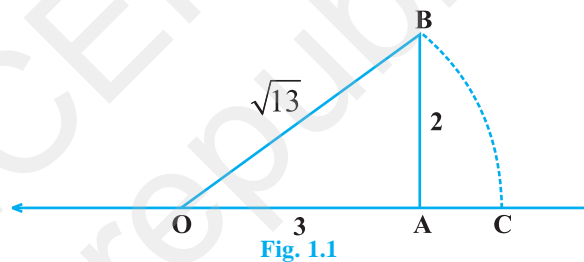

Fig. 1.1

Remark : We can also take $OA = 2$ units and $AB = 3$ units.

Sample Question 2 : Express $0.12\bar{3}$ in the form $\frac{p}{q}$, where p and q are integers and

$q \neq 0$.

Solution :

Let $x = 0.12\bar{3}$

so, $10x = 1.2\bar{3}$

or $10x - x = 1.2\bar{3} - 0.12\bar{3} = 1.2333 \dots - 0.12333 \dots$

or $9x = 1.11$

or $x = \frac{1.11}{9} = \frac{111}{900}$

Therefore, $0.12\bar{3} = \frac{111}{900} = \frac{37}{300}$

Sample Question 3 : Simplify : $(3\sqrt{5} - 5\sqrt{2})(4\sqrt{5} + 3\sqrt{2})$.

Solution : $(3\sqrt{5} - 5\sqrt{2})(4\sqrt{5} + 3\sqrt{2})$

$$= 12 \times 5 - 20\sqrt{2} \times \sqrt{5} + 9\sqrt{5} \times \sqrt{2} - 15 \times 2$$

$$= 60 - 20\sqrt{10} + 9\sqrt{10} - 30$$

$$= 30 - 11\sqrt{10}$$

Sample Question 4 : Find the value of a in the following :

$$\frac{6}{3\sqrt{2} - 2\sqrt{3}} = 3\sqrt{2} - a\sqrt{3}$$

Solution : $\frac{6}{3\sqrt{2} - 2\sqrt{3}} = \frac{6}{3\sqrt{2} - 2\sqrt{3}} \times \frac{3\sqrt{2} + 2\sqrt{3}}{3\sqrt{2} + 2\sqrt{3}}$

$$= \frac{6(3\sqrt{2} + 2\sqrt{3})}{(3\sqrt{2})^2 - (2\sqrt{3})^2} = \frac{6(3\sqrt{2} + 2\sqrt{3})}{18 - 12} = \frac{6(3\sqrt{2} + 2\sqrt{3})}{6}$$

$$= 3\sqrt{2} + 2\sqrt{3}$$

Therefore, $3\sqrt{2} + 2\sqrt{3} = 3\sqrt{2} - a\sqrt{3}$

or $a = -2$

Sample Question 5 : Simplify : $\left[5\left(\frac{1}{8^3} + 27\frac{1}{3}\right)^3\right]^{\frac{1}{4}}$

Solution :

$$\left[5\left(\frac{1}{8^3} + 27\frac{1}{3}\right)^3\right]^{\frac{1}{4}} = \left[5\left((2^3)^{\frac{1}{3}} + (3^3)^{\frac{1}{3}}\right)^3\right]^{\frac{1}{4}}$$

$$\begin{aligned}
 &= [5(2+3)^3]^{\frac{1}{4}} \\
 &= [5(5)^3]^{\frac{1}{4}} \\
 &= [5^4]^{\frac{1}{4}} = 5
 \end{aligned}$$

EXERCISE 1.3

1. Find which of the variables x , y , z and u represent rational numbers and which irrational numbers:

(i) $x^2 = 5$ (ii) $y^2 = 9$ (iii) $z^2 = .04$ (iv) $u^2 = \frac{17}{4}$

2. Find three rational numbers between

(i) -1 and -2 (ii) 0.1 and 0.11
 (iii) $\frac{5}{7}$ and $\frac{6}{7}$ (iv) $\frac{1}{4}$ and $\frac{1}{5}$

3. Insert a rational number and an irrational number between the following :

(i) 2 and 3 (ii) 0 and 0.1 (iii) $\frac{1}{3}$ and $\frac{1}{2}$
 (iv) $\frac{-2}{5}$ and $\frac{1}{2}$ (v) 0.15 and 0.16 (vi) $\sqrt{2}$ and $\sqrt{3}$
 (vii) 2.357 and 3.121 (viii) $.0001$ and $.001$ (ix) 3.623623 and 0.484848
 (x) 6.375289 and 6.375738

4. Represent the following numbers on the number line :

$$7, 7.2, \frac{-3}{2}, \frac{-12}{5}$$

5. Locate $\sqrt{5}$, $\sqrt{10}$ and $\sqrt{17}$ on the number line.

6. Represent geometrically the following numbers on the number line :

(i) $\sqrt{4.5}$ (ii) $\sqrt{5.6}$ (iii) $\sqrt{8.1}$ (iv) $\sqrt{2.3}$

7. Express the following in the form $\frac{p}{q}$, where p and q are integers and $q \neq 0$:

- (i) 0.2 (ii) 0.888... (iii) $5\bar{2}$ (iv) $0.\overline{001}$
 (v) 0.2555... (vi) $0.1\overline{34}$ (vii) .00323232... (viii) .404040...

8. Show that $0.142857142857... = \frac{1}{7}$

9. Simplify the following:

- (i) $\sqrt{45} - 3\sqrt{20} + 4\sqrt{5}$ (ii) $\frac{\sqrt{24}}{8} + \frac{\sqrt{54}}{9}$
 (iii) $\sqrt[4]{12} \times \sqrt[3]{6}$ (iv) $4\sqrt[4]{28} \div 3\sqrt[3]{7} \div \sqrt[3]{7}$
 (v) $3\sqrt{3} + 2\sqrt{27} + \frac{7}{\sqrt{3}}$ (vi) $(\sqrt{3} - \sqrt{2})^2$
 (vii) $\sqrt[4]{81} - 8\sqrt[3]{216} + 15\sqrt[5]{32} + \sqrt{225}$ (viii) $\frac{3}{\sqrt{8}} + \frac{1}{\sqrt{2}}$
 (ix) $\frac{2\sqrt{3}}{3} - \frac{\sqrt{3}}{6}$

10. Rationalise the denominator of the following:

- (i) $\frac{2}{3\sqrt{3}}$ (ii) $\frac{\sqrt{40}}{\sqrt{3}}$ (iii) $\frac{3 + \sqrt{2}}{4\sqrt{2}}$
 (iv) $\frac{16}{\sqrt{41} - 5}$ (v) $\frac{2 + \sqrt{3}}{2 - \sqrt{3}}$ (vi) $\frac{\sqrt{6}}{\sqrt{2} + \sqrt{3}}$
 (vii) $\frac{\sqrt{3} + \sqrt{2}}{\sqrt{3} - \sqrt{2}}$ (viii) $\frac{3\sqrt{5} + \sqrt{3}}{\sqrt{5} - \sqrt{3}}$ (ix) $\frac{4\sqrt{3} + 5\sqrt{2}}{\sqrt{48} + \sqrt{18}}$

11. Find the values of a and b in each of the following:

- (i) $\frac{5 + 2\sqrt{3}}{7 + 4\sqrt{3}} = a - 6\sqrt{3}$

$$(ii) \frac{3 - \sqrt{5}}{3 + 2\sqrt{5}} = a\sqrt{5} - \frac{19}{11}$$

$$(iii) \frac{\sqrt{2} + \sqrt{3}}{3\sqrt{2} - 2\sqrt{3}} = 2 - b\sqrt{6}$$

$$(iv) \frac{7 + \sqrt{5}}{7 - \sqrt{5}} - \frac{7 - \sqrt{5}}{7 + \sqrt{5}} = a + \frac{7}{11}\sqrt{5}b$$

12. If $a = 2 + \sqrt{3}$, then find the value of $a - \frac{1}{a}$.

13. Rationalise the denominator in each of the following and hence evaluate by taking $\sqrt{2} = 1.414$, $\sqrt{3} = 1.732$ and $\sqrt{5} = 2.236$, upto three places of decimal.

$$(i) \frac{4}{\sqrt{3}} \quad (ii) \frac{6}{\sqrt{6}} \quad (iii) \frac{\sqrt{10} - \sqrt{5}}{2}$$

$$(iv) \frac{\sqrt{2}}{2 + \sqrt{2}} \quad (v) \frac{1}{\sqrt{3} + \sqrt{2}}$$

14. Simplify:

$$(i) (1^3 + 2^3 + 3^3)^{\frac{1}{2}} \quad (ii) \left(\frac{3}{5}\right)^4 \left(\frac{8}{5}\right)^{-12} \left(\frac{32}{5}\right)^6$$

$$(iii) \left(\frac{1}{27}\right)^{-\frac{2}{3}} \quad (iv) \left[\left((625)^{-\frac{1}{2}} \right)^{-\frac{1}{4}} \right]^2$$

$$(v) \frac{9^{\frac{1}{3}} \times 27^{-\frac{1}{2}}}{3^{\frac{1}{6}} \times 3^{-\frac{2}{3}}} \quad (vi) 64^{-\frac{1}{3}} \left[64^{\frac{1}{3}} - 64^{\frac{2}{3}} \right]$$

$$(vii) \frac{8^{\frac{1}{3}} \times 16^{\frac{1}{3}}}{32^{-\frac{1}{3}}}$$

(E) Long Answer Questions

Sample Question 1 : If $a = 5 + 2\sqrt{6}$ and $b = \frac{1}{a}$, then what will be the value of $a^2 + b^2$?

Solution : $a = 5 + 2\sqrt{6}$

$$b = \frac{1}{a} = \frac{1}{5 + 2\sqrt{6}} = \frac{1}{5 + 2\sqrt{6}} \times \frac{5 - 2\sqrt{6}}{5 - 2\sqrt{6}} = \frac{5 - 2\sqrt{6}}{5^2 - (2\sqrt{6})^2} = \frac{5 - 2\sqrt{6}}{25 - 24} = 5 - 2\sqrt{6}$$

Therefore, $a^2 + b^2 = (a + b)^2 - 2ab$

Here, $a + b = (5 + 2\sqrt{6}) + (5 - 2\sqrt{6}) = 10$

$$ab = (5 + 2\sqrt{6})(5 - 2\sqrt{6}) = 5^2 - (2\sqrt{6})^2 = 25 - 24 = 1$$

Therefore, $a^2 + b^2 = 10^2 - 2 \times 1 = 100 - 2 = 98$

EXERCISE 1.4

1. Express $0.6 + 0.\bar{7} + 0.4\bar{7}$ in the form $\frac{p}{q}$, where p and q are integers and $q \neq 0$.

2. Simplify: $\frac{7\sqrt{3}}{\sqrt{10} + \sqrt{3}} - \frac{2\sqrt{5}}{\sqrt{6} + \sqrt{5}} - \frac{3\sqrt{2}}{\sqrt{15} + 3\sqrt{2}}$.

3. If $\sqrt{2} = 1.414$, $\sqrt{3} = 1.732$, then find the value of $\frac{4}{3\sqrt{3} - 2\sqrt{2}} + \frac{3}{3\sqrt{3} + 2\sqrt{2}}$.

4. If $a = \frac{3 + \sqrt{5}}{2}$, then find the value of $a^2 + \frac{1}{a^2}$.

5. If $x = \frac{\sqrt{3} + \sqrt{2}}{\sqrt{3} - \sqrt{2}}$ and $y = \frac{\sqrt{3} - \sqrt{2}}{\sqrt{3} + \sqrt{2}}$, then find the value of $x^2 + y^2$.

6. Simplify: $(256)^{-\left(\frac{3}{4}\right)}$

7. Find the value of $\frac{4}{(216)^{-\frac{2}{3}}} + \frac{1}{(256)^{-\frac{3}{4}}} + \frac{2}{(243)^{-\frac{1}{5}}}$

POLYNOMIALS

(A) Main Concepts and Results

Meaning of a Polynomial

Degree of a polynomial

Coefficients

Monomials, Binomials etc.

Constant, Linear, Quadratic Polynomials etc.

Value of a polynomial for a given value of the variable

Zeros of a polynomial

Remainder theorem

Factor theorem

Factorisation of a quadratic polynomial by splitting the middle term

Factorisation of algebraic expressions by using the Factor theorem

Algebraic identities –

$$(x + y)^2 = x^2 + 2xy + y^2$$

$$(x - y)^2 = x^2 - 2xy + y^2$$

$$x^2 - y^2 = (x + y)(x - y)$$

$$(x + a)(x + b) = x^2 + (a + b)x + ab$$

$$(x + y + z)^2 = x^2 + y^2 + z^2 + 2xy + 2yz + 2zx$$

$$(x + y)^3 = x^3 + 3x^2y + 3xy^2 + y^3 = x^3 + y^3 + 3xy(x + y)$$

$$(x - y)^3 = x^3 - 3x^2y + 3xy^2 - y^3 = x^3 - y^3 - 3xy(x - y)$$

$$x^3 + y^3 = (x + y)(x^2 - xy + y^2)$$

$$x^3 - y^3 = (x - y)(x^2 + xy + y^2)$$

$$x^3 + y^3 + z^3 - 3xyz = (x + y + z)(x^2 + y^2 + z^2 - xy - yz - zx)$$

(B) Multiple Choice Questions

Sample Question 1 : If $x^2 + kx + 6 = (x + 2)(x + 3)$ for all x , then the value of k is

- (A) 1 (B) -1 (C) 5 (D) 3

Solution : Answer (C)

EXERCISE 2.1

Write the correct answer in each of the following :

1. Which one of the following is a polynomial?

(A) $\frac{x^2}{2} - \frac{2}{x^2}$

(B) $\sqrt{2x} - 1$

(C) $x^2 + \frac{3x^{\frac{3}{2}}}{\sqrt{x}}$

(D) $\frac{x-1}{x+1}$

2. $\sqrt{2}$ is a polynomial of degree

- (A) 2 (B) 0 (C) 1 (D) $\frac{1}{2}$

3. Degree of the polynomial $4x^4 + 0x^3 + 0x^5 + 5x + 7$ is

- (A) 4 (B) 5 (C) 3 (D) 7

4. Degree of the zero polynomial is

- (A) 0 (B) 1 (C) Any natural number
(D) Not defined

5. If $p(x) = x^2 - 2\sqrt{2}x + 1$, then $p(2\sqrt{2})$ is equal to

- (A) 0 (B) 1 (C) $4\sqrt{2}$ (D) $8\sqrt{2} + 1$

6. The value of the polynomial $5x - 4x^2 + 3$, when $x = -1$ is

- (A) -6 (B) 6 (C) 2 (D) -2

7. If $p(x) = x + 3$, then $p(x) + p(-x)$ is equal to
(A) 3 (B) $2x$ (C) 0 (D) 6
8. Zero of the zero polynomial is
(A) 0 (B) 1
(C) Any real number (D) Not defined
9. Zero of the polynomial $p(x) = 2x + 5$ is
(A) $-\frac{2}{5}$ (B) $-\frac{5}{2}$ (C) $\frac{2}{5}$ (D) $\frac{5}{2}$
10. One of the zeroes of the polynomial $2x^2 + 7x - 4$ is
(A) 2 (B) $\frac{1}{2}$ (C) $-\frac{1}{2}$ (D) -2
11. If $x^{51} + 51$ is divided by $x + 1$, the remainder is
(A) 0 (B) 1 (C) 49 (D) 50
12. If $x + 1$ is a factor of the polynomial $2x^2 + kx$, then the value of k is
(A) -3 (B) 4 (C) 2 (D) -2
13. $x + 1$ is a factor of the polynomial
(A) $x^3 + x^2 - x + 1$ (B) $x^3 + x^2 + x + 1$
(C) $x^4 + x^3 + x^2 + 1$ (D) $x^4 + 3x^3 + 3x^2 + x + 1$
14. One of the factors of $(25x^2 - 1) + (1 + 5x)^2$ is
(A) $5 + x$ (B) $5 - x$ (C) $5x - 1$ (D) $10x$
15. The value of $249^2 - 248^2$ is
(A) 1^2 (B) 477 (C) 487 (D) 497
16. The factorisation of $4x^2 + 8x + 3$ is
(A) $(x + 1)(x + 3)$ (B) $(2x + 1)(2x + 3)$
(C) $(2x + 2)(2x + 5)$ (D) $(2x - 1)(2x - 3)$
17. Which of the following is a factor of $(x + y)^3 - (x^3 + y^3)$?
(A) $x^2 + y^2 + 2xy$ (B) $x^2 + y^2 - xy$ (C) xy^2 (D) $3xy$
18. The coefficient of x in the expansion of $(x + 3)^3$ is
(A) 1 (B) 9 (C) 18 (D) 27
19. If $\frac{x}{y} + \frac{y}{x} = -1$ ($x, y \neq 0$), the value of $x^3 - y^3$ is

- (A) 1 (B) -1 (C) 0 (D) $\frac{1}{2}$

20. If $49x^2 - b = \left(7x + \frac{1}{2}\right)\left(7x - \frac{1}{2}\right)$, then the value of b is

- (A) 0 (B) $\frac{1}{\sqrt{2}}$ (C) $\frac{1}{4}$ (D) $\frac{1}{2}$

21. If $a + b + c = 0$, then $a^3 + b^3 + c^3$ is equal to

- (A) 0 (B) abc (C) $3abc$ (D) $2abc$

(C) Short Answer Questions with Reasoning

Sample Question 1 : Write whether the following statements are **True** or **False**. Justify your answer.

- (i) $\frac{1}{\sqrt{5}}x^{\frac{1}{2}} + 1$ is a polynomial (ii) $\frac{6\sqrt{x} + x^{\frac{3}{2}}}{\sqrt{x}}$ is a polynomial, $x \neq 0$

Solution :

- (i) False, because the exponent of the variable is not a whole number.
- (ii) True, because $\frac{6\sqrt{x} + x^{\frac{3}{2}}}{\sqrt{x}} = 6 + x$, which is a polynomial.

EXERCISE 2.2

1. Which of the following expressions are polynomials? Justify your answer:

- (i) 8 (ii) $\sqrt{3}x^2 - 2x$ (iii) $1 - \sqrt{5}x$
- (iv) $\frac{1}{5x^{-2}} + 5x + 7$ (v) $\frac{(x-2)(x-4)}{x}$ (vi) $\frac{1}{x+1}$
- (vii) $\frac{1}{7}a^3 - \frac{2}{\sqrt{3}}a^2 + 4a - 7$ (viii) $\frac{1}{2x}$

2. Write whether the following statements are **True** or **False**. Justify your answer.

- (i) A binomial can have at most two terms
- (ii) Every polynomial is a binomial
- (iii) A binomial may have degree 5
- (iv) Zero of a polynomial is always 0
- (v) A polynomial cannot have more than one zero
- (vi) The degree of the sum of two polynomials each of degree 5 is always 5.

(D) Short Answer Questions

Sample Question 1 :

- (i) Check whether $p(x)$ is a multiple of $g(x)$ or not, where
 $p(x) = x^3 - x + 1$, $g(x) = 2 - 3x$
- (ii) Check whether $g(x)$ is a factor of $p(x)$ or not, where

$$p(x) = 8x^3 - 6x^2 - 4x + 3, \quad g(x) = \frac{x}{3} - \frac{1}{4}$$

Solution :

- (i) $p(x)$ will be a multiple of $g(x)$ if $g(x)$ divides $p(x)$.

$$\text{Now, } g(x) = 2 - 3x = 0 \text{ gives } x = \frac{2}{3}$$

$$\text{Remainder} = p\left(\frac{2}{3}\right) = \left(\frac{2}{3}\right)^3 - \left(\frac{2}{3}\right) + 1$$

$$= \frac{8}{27} - \frac{2}{3} + 1 = \frac{17}{27}$$

Since remainder $\neq 0$, so, $p(x)$ is not a multiple of $g(x)$.

- (ii) $g(x) = \frac{x}{3} - \frac{1}{4} = 0$ gives $x = \frac{3}{4}$

$g(x)$ will be a factor of $p(x)$ if $p\left(\frac{3}{4}\right) = 0$ (Factor theorem)

$$\text{Now, } p\left(\frac{3}{4}\right) = 8\left(\frac{3}{4}\right)^3 - 6\left(\frac{3}{4}\right)^2 - 4\left(\frac{3}{4}\right) + 3$$

$$= 8 \times \frac{27}{64} - 6 \times \frac{9}{16} - 3 + 3 = 0$$

Since, $p\left(\frac{3}{4}\right) = 0$, so, $g(x)$ is a factor of $p(x)$.

Sample Question 2 : Find the value of a , if $x - a$ is a factor of $x^3 - ax^2 + 2x + a - 1$.

Solution : Let $p(x) = x^3 - ax^2 + 2x + a - 1$

Since $x - a$ is a factor of $p(x)$, so $p(a) = 0$.

$$\text{i.e., } a^3 - a(a)^2 + 2a + a - 1 = 0$$

$$a^3 - a^3 + 2a + a - 1 = 0$$

$$3a = 1$$

Therefore, $a = \frac{1}{3}$

Sample Question 3 : (i) Without actually calculating the cubes, find the value of $48^3 - 30^3 - 18^3$.

(ii) Without finding the cubes, factorise $(x - y)^3 + (y - z)^3 + (z - x)^3$.

Solution : We know that $x^3 + y^3 + z^3 - 3xyz = (x + y + z)(x^2 + y^2 + z^2 - xy - yz - zx)$.

If $x + y + z = 0$, then $x^3 + y^3 + z^3 - 3xyz = 0$ or $x^3 + y^3 + z^3 = 3xyz$.

(i) We have to find the value of $48^3 - 30^3 - 18^3 = 48^3 + (-30)^3 + (-18)^3$.

$$\text{Here, } 48 + (-30) + (-18) = 0$$

$$\text{So, } 48^3 + (-30)^3 + (-18)^3 = 3 \times 48 \times (-30) \times (-18) = 77760$$

(ii) Here, $(x - y) + (y - z) + (z - x) = 0$

$$\text{Therefore, } (x - y)^3 + (y - z)^3 + (z - x)^3 = 3(x - y)(y - z)(z - x).$$

EXERCISE 2.3

1. Classify the following polynomials as polynomials in one variable, two variables etc.

(i) $x^2 + x + 1$

(ii) $y^3 - 5y$

(iii) $xy + yz + zx$

(iv) $x^2 - 2xy + y^2 + 1$

2. Determine the degree of each of the following polynomials :

(i) $2x - 1$

(ii) -10

(iii) $x^3 - 9x + 3x^5$

(iv) $y^3(1 - y^4)$

3. For the polynomial

$$\frac{x^3 + 2x + 1}{5} - \frac{7}{2}x^2 - x^6, \text{ write}$$

(i) the degree of the polynomial

(ii) the coefficient of x^3 (iii) the coefficient of x^6

(iv) the constant term

4. Write the coefficient of x^2 in each of the following :

(i) $\frac{\pi}{6}x + x^2 - 1$

(ii) $3x - 5$

(iii) $(x - 1)(3x - 4)$

(iv) $(2x - 5)(2x^2 - 3x + 1)$

5. Classify the following as a constant, linear, quadratic and cubic polynomials :

(i) $2 - x^2 + x^3$

(ii) $3x^3$

(iii) $5t - \sqrt{7}$

(iv) $4 - 5y^2$

(v) 3

(vi) $2 + x$

(vii) $y^3 - y$

(viii) $1 + x + x^2$

(ix) t^2

(x) $\sqrt{2}x - 1$

6. Give an example of a polynomial, which is :

(i) monomial of degree 1

(ii) binomial of degree 20

(iii) trinomial of degree 2

7. Find the value of the polynomial $3x^3 - 4x^2 + 7x - 5$, when $x = 3$ and also when $x = -3$.

8. If $p(x) = x^2 - 4x + 3$, evaluate : $p(2) - p(-1) + p\left(\frac{1}{2}\right)$

9. Find $p(0), p(1), p(-2)$ for the following polynomials :

(i) $p(x) = 10x - 4x^2 - 3$

(ii) $p(y) = (y + 2)(y - 2)$

10. Verify whether the following are **True** or **False** :

(i) -3 is a zero of $x - 3$

(ii) $-\frac{1}{3}$ is a zero of $3x + 1$

(iii) $\frac{-4}{5}$ is a zero of $4 - 5y$

(iv) 0 and 2 are the zeroes of $t^2 - 2t$

(v) -3 is a zero of $y^2 + y - 6$

11. Find the zeroes of the polynomial in each of the following :

(i) $p(x) = x - 4$

(ii) $g(x) = 3 - 6x$

(iii) $q(x) = 2x - 7$

(iv) $h(y) = 2y$

12. Find the zeroes of the polynomial :

$$p(x) = (x - 2)^2 - (x + 2)^2$$

13. By actual division, find the quotient and the remainder when the first polynomial is divided by the second polynomial : $x^4 + 1$; $x - 1$

14. By Remainder Theorem find the remainder, when $p(x)$ is divided by $g(x)$, where

(i) $p(x) = x^3 - 2x^2 - 4x - 1$, $g(x) = x + 1$

(ii) $p(x) = x^3 - 3x^2 + 4x + 50$, $g(x) = x - 3$

(iii) $p(x) = 4x^3 - 12x^2 + 14x - 3$, $g(x) = 2x - 1$

(iv) $p(x) = x^3 - 6x^2 + 2x - 4$, $g(x) = 1 - \frac{3}{2}x$

15. Check whether $p(x)$ is a multiple of $g(x)$ or not :

(i) $p(x) = x^3 - 5x^2 + 4x - 3$, $g(x) = x - 2$

(ii) $p(x) = 2x^3 - 11x^2 - 4x + 5$, $g(x) = 2x + 1$

16. Show that :

(i) $x + 3$ is a factor of $69 + 11x - x^2 + x^3$.

(ii) $2x - 3$ is a factor of $x + 2x^3 - 9x^2 + 12$.

17. Determine which of the following polynomials has $x - 2$ a factor :

(i) $3x^2 + 6x - 24$

(ii) $4x^2 + x - 2$

18. Show that $p - 1$ is a factor of $p^{10} - 1$ and also of $p^{11} - 1$.

19. For what value of m is $x^3 - 2mx^2 + 16$ divisible by $x + 2$?

20. If $x + 2a$ is a factor of $x^5 - 4a^2x^3 + 2x + 2a + 3$, find a .

21. Find the value of m so that $2x - 1$ be a factor of $8x^4 + 4x^3 - 16x^2 + 10x + m$.

22. If $x + 1$ is a factor of $ax^3 + x^2 - 2x + 4a - 9$, find the value of a .

23. Factorise :

(i) $x^2 + 9x + 18$

(ii) $6x^2 + 7x - 3$

(iii) $2x^2 - 7x - 15$

(iv) $84 - 2r - 2r^2$

24. Factorise :

(i) $2x^3 - 3x^2 - 17x + 30$

(ii) $x^3 - 6x^2 + 11x - 6$

(iii) $x^3 + x^2 - 4x - 4$

(iv) $3x^3 - x^2 - 3x + 1$

25. Using suitable identity, evaluate the following:

(i) 103^3

(ii) 101×102

(iii) 999^2

26. Factorise the following:

(i) $4x^2 + 20x + 25$

(ii) $9y^2 - 66yz + 121z^2$

(iii) $\left(2x + \frac{1}{3}\right)^2 - \left(x - \frac{1}{2}\right)^2$

27. Factorise the following :

(i) $9x^2 - 12x + 3$

(ii) $9x^2 - 12x + 4$

28. Expand the following :

(i) $(4a - b + 2c)^2$

(ii) $(3a - 5b - c)^2$

(iii) $(-x + 2y - 3z)^2$

29. Factorise the following :

(i) $9x^2 + 4y^2 + 16z^2 + 12xy - 16yz - 24xz$

(ii) $25x^2 + 16y^2 + 4z^2 - 40xy + 16yz - 20xz$

(iii) $16x^2 + 4y^2 + 9z^2 - 16xy - 12yz + 24xz$

30. If $a + b + c = 9$ and $ab + bc + ca = 26$, find $a^2 + b^2 + c^2$.

31. Expand the following :

(i) $(3a - 2b)^3$

(ii) $\left(\frac{1}{x} + \frac{y}{3}\right)^3$

(iii) $\left(4 - \frac{1}{3x}\right)^3$

32. Factorise the following :

(i) $1 - 64a^3 - 12a + 48a^2$

$$(ii) \quad 8p^3 + \frac{12}{5}p^2 + \frac{6}{25}p + \frac{1}{125}$$

33. Find the following products :

$$(i) \quad \left(\frac{x}{2} + 2y\right)\left(\frac{x^2}{4} - xy + 4y^2\right) \quad (ii) \quad (x^2 - 1)(x^4 + x^2 + 1)$$

34. Factorise :

$$(i) \quad 1 + 64x^3 \quad (ii) \quad a^3 - 2\sqrt{2}b^3$$

35. Find the following product :

$$(2x - y + 3z)(4x^2 + y^2 + 9z^2 + 2xy + 3yz - 6xz)$$

36. Factorise :

$$(i) \quad a^3 - 8b^3 - 64c^3 - 24abc \quad (ii) \quad 2\sqrt{2}a^3 + 8b^3 - 27c^3 + 18\sqrt{2}abc$$

37. Without actually calculating the cubes, find the value of :

$$(i) \quad \left(\frac{1}{2}\right)^3 + \left(\frac{1}{3}\right)^3 - \left(\frac{5}{6}\right)^3 \quad (ii) \quad (0.2)^3 - (0.3)^3 + (0.1)^3$$

38. Without finding the cubes, factorise

$$(x - 2y)^3 + (2y - 3z)^3 + (3z - x)^3$$

39. Find the value of

$$(i) \quad x^3 + y^3 - 12xy + 64, \text{ when } x + y = -4$$

$$(ii) \quad x^3 - 8y^3 - 36xy - 216, \text{ when } x = 2y + 6$$

40. Give possible expressions for the length and breadth of the rectangle whose area is given by $4a^2 + 4a - 3$.

(E) Long Answer Questions

Sample Question 1 : If $x + y = 12$ and $xy = 27$, find the value of $x^3 + y^3$.

Solution :

$$\begin{aligned} x^3 + y^3 &= (x + y)(x^2 - xy + y^2) \\ &= (x + y)[(x + y)^2 - 3xy] \\ &= 12[12^2 - 3 \times 27] \\ &= 12 \times 63 = 756 \end{aligned}$$

Alternative Solution :

$$\begin{aligned}
 x^3 + y^3 &= (x + y)^3 - 3xy(x + y) \\
 &= 12^3 - 3 \times 27 \times 12 \\
 &= 12 [12^2 - 3 \times 27] \\
 &= 12 \times 63 = 756
 \end{aligned}$$

EXERCISE 2.4

1. If the polynomials $az^3 + 4z^2 + 3z - 4$ and $z^3 - 4z + a$ leave the same remainder when divided by $z - 3$, find the value of a .
2. The polynomial $p(x) = x^4 - 2x^3 + 3x^2 - ax + 3a - 7$ when divided by $x + 1$ leaves the remainder 19. Find the values of a . Also find the remainder when $p(x)$ is divided by $x + 2$.
3. If both $x - 2$ and $x - \frac{1}{2}$ are factors of $px^2 + 5x + r$, show that $p = r$.
4. Without actual division, prove that $2x^4 - 5x^3 + 2x^2 - x + 2$ is divisible by $x^2 - 3x + 2$.
[Hint: Factorise $x^2 - 3x + 2$]
5. Simplify $(2x - 5y)^3 - (2x + 5y)^3$.
6. Multiply $x^2 + 4y^2 + z^2 + 2xy + xz - 2yz$ by $(-z + x - 2y)$.
7. If a, b, c are all non-zero and $a + b + c = 0$, prove that $\frac{a^2}{bc} + \frac{b^2}{ca} + \frac{c^2}{ab} = 3$.
8. If $a + b + c = 5$ and $ab + bc + ca = 10$, then prove that $a^3 + b^3 + c^3 - 3abc = -25$.
9. Prove that $(a + b + c)^3 - a^3 - b^3 - c^3 = 3(a + b)(b + c)(c + a)$.

COORDINATE GEOMETRY

(A) Main Concepts and Results

Cartesian system

Coordinate axes

Origin

Quadrants

Abscissa

Ordinate

Coordinates of a point

Ordered pair

Plotting of points in the cartesian plane:

- In the Cartesian plane, the horizontal line is called the x -axis and the vertical line is called the y -axis,
- The coordinate axes divide the plane into four parts called quadrants,
- The point of intersection of the axes is called the origin,
- Abscissa or the x -coordinate of a point is its distance from the y -axis and the ordinate or the y -coordinate is its distance from the x -axis,
- (x, y) are called the coordinates of the point whose abscissa is x and the ordinate is y ,
- Coordinates of a point on the x -axis are of the form $(x, 0)$ and that of the point on the y -axis is of the form $(0, y)$,

- The coordinates of the origin are $(0, 0)$,
- Signs of the coordinates of a point in the first quadrant are $(+, +)$, in the second quadrant $(-, +)$, in the third quadrant $(-, -)$ and in the fourth quadrant $(+, -)$.

(B) Multiple Choice Questions

Write the correct answer :

Sample Question 1: The points (other than origin) for which abscissa is equal to the ordinate will lie in

- (A) I quadrant only (B) I and II quadrants
(C) I and III quadrants (D) II and IV quadrants

Solution : Answer (C)

EXERCISE 3.1

Write the correct answer in each of the following :

1. Point $(-3, 5)$ lies in the
(A) first quadrant (B) second quadrant
(C) third quadrant (D) fourth quadrant
2. Signs of the abscissa and ordinate of a point in the second quadrant are respectively
(A) $+, +$ (B) $-, -$ (C) $-, +$ (D) $+, -$
3. Point $(0, -7)$ lies
(A) on the x -axis (B) in the second quadrant
(C) on the y -axis (D) in the fourth quadrant
4. Point $(-10, 0)$ lies
(A) on the negative direction of the x -axis
(B) on the negative direction of the y -axis
(C) in the third quadrant
(D) in the fourth quadrant
5. Abscissa of all the points on the x -axis is
(A) 0 (B) 1
(C) 2 (D) any number
6. Ordinate of all points on the x -axis is
(A) 0 (B) 1
(C) -1 (D) any number

7. The point at which the two coordinate axes meet is called the
(A) abscissa (B) ordinate (C) origin (D) quadrant
8. A point both of whose coordinates are negative will lie in
(A) I quadrant (B) II quadrant
(C) III quadrant (D) IV quadrant
9. Points $(1, -1)$, $(2, -2)$, $(4, -5)$, $(-3, -4)$
(A) lie in II quadrant (B) lie in III quadrant
(C) lie in IV quadrant (D) do not lie in the same quadrant
10. If y coordinate of a point is zero, then this point always lies
(A) in I quadrant (B) in II quadrant
(C) on x - axis (D) on y - axis
11. The points $(-5, 2)$ and $(2, -5)$ lie in the
(A) same quadrant (B) II and III quadrants, respectively
(C) II and IV quadrants, respectively (D) IV and II quadrants, respectively
12. If the perpendicular distance of a point P from the x -axis is 5 units and the foot of the perpendicular lies on the negative direction of x -axis, then the point P has
(A) x coordinate = -5 (B) y coordinate = 5 only
(C) y coordinate = -5 only (D) y coordinate = 5 or -5
13. On plotting the points O $(0, 0)$, A $(3, 0)$, B $(3, 4)$, C $(0, 4)$ and joining OA, AB, BC and CO which of the following figure is obtained?
(A) Square (B) Rectangle (C) Trapezium (D) Rhombus
14. If P $(-1, 1)$, Q $(3, -4)$, R $(1, -1)$, S $(-2, -3)$ and T $(-4, 4)$ are plotted on the graph paper, then the point(s) in the fourth quadrant are
(A) P and T (B) Q and R (C) Only S (D) P and R
15. If the coordinates of the two points are P $(-2, 3)$ and Q $(-3, 5)$, then (abscissa of P) $-$ (abscissa of Q) is
(A) -5 (B) 1 (C) -1 (D) -2
16. If P $(5, 1)$, Q $(8, 0)$, R $(0, 4)$, S $(0, 5)$ and O $(0, 0)$ are plotted on the graph paper, then the point(s) on the x -axis are
(A) P and R (B) R and S (C) Only Q (D) Q and O
17. Abscissa of a point is positive in
(A) I and II quadrants (B) I and IV quadrants
(C) I quadrant only (D) II quadrant only

18. The points whose abscissa and ordinate have different signs will lie in

- (A) I and II quadrants
- (B) II and III quadrants
- (C) I and III quadrants
- (D) II and IV quadrants

19. In Fig. 3.1, coordinates of P are

- (A) $(-4, 2)$ (B) $(-2, 4)$
- (C) $(4, -2)$ (D) $(2, -4)$

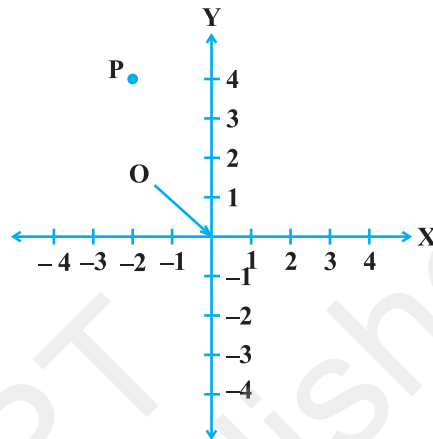

Fig. 3.1

20. In Fig. 3.2, the point identified by the coordinates $(-5, 3)$ is

- (A) T (B) R
- (C) L (D) S

21. The point whose ordinate is 4 and which lies on y-axis is

- (A) $(4, 0)$ (B) $(0, 4)$
- (C) $(1, 4)$ (D) $(4, 2)$

22. Which of the points $P(0, 3)$, $Q(1, 0)$, $R(0, -1)$, $S(-5, 0)$, $T(1, 2)$ do not lie on the x-axis?

- (A) P and R only
- (B) Q and S only
- (C) P, R and T
- (D) Q, S and T

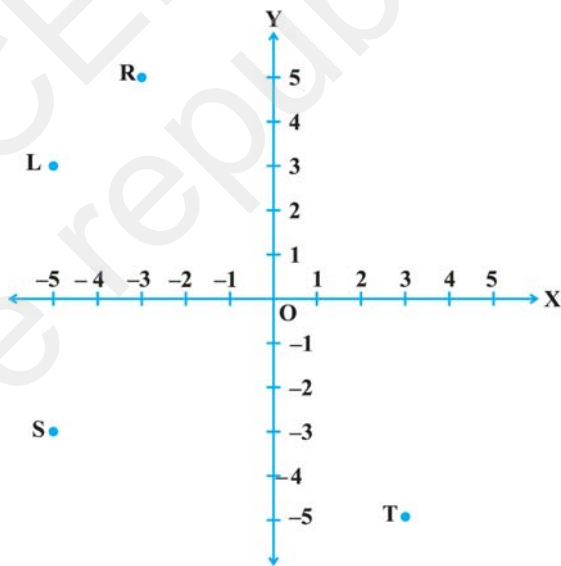

Fig. 3.2

23. The point which lies on y-axis at a distance of 5 units in the negative direction of y-axis is

- (A) $(0, 5)$ (B) $(5, 0)$
- (C) $(0, -5)$ (D) $(-5, 0)$

24. The perpendicular distance of the point $P(3, 4)$ from the y-axis is

- (A) 3 (B) 4
- (C) 5 (D) 7

(C) Short Answer Questions with Reasoning

Sample Question 1 : Write whether the following statements are **True** or **False**? Justify your answer.

- (i) Point $(0, -2)$ lies on y -axis.
- (ii) The perpendicular distance of the point $(4, 3)$ from the x -axis is 4.

Solution :

- (i) True, because a point on the y -axis is of the form $(0, y)$.
- (ii) False, because the perpendicular distance of a point from the x -axis is its ordinate. Hence it is 3, not 4.

EXERCISE 3.2

1. Write whether the following statements are True or False? Justify your answer.
 - (i) Point $(3, 0)$ lies in the first quadrant.
 - (ii) Points $(1, -1)$ and $(-1, 1)$ lie in the same quadrant.
 - (iii) The coordinates of a point whose ordinate is $-\frac{1}{2}$ and abscissa is 1 are $\left(-\frac{1}{2}, 1\right)$.
 - (iv) A point lies on y -axis at a distance of 2 units from the x -axis. Its coordinates are $(2, 0)$.
 - (v) $(-1, 7)$ is a point in the II quadrant.

(D) Short Answer Questions

Sample Question 1 : Plot the point $P(-6, 2)$ and from it draw PM and PN as perpendiculars to x -axis and y -axis, respectively. Write the coordinates of the points M and N .

Solution :

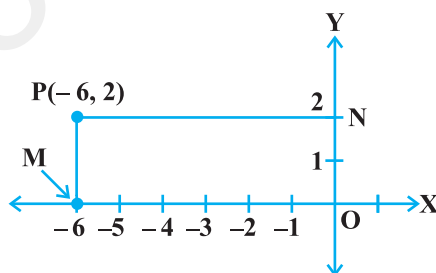

Fig. 3.3

From the graph, we see that $M(-6, 0)$ and $N(0, 2)$.

Sample Question 2 : From the Fig. 3.4, write the following:

- (i) Coordinates of B, C and E
- (ii) The point identified by the coordinates $(0, -2)$
- (iii) The abscissa of the point H
- (iv) The ordinate of the point D

Solution :

- (i) $B = (-5, 2)$, $C(-2, -3)$,
 $E = (3, -1)$
- (ii) F
- (iii) 1
- (iv) 0

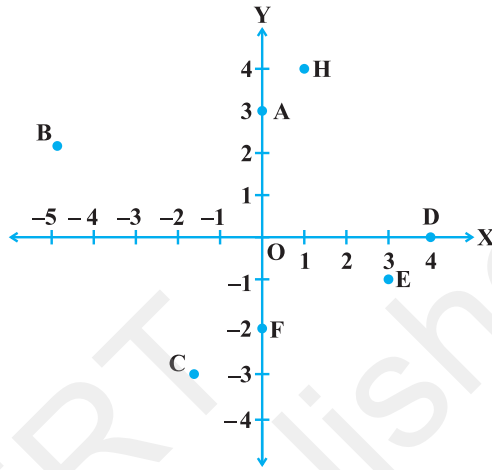

Fig. 3.4

EXERCISE 3.3

1. Write the coordinates of each of the points P, Q, R, S, T and O from the Fig. 3.5.

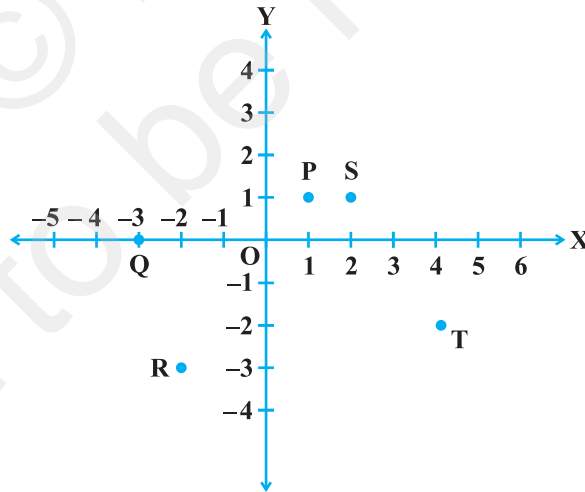

Fig. 3.5

2. Plot the following points and write the name of the figure obtained by joining them in order:

P(-3, 2), Q(-7, -3), R(6, -3), S(2, 2)

3. Plot the points (x, y) given by the following table:

x	2	4	-3	-2	3	0
y	4	2	0	5	-3	0

4. Plot the following points and check whether they are collinear or not :

(i) (1, 3), (-1, -1), (-2, -3)

(ii) (1, 1), (2, -3), (-1, -2)

(iii) (0, 0), (2, 2), (5, 5)

5. Without plotting the points indicate the quadrant in which they will lie, if

(i) ordinate is 5 and abscissa is -3

(ii) abscissa is -5 and ordinate is -3

(iii) abscissa is -5 and ordinate is 3

(iv) ordinate is 5 and abscissa is 3

6. In Fig. 3.6, LM is a line parallel to the y-axis at a distance of 3 units.

(i) What are the coordinates of the points P, R and Q?

(ii) What is the difference between the abscissa of the points L and M?

7. In which quadrant or on which axis each of the following points lie?

(-3, 5), (4, -1), (2, 0), (2, 2), (-3, -6)

8. Which of the following points lie on y-axis?

A (1, 1), B (1, 0), C (0, 1), D (0, 0), E (0, -1), F (-1, 0), G (0, 5), H (-7, 0), I (3, 3).

9. Plot the points (x, y) given by the following table. Use scale 1 cm = 0.25 units

x	1.25	0.25	1.5	-1.75
y	-0.5	1	1.5	-0.25

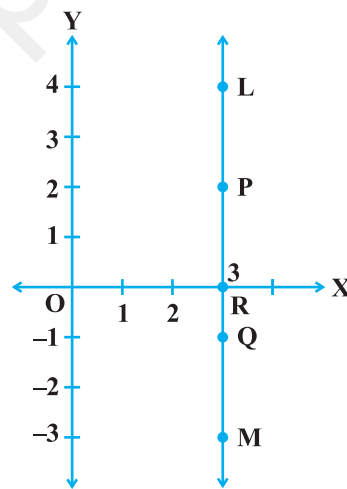

Fig. 3.6

10. A point lies on the x -axis at a distance of 7 units from the y -axis. What are its coordinates? What will be the coordinates if it lies on y -axis at a distance of -7 units from x -axis?
11. Find the coordinates of the point
- which lies on x and y axes both.
 - whose ordinate is -4 and which lies on y -axis.
 - whose abscissa is 5 and which lies on x -axis.
12. Taking 0.5 cm as 1 unit, plot the following points on the graph paper :
A (1, 3), B (− 3, − 1), C (1, − 4), D (− 2, 3), E (0, − 8), F (1, 0)

(E) Long Answer Questions

Sample Question 1 : Three vertices of a rectangle are (3, 2), (− 4, 2) and (− 4, 5). Plot these points and find the coordinates of the fourth vertex.

Solution : Plot the three vertices of the rectangle as A(3, 2), B(− 4, 2), C(− 4, 5) (see Fig. 3.7).

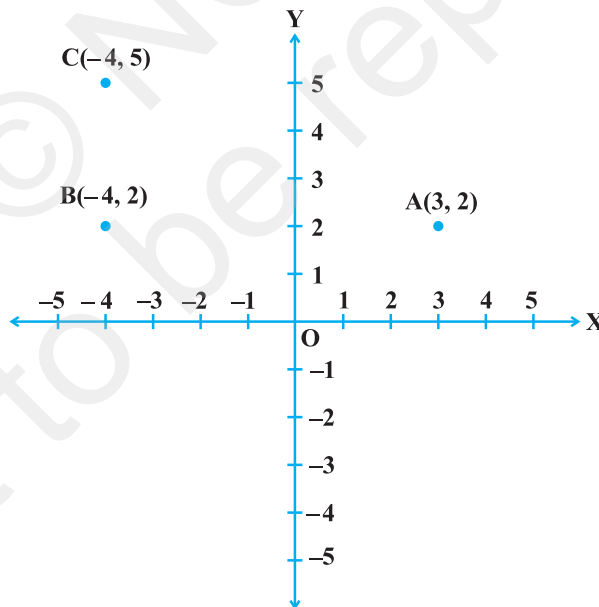

Fig. 3.7

We have to find the coordinates of the fourth vertex D so that ABCD is a rectangle. Since the opposite sides of a rectangle are equal, so the abscissa of D should be equal to abscissa of A, i.e., 3 and the ordinate of D should be equal to the ordinate of C, i.e., 5.

So, the coordinates of D are (3, 5).

EXERCISE 3.4

- Points A (5, 3), B (−2, 3) and D (5, −4) are three vertices of a square ABCD. Plot these points on a graph paper and hence find the coordinates of the vertex C.
- Write the coordinates of the vertices of a rectangle whose length and breadth are 5 and 3 units respectively, one vertex at the origin, the longer side lies on the x -axis and one of the vertices lies in the third quadrant.
- Plot the points P (1, 0), Q (4, 0) and S (1, 3). Find the coordinates of the point R such that PQRS is a square.
- From the Fig. 3.8, answer the following :

- Write the points whose abscissa is 0.
- Write the points whose ordinate is 0.
- Write the points whose abscissa is −5.

- Plot the points A (1, −1) and B (4, 5)

- Draw a line segment joining these points. Write the coordinates of a point on this line segment between the points A and B.

- Extend this line segment and write the coordinates of a point on this line which lies outside the line segment AB.

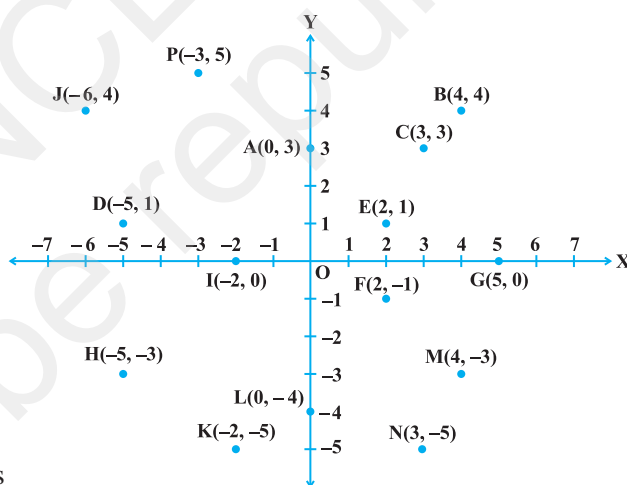

Fig. 3.8

LINEAR EQUATIONS IN TWO VARIABLES

(A) Main Concepts and Results

An equation is a statement in which one expression equals to another expression. An equation of the form $ax + by + c = 0$, where a , b and c are real numbers such that $a \neq 0$ and $b \neq 0$, is called a linear equation in two variables. The process of finding solution(s) is called solving an equation.

The solution of a linear equation is not affected when

- (i) the same number is added to (subtracted from) both sides of the equation,
- (ii) both sides of the equation are multiplied or divided by the same non-zero number.

Further, a linear equation in two variables has infinitely many solutions. The graph of every linear equation in two variables is a straight line and every point on the graph (straight line) represents a solution of the linear equation. Thus, every solution of the linear equation can be represented by a unique point on the graph of the equation. The graphs of $x = a$ and $y = a$ are lines parallel to the y -axis and x -axis, respectively.

(B) Multiple Choice Questions

Write the correct answer:

Sample Question 1 : The linear equation $3x - y = x - 1$ has :

- | | |
|-------------------------------|-------------------|
| (A) A unique solution | (B) Two solutions |
| (C) Infinitely many solutions | (D) No solution |

Solution : Answer (C)

Sample Question 2 : A linear equation in two variables is of the form $ax + by + c = 0$, where

- (A) $a \neq 0, b \neq 0$ (B) $a = 0, b \neq 0$ (C) $a \neq 0, b = 0$ (D) $a = 0, c = 0$

Solution : Answer (A)

Sample Question 3 : Any point on the y -axis is of the form

- (A) $(x, 0)$ (B) (x, y) (C) $(0, y)$ (D) (y, y)

Solution : Answer (C)

EXERCISE 4.1

Write the correct answer in each of the following :

- The linear equation $2x - 5y = 7$ has

(A) A unique solution (B) Two solutions
(C) Infinitely many solutions (D) No solution
- The equation $2x + 5y = 7$ has a unique solution, if x, y are :

(A) Natural numbers (B) Positive real numbers
(C) Real numbers (D) Rational numbers
- If $(2, 0)$ is a solution of the linear equation $2x + 3y = k$, then the value of k is

(A) 4 (B) 6 (C) 5 (D) 2
- Any solution of the linear equation $2x + 0y + 9 = 0$ in two variables is of the form

(A) $(-\frac{9}{2}, m)$ (B) $(n, -\frac{9}{2})$
(C) $(0, -\frac{9}{2})$ (D) $(-9, 0)$
- The graph of the linear equation $2x + 3y = 6$ cuts the y -axis at the point

(A) $(2, 0)$ (B) $(0, 3)$ (C) $(3, 0)$ (D) $(0, 2)$
- The equation $x = 7$, in two variables, can be written as

(A) $1 \cdot x + 1 \cdot y = 7$ (B) $1 \cdot x + 0 \cdot y = 7$
(C) $0 \cdot x + 1 \cdot y = 7$ (D) $0 \cdot x + 0 \cdot y = 7$
- Any point on the x -axis is of the form

(A) (x, y) (B) $(0, y)$ (C) $(x, 0)$ (D) (x, x)
- Any point on the line $y = x$ is of the form

(A) (a, a) (B) $(0, a)$ (C) $(a, 0)$ (D) $(a, -a)$

9. The equation of x -axis is of the form
(A) $x = 0$ (B) $y = 0$ (C) $x + y = 0$ (D) $x = y$
10. The graph of $y = 6$ is a line
(A) parallel to x -axis at a distance 6 units from the origin
(B) parallel to y -axis at a distance 6 units from the origin
(C) making an intercept 6 on the x -axis.
(D) making an intercept 6 on both the axes.
11. $x = 5, y = 2$ is a solution of the linear equation
(A) $x + 2y = 7$ (B) $5x + 2y = 7$ (C) $x + y = 7$ (D) $5x + y = 7$
12. If a linear equation has solutions $(-2, 2), (0, 0)$ and $(2, -2)$, then it is of the form
(A) $y - x = 0$ (B) $x + y = 0$
(C) $-2x + y = 0$ (D) $-x + 2y = 0$
13. The positive solutions of the equation $ax + by + c = 0$ always lie in the
(A) 1st quadrant (B) 2nd quadrant
(C) 3rd quadrant (D) 4th quadrant
14. The graph of the linear equation $2x + 3y = 6$ is a line which meets the x -axis at the point
(A) $(0, 2)$ (B) $(2, 0)$ (C) $(3, 0)$ (D) $(0, 3)$
15. The graph of the linear equation $y = x$ passes through the point
(A) $\left(\frac{3}{2}, \frac{-3}{2}\right)$ (B) $\left(0, \frac{3}{2}\right)$ (C) $(1, 1)$ (D) $\left(\frac{-1}{2}, \frac{1}{2}\right)$
16. If we multiply or divide both sides of a linear equation with a non-zero number, then the solution of the linear equation :
(A) Changes
(B) Remains the same
(C) Changes in case of multiplication only
(D) Changes in case of division only
17. How many linear equations in x and y can be satisfied by $x = 1$ and $y = 2$?
(A) Only one (B) Two (C) Infinitely many (D) Three
18. The point of the form (a, a) always lies on :
(A) x -axis (B) y -axis
(C) On the line $y = x$ (D) On the line $x + y = 0$

19. The point of the form $(a, -a)$ always lies on the line

- (A) $x = a$ (B) $y = -a$ (C) $y = x$ (D) $x + y = 0$

(C) Short Answer Questions with Reasoning

Sample Question 1 : Write whether the following statements are **True** or **False**? Justify your answers.

- (i) $ax + by + c = 0$, where a, b and c are real numbers, is a linear equation in two variables.
- (ii) A linear equation $2x + 3y = 5$ has a unique solution.
- (iii) All the points $(2, 0)$, $(-3, 0)$, $(4, 2)$ and $(0, 5)$ lie on the x -axis.
- (iv) The line parallel to the y -axis at a distance 4 units to the left of y -axis is given by the equation $x = -4$.
- (v) The graph of the equation $y = mx + c$ passes through the origin.

Solution :

- (i) False, because $ax + by + c = 0$ is a linear equation in two variables if both a and b are non-zero.
- (ii) False, because a linear equation in two variables has infinitely many solutions.
- (iii) False, the points $(2, 0)$, $(-3, 0)$ lie on the x -axis. The point $(4, 2)$ lies in the first quadrant. The point $(0, 5)$ lies on the y -axis.
- (iv) True, since the line parallel to y -axis at a distance a units to the left of y -axis is given by the equation $x = -a$.
- (v) False, because $x = 0, y = 0$ does not satisfy the equation.

Sample Question 2 : Write whether the following statement is **True** or **False**? Justify your answer.

The coordinates of points given in the table :

x	0	1	2	3	4
y	2	4	6	8	10

represent some of the solutions of the equation $2x + 2 = y$.

Solution : True, since on looking at the coordinates, we observe that each y -coordinate is two units more than double the x -coordinate.

EXERCISE 4.2

Write whether the following statements are True or False? Justify your answers :

1. The point (0, 3) lies on the graph of the linear equation $3x + 4y = 12$.
2. The graph of the linear equation $x + 2y = 7$ passes through the point (0, 7).
3. The graph given below represents the linear equation $x + y = 0$.

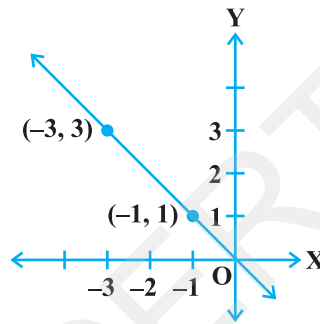

Fig. 4.1

4. The graph given below represents the linear equation $x = 3$ (see Fig. 4.2).
5. The coordinates of points in the table:

x	0	1	2	3	4
y	2	3	4	-5	6

represent some of the solutions of the equation $x - y + 2 = 0$.

6. Every point on the graph of a linear equation in two variables does not represent a solution of the linear equation.
7. The graph of every linear equation in two variables need not be a line.

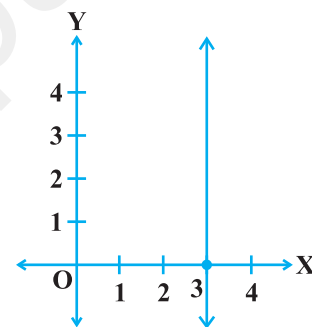

Fig. 4.2

(D) Short Answer Questions

Sample Question 1 : Find the points where the graph of the equation $3x + 4y = 12$ cuts the x -axis and the y -axis.

Solution : The graph of the linear equation $3x + 4y = 12$ cuts the x -axis at the point where $y = 0$. On putting $y = 0$ in the linear equation, we have $3x = 12$, which gives $x = 4$. Thus, the required point is (4, 0).

The graph of the linear equation $3x + 4y = 12$ cuts the y -axis at the point where $x = 0$. On putting $x = 0$ in the given equation, we have $4y = 12$, which gives $y = 3$. Thus, the required point is $(0, 3)$.

Sample Question 2 : At what point does the graph of the linear equation $x + y = 5$ meet a line which is parallel to the y -axis, at a distance 2 units from the origin and in the positive direction of x -axis.

Solution : The coordinates of the points lying on the line parallel to the y -axis, at a distance 2 units from the origin and in the positive direction of the x -axis are of the form $(2, a)$. Putting $x = 2, y = a$ in the equation $x + y = 5$, we get $a = 3$. Thus, the required point is $(2, 3)$.

Sample Question 3 : Determine the point on the graph of the equation $2x + 5y = 20$

whose x -coordinate is $\frac{5}{2}$ times its ordinate.

Solution : As the x -coordinate of the point is $\frac{5}{2}$ times its ordinate, therefore, $x = \frac{5}{2}y$.

Now putting $x = \frac{5}{2}y$ in $2x + 5y = 20$, we get, $y = 2$. Therefore, $x = 5$. Thus, the required point is $(5, 2)$.

Sample Question 4 : Draw the graph of the equation represented by the straight line which is parallel to the x -axis and is 4 units above it.

Solution : Any straight line parallel to x -axis is given by $y = k$, where k is the distance of the line from the x -axis. Here $k = 4$. Therefore, the equation of the line is $y = 4$. To draw the graph of this equation, plot the points $(1, 4)$ and $(2, 4)$ and join them. This is the required graph (see Fig. 4.3).

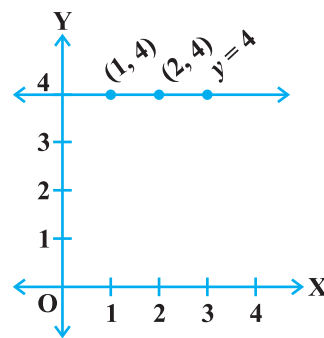

Fig. 4.3

EXERCISE 4.3

1. Draw the graphs of linear equations $y = x$ and $y = -x$ on the same cartesian plane. What do you observe?

2. Determine the point on the graph of the linear equation $2x + 5y = 19$, whose ordinate is $1\frac{1}{2}$ times its abscissa.
3. Draw the graph of the equation represented by a straight line which is parallel to the x -axis and at a distance 3 units below it.
4. Draw the graph of the linear equation whose solutions are represented by the points having the sum of the coordinates as 10 units.
5. Write the linear equation such that each point on its graph has an ordinate 3 times its abscissa.
6. If the point $(3, 4)$ lies on the graph of $3y = ax + 7$, then find the value of a .
7. How many solution(s) of the equation $2x + 1 = x - 3$ are there on the :
 - (i) Number line
 - (ii) Cartesian plane
8. Find the solution of the linear equation $x + 2y = 8$ which represents a point on
 - (i) x -axis
 - (ii) y -axis
9. For what value of c , the linear equation $2x + cy = 8$ has equal values of x and y for its solution.
10. Let y varies directly as x . If $y = 12$ when $x = 4$, then write a linear equation. What is the value of y when $x = 5$?

(E) Long Answer Questions

Sample Question 1 : Draw the graph of the linear equation $2x + 3y = 12$. At what points, the graph of the equation cuts the x -axis and the y -axis?

Solution : The given equation is $2x + 3y = 12$. To draw the graph of this equation, we need at least two points lying on the graph.

From the equation, we have $y = \frac{12-2x}{3}$

For $x=0, y=4$, therefore, $(0, 4)$ lies on the graph.

For $y=0, x=6$, therefore, $(6, 0)$ lies on the graph.

Now plot the points A $(0, 4)$ and B $(6, 0)$ and join them (see Fig 4.4), to get the line AB. Line AB is the required graph.

You can see that the graph (line AB) cuts the x -axis at the point $(6, 0)$ and the y -axis at the point $(0, 4)$.

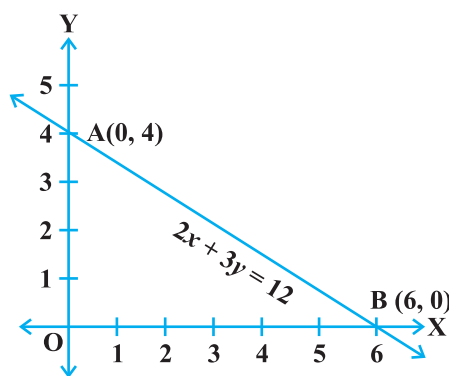

Fig. 4.4

Sample Question 2 : The following values of x and y are thought to satisfy a linear equation :

x	1	2
y	1	3

Draw the graph, using the values of x, y as given in the above table.

At what point the graph of the linear equation

- (i) cuts the x -axis. (ii) cuts the y -axis.

Solution : From the table, we get two points A (1, 1) and B (2, 3) which lie on the graph of the linear equation. Obviously, the graph will be a straight line. So, we first plot the points A and B and join them as shown in the Fig 4.5.

From the Fig 4.5, we see that the graph cuts the

x -axis at the point $\left(\frac{1}{2}, 0\right)$ and the y -axis at the point (0, -1).

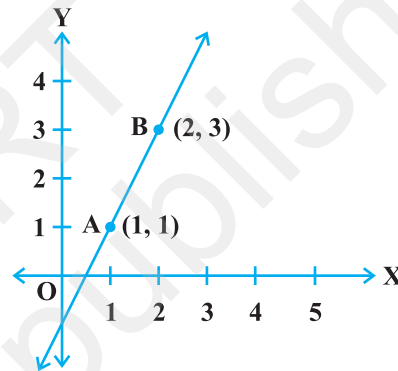

Fig. 4.5

Sample Question 3 : The Autorikshaw fare in a city is charged Rs 10 for the first kilometer and @ Rs 4 per kilometer for subsequent distance covered. Write the linear equation to express the above statement. Draw the graph of the linear equation.

Solution : Let the total distance covered be x km and the fare charged Rs y . Then for the first km, fare charged is Rs 10 and for remaining $(x - 1)$ km fare charged is Rs $4(x - 1)$.

Therefore, $y = 10 + 4(x - 1) = 4x + 6$

The required equation is $y = 4x + 6$. Now, when $x = 0, y = 6$ and when $x = -1, y = 2$. The graph is given in Fig 4.6.

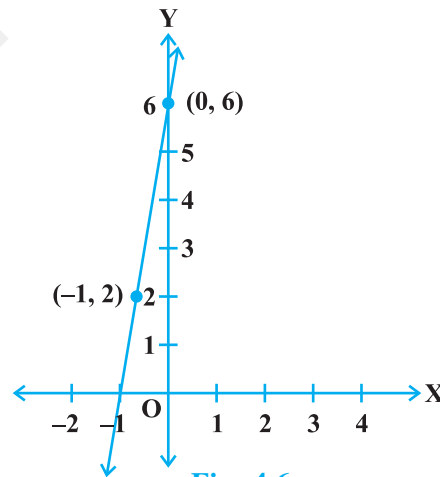

Fig. 4.6

Sample Question 4 : The work done by a body on application of a constant force is the product of the constant force and the distance travelled by the body in the direction of force. Express this in the form of a linear equation in two variables and draw its

graph by taking the constant force as 3 units. What is the work done when the distance travelled is 2 units. Verify it by plotting the graph.

Solution: Work done = (constant force) \times (distance)
 $= 3 \times$ (distance),

i.e., $y = 3x$, where y (units) is the work done and x (units) is the distance travelled. Since $x = 2$ units (given), therefore, work done = 6 units. To plot the graph of the linear equation $y = 3x$, we need at least two solutions of the equation. We see that $x = 0, y = 0$ satisfies the given equation also $x = 1, y = 3$ satisfies the equation.

Now we plot the points A (0, 0) and B (1, 3) and join AB (see Fig. 4.7). The graph of the equation is a straight line. [We have not shown the whole line because work done cannot be negative].

To verify from the graph, draw a perpendicular to the x -axis at the point (2, 0) meeting the graph at the point C. Clearly the coordinates of C are (2, 6). It means that the work done is 6 units.

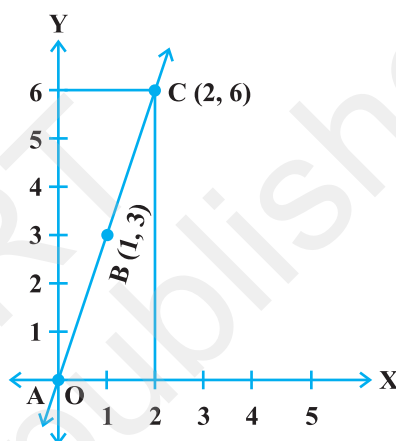

Fig. 4.7

EXERCISE 4.4

1. Show that the points A (1, 2), B (-1, -16) and C (0, -7) lie on the graph of the linear equation $y = 9x - 7$.
2. The following observed values of x and y are thought to satisfy a linear equation. Write the linear equation :

x	6	-6
y	-2	6

Draw the graph using the values of x, y as given in the above table.

At what points the graph of the linear equation

- (i) cuts the x -axis
 - (ii) cuts the y -axis
3. Draw the graph of the linear equation $3x + 4y = 6$. At what points, the graph cuts the x -axis and the y -axis.

4. The linear equation that converts Fahrenheit (F) to Celsius (C) is given by the relation

$$C = \frac{5F - 160}{9}$$

- (i) If the temperature is 86°F , what is the temperature in Celsius?
 - (ii) If the temperature is 35°C , what is the temperature in Fahrenheit?
 - (iii) If the temperature is 0°C what is the temperature in Fahrenheit and if the temperature is 0°F , what is the temperature in Celsius?
 - (iv) What is the numerical value of the temperature which is same in both the scales?
5. If the temperature of a liquid can be measured in Kelvin units as $x^{\circ}\text{K}$ or in Fahrenheit units as $y^{\circ}\text{F}$, the relation between the two systems of measurement of temperature is given by the linear equation

$$y = \frac{9}{5}(x - 273) + 32$$

- (i) Find the temperature of the liquid in Fahrenheit if the temperature of the liquid is 313°K .
 - (ii) If the temperature is 158°F , then find the temperature in Kelvin.
6. The force exerted to pull a cart is directly proportional to the acceleration produced in the body. Express the statement as a linear equation of two variables and draw the graph of the same by taking the constant mass equal to 6 kg. Read from the graph, the force required when the acceleration produced is (i) 5 m/sec^2 , (ii) 6 m/sec^2 .

INTRODUCTION TO EUCLID'S GEOMETRY

(A) Main Concepts and Results

Points, Line, Plane or surface, Axiom, Postulate and Theorem, The Elements, Shapes of altars or vedis in ancient India, Equivalent versions of Euclid's fifth Postulate, Consistency of a system of axioms.

Ancient India

- The geometry of the Vedic period originated with the construction of altars (or vedis) and fireplaces for performing Vedic rites. Square and circular altars were used for household rituals, while altars, whose shapes were combinations of rectangles, triangles and trapeziums, were required for public worship.

Egypt, Babylonia and Greece

- Egyptians developed a number of geometric techniques and rules for calculating simple areas and doing simple constructions. Babylonians and Egyptians used geometry mostly for practical purposes and did very little to develop it as a systematic science. The Greeks were interested in establishing the truth of the statements they discovered using deductive reasoning. A Greek mathematician, Thales is credited with giving the first known proof.

Euclid's Elements

- Euclid around 300 B.C. collected all known work in the field of mathematics and arranged it in his famous treatise called **Elements**. Euclid assumed certain properties, which were not to be proved. These assumptions are actually "obvious universal truths". He divided them into two types.

Axioms

1. The things which are equal to the same thing are equal to one another.
2. If equals be added to the equals, the wholes are equal.
3. If equals be subtracted from equals, the remainders are equals.
4. Things which coincide with one another are equal to one another.
5. The whole is greater than the part.
6. Things which are double of the same thing are equal to one another.
7. Things which are halves of the same thing are equal to one another.

Postulates

1. A straight line may be drawn from any point to any other point.
2. A terminated line (line segment) can be produced indefinitely.
3. A circle may be described with any centre and any radius.
4. All right angles are equal to one another.
5. If a straight line falling on two straight lines makes the interior angles on the same side of it, taken together less than two right angles, then the two straight lines if produced indefinitely, meet on that side on which the sum of angles is taken together less than two right angles.

Euclid used the term postulate for the assumptions that were specific to geometry and otherwise called axioms. A **theorem** is a mathematical statement whose truth has been logically established.

Present Day Geometry

- A mathematical system consists of axioms, definitions and undefined terms.
- Point, line and plane are taken as undefined terms.
- A system of axioms is said to be consistent if there are no contradictions in the axioms and theorems that can be derived from them.
- Given two distinct points, there is a unique line passing through them.
- Two distinct lines can not have more than one point in common.
- Playfair's Axiom (An equivalent version of Euclid's fifth postulate).

(B) Multiple Choice Questions

Write the correct answer :

Sample Question 1 : Euclid's second axiom (as per order given in the Textbook for Class IX) is

- (A) The things which are equal to the same thing are equal to one another.
- (B) If equals be added to equals, the wholes are equal.
- (C) If equals be subtracted from equals, the remainders are equals.
- (D) Things which coincide with one another are equal to one another.

Solution : Answer (B)

Sample Question 2 : Euclid's fifth postulate is

- (A) The whole is greater than the part.
- (B) A circle may be described with any centre and any radius.
- (C) All right angles are equal to one another.
- (D) If a straight line falling on two straight lines makes the interior angles on the same side of it taken together less than two right angles, then the two straight lines if produced indefinitely, meet on that side on which the sum of angles is less than two right angles.

Solution : Answer (D)

Sample Question 3 : The things which are double of the same thing are

- (A) equal
- (B) unequal
- (C) halves of the same thing
- (D) double of the same thing

Solution : Answer (A)

Sample Question 4 : Axioms are assumed

- (A) universal truths in all branches of mathematics
- (B) universal truths specific to geometry
- (C) theorems
- (D) definitions

Solution : Answer (A)

Sample Question 5 : John is of the same age as Mohan. Ram is also of the same age as Mohan. State the Euclid's axiom that illustrates the relative ages of John and Ram

- (A) First Axiom
- (B) Second Axiom
- (C) Third Axiom
- (D) Fourth Axiom

Solution : Answer (A)

Sample Question 6 : If a straight line falling on two straight lines makes the interior angles on the same side of it, whose sum is 120° , then the two straight lines, if produced indefinitely, meet on the side on which the sum of angles is

- (A) less than 120° (B) greater than 120°
(C) is equal to 120° (D) greater than 180°

Solution : Answer (C)

EXERCISE 5.1

- The three steps from solids to points are :
(A) Solids - surfaces - lines - points
(B) Solids - lines - surfaces - points
(C) Lines - points - surfaces - solids
(D) Lines - surfaces - points - solids
- The number of dimensions, a solid has :
(A) 1 (B) 2 (C) 3 (D) 0
- The number of dimensions, a surface has :
(A) 1 (B) 2 (C) 3 (D) 0
- The number of dimension, a point has :
(A) 0 (B) 1 (C) 2 (D) 3
- Euclid divided his famous treatise "The Elements" into :
(A) 13 chapters (B) 12 chapters (C) 11 chapters (D) 9 chapters
- The total number of propositions in the Elements are :
(A) 465 (B) 460 (C) 13 (D) 55
- Boundaries of solids are :
(A) surfaces (B) curves (C) lines (D) points
- Boundaries of surfaces are :
(A) surfaces (B) curves (C) lines (D) points
- In Indus Valley Civilisation (about 3000 B.C.), the bricks used for construction work were having dimensions in the ratio
(A) 1 : 3 : 4 (B) 4 : 2 : 1 (C) 4 : 4 : 1 (D) 4 : 3 : 2
- A pyramid is a solid figure, the base of which is
(A) only a triangle (B) only a square
(C) only a rectangle (D) any polygon
- The side faces of a pyramid are :
(A) Triangles (B) Squares (C) Polygons (D) Trapeziums

12. It is known that if $x + y = 10$ then $x + y + z = 10 + z$. The Euclid's axiom that illustrates this statement is :
- (A) First Axiom (B) Second Axiom
(C) Third Axiom (D) Fourth Axiom
13. In ancient India, the shapes of altars used for house hold rituals were :
- (A) Squares and circles (B) Triangles and rectangles
(C) Trapeziums and pyramids (D) Rectangles and squares
14. The number of interwoven isosceles triangles in Sriyantra (in the Atharvaveda) is:
- (A) Seven (B) Eight (C) Nine (D) Eleven
15. Greek's emphasised on :
- (A) Inductive reasoning (B) Deductive reasoning
(C) Both A and B (D) Practical use of geometry
16. In Ancient India, Altars with combination of shapes like rectangles, triangles and trapeziums were used for :
- (A) Public worship (B) Household rituals
(C) Both A and B (D) None of A, B, C
17. Euclid belongs to the country :
- (A) Babylonia (B) Egypt (C) Greece (D) India
18. Thales belongs to the country :
- (A) Babylonia (B) Egypt (C) Greece (D) Rome
19. Pythagoras was a student of :
- (A) Thales (B) Euclid (C) Both A and B (D) Archimedes
20. Which of the following needs a proof ?
- (A) Theorem (B) Axiom (C) Definition (D) Postulate
21. Euclid stated that all right angles are equal to each other in the form of
- (A) an axiom (B) a definition (C) a postulate (D) a proof
22. 'Lines are parallel if they do not intersect' is stated in the form of
- (A) an axiom (B) a definition (C) a postulate (D) a proof

(C) Short Answer Questions with Reasoning

Sample Question 1 : Write whether the following statements are True or False? Justify your answer.

- (i) Pyramid is a solid figure, the base of which is a triangle or square or some other polygon and its side faces are equilateral triangles that converges to a point at the top.
- (ii) In Vedic period, squares and circular shaped altars were used for household rituals, while altars whose shapes were combination of rectangles, triangles and trapeziums were used for public worship.
- (iii) In geometry, we take a point, a line and a plane as undefined terms.
- (iv) If the area of a triangle equals the area of a rectangle and the area of the rectangle equals that of a square, then the area of the triangle also equals the area of the square.
- (v) Euclid's fourth axiom says that everything equals itself.
- (vi) The Euclidean geometry is valid only for figures in the plane.

Solution :

- (i) False. The side faces of a pyramid are triangles not necessarily equilateral triangles.
- (ii) True. The geometry of Vedic period originated with the construction of vedis and fireplaces for performing vedic rites. The location of the sacred fires had to be in accordance to the clearly laid down instructions about their shapes and area.
- (iii) True. To define a point, a line and a plane in geometry we need to define many other things that give a long chain of definitions without an end. For such reasons, mathematicians agree to leave these geometric terms undefined.
- (iv) True. Things equal to the same thing are equal.
- (v) True. It is the justification of the principle of superposition.
- (vi) True. It fails on the curved surfaces. For example on curved surfaces, the sum of angles of a triangle may be more than 180° .

EXERCISE 5.2

Write whether the following statements are **True** or **False**? Justify your answer :

1. Euclidean geometry is valid only for curved surfaces.
2. The boundaries of the solids are curves.
3. The edges of a surface are curves.
4. The things which are double of the same thing are equal to one another.
5. If a quantity B is a part of another quantity A, then A can be written as the sum of B and some third quantity C.
6. The statements that are proved are called axioms.

7. "For every line l and for every point P not lying on a given line l , there exists a unique line m passing through P and parallel to l " is known as Playfair's axiom.
8. Two distinct intersecting lines cannot be parallel to the same line.
9. Attempts to prove Euclid's fifth postulate using the other postulates and axioms led to the discovery of several other geometries.

(D) Short Answer Questions

Sample Question 1 : Ram and Ravi have the same weight. If they each gain weight by 2 kg, how will their new weights be compared ?

Solution : Let x kg be the weight each of Ram and Ravi. On gaining 2 kg, weight of Ram and Ravi will be $(x + 2)$ each. According to Euclid's second axiom, when equals are added to equals, the wholes are equal. So, weight of Ram and Ravi are again equal.

Sample Question 2 : Solve the equation $a - 15 = 25$ and state which axiom do you use here.

Solution : $a - 15 = 25$. On adding 15 to both sides, we have $a - 15 + 15 = 25 + 15 = 40$ (using Euclid's second axiom).

or $a = 40$

Sample Question 3 : In the Fig. 5.1, if

$\angle 1 = \angle 3$, $\angle 2 = \angle 4$ and $\angle 3 = \angle 4$, write the relation between $\angle 1$ and $\angle 2$, using an Euclid's axiom.

Solution : Here, $\angle 3 = \angle 4$, $\angle 1 = \angle 3$ and $\angle 2 = \angle 4$. Euclid's first axiom says, the things which are equal to equal thing are equal to one another.

So, $\angle 1 = \angle 2$.

Sample Question 4 : In Fig. 5.2, we have : $AC = XD$, C is the mid-point of AB and D is the mid-point of XY . Using an Euclid's axiom, show that $AB = XY$.

Solution :

$AB = 2AC$ (C is the mid-point of AB)

$XY = 2XD$ (D is the mid-point of XY)

Also, $AC = XD$ (Given)

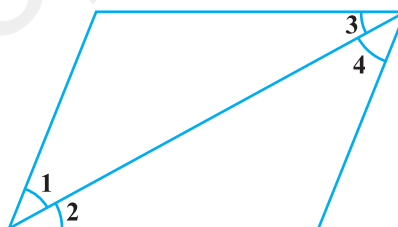

Fig. 5.1

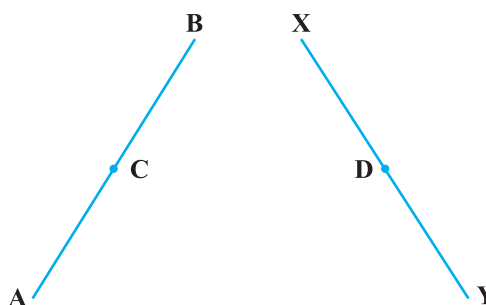

Fig. 5.2

Therefore, $AB = XY$, because things which are double of the same things are equal to one another.

EXERCISE 5.3

Solve each of the following question using appropriate Euclid's axiom :

- Two salesmen make equal sales during the month of August. In September, each salesman doubles his sale of the month of August. Compare their sales in September.
- It is known that $x + y = 10$ and that $x = z$. Show that $z + y = 10$?
- Look at the Fig. 5.3. Show that length $AH >$ sum of lengths of $AB + BC + CD$.



Fig. 5.3

- In the Fig.5.4, we have $AB = BC$, $BX = BY$. Show that $AX = CY$.
- In the Fig.5.5, we have X and Y are the mid-points of AC and BC and $AX = CY$. Show that $AC = BC$.

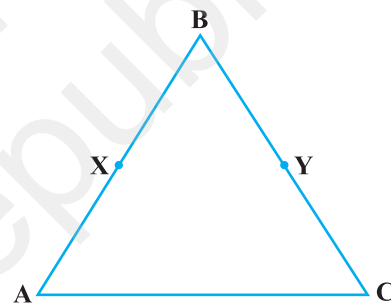

Fig. 5.4

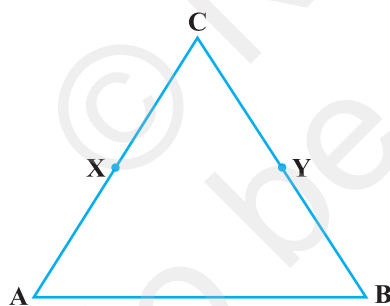

Fig. 5.5

- In the Fig.5.6, we have

$$BX = \frac{1}{2} AB$$

$$BY = \frac{1}{2} BC \text{ and } AB = BC. \text{ Show that}$$

$$BX = BY.$$

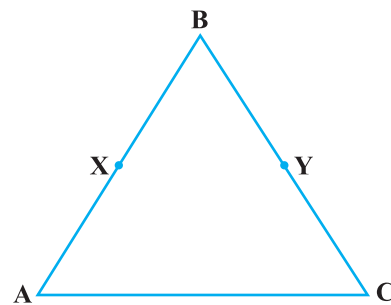

Fig. 5.6

7. In the Fig.5.7, we have $\angle 1 = \angle 2$, $\angle 2 = \angle 3$. Show that $\angle 1 = \angle 3$.
8. In the Fig. 5.8, we have $\angle 1 = \angle 3$ and $\angle 2 = \angle 4$. Show that $\angle A = \angle C$.

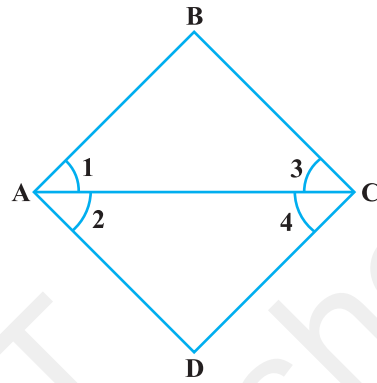

Fig. 5.7

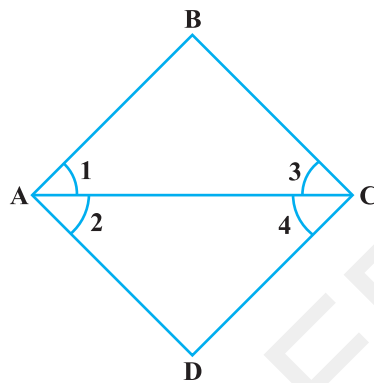

Fig. 5.8

9. In the Fig. 5.9, we have $\angle ABC = \angle ACB$, $\angle 3 = \angle 4$. Show that $\angle 1 = \angle 2$.
10. In the Fig. 5.10, we have $AC = DC$, $CB = CE$. Show that $AB = DE$.

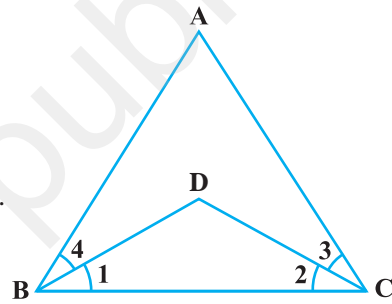

Fig. 5.9

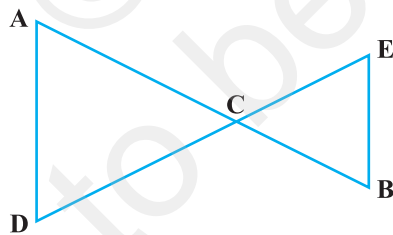

Fig. 5.10

11. In the Fig. 5.11, if $OX = \frac{1}{2} XY$, $PX = \frac{1}{2} XZ$ and $OX = PX$, show that $XY = XZ$.

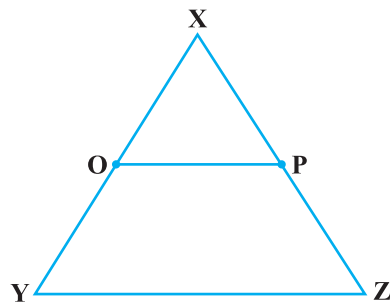

Fig. 5.11

12. In the Fig.5.12 :

- (i) $AB = BC$, M is the mid-point of AB and N is the mid-point of BC . Show that $AM = NC$.
- (ii) $BM = BN$, M is the mid-point of AB and N is the mid-point of BC . Show that $AB = BC$.

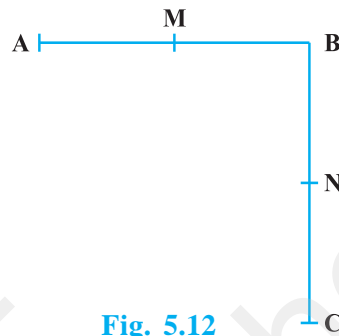

Fig. 5.12

(E) Long Answer Questions

Sample Question 1 : Read the following statement:

“A square is a polygon made up of four line segments, out of which, length of three line segments are equal to the length of fourth one and all its angles are right angles”.

Define the terms used in this definition which you feel necessary. Are there any undefined terms in this? Can you justify that all angles and sides of a square are equal?

Solution : The terms need to be defined are :

Polygon : A simple closed figure made up of three or more line segments.

Line segment : Part of a line with two end points.

Line : Undefined term

Point : Undefined term

Angle : A figure formed by two rays with a common initial point.

Ray : Part of a line with one end point.

Right angle : Angle whose measure is 90° .

Undefined terms used are : line, point.

Euclid's fourth postulate says that “all right angles are equal to one another.”

In a square, all angles are right angles, therefore, all angles are equal (From Euclid's fourth postulate).

Three line segments are equal to fourth line segment (Given).

Therefore, all the four sides of a square are equal. (by Euclid's first axiom “things which are equal to the same thing are equal to one another.”)

EXERCISE 5.4

1. Read the following statement :

An equilateral triangle is a polygon made up of three line segments out of which two line segments are equal to the third one and all its angles are 60° each.

Define the terms used in this definition which you feel necessary. Are there any undefined terms in this? Can you justify that all sides and all angles are equal in an equilateral triangle.

2. Study the following statement:

“Two intersecting lines cannot be perpendicular to the same line”.

Check whether it is an equivalent version to the Euclid's fifth postulate.

[**Hint :** Identify the two intersecting lines l and m and the line n in the above statement.]

3. Read the following statements which are taken as axioms :

- (i) If a transversal intersects two parallel lines, then corresponding angles are not necessarily equal.
- (ii) If a transversal intersect two parallel lines, then alternate interior angles are equal.

Is this system of axioms consistent? Justify your answer.

4. Read the following two statements which are taken as axioms :

- (i) If two lines intersect each other, then the vertically opposite angles are not equal.
- (ii) If a ray stands on a line, then the sum of two adjacent angles so formed is equal to 180° .

Is this system of axioms consistent? Justify your answer.

5. Read the following axioms:

- (i) Things which are equal to the same thing are equal to one another.
- (ii) If equals are added to equals, the wholes are equal.
- (iii) Things which are double of the same thing are equal to one another.

Check whether the given system of axioms is consistent or inconsistent.

LINES AND ANGLES

(A) Main Concepts and Results

Complementary angles, Supplementary angles, Adjacent angles, Linear pair, Vertically opposite angles.

- If a ray stands on a line, then the adjacent angles so formed are supplementary and its converse,
- If two lines intersect, then vertically opposite angles are equal,
- If a transversal intersects two parallel lines, then
 - (i) corresponding angles are equal and conversely,
 - (ii) alternate interior angles are equal and conversely,
 - (iii) interior angles on the same side of the transversal are supplementary and conversely,
- Lines parallel to the same line are parallel to each other,
- Sum of the angles of a triangle is 180° ,
- An exterior angle of a triangle is equal to the sum of the corresponding two interior opposite angles.

(B) Multiple Choice Questions

Write the correct answer:

Sample Question 1 : If two interior angles on the same side of a transversal intersecting two parallel lines are in the ratio 2 : 3, then the greater of the two angles is

- (A) 54° (B) 108° (C) 120° (D) 136°

Solution : Answer (B)

EXERCISE 6.1

Write the correct answer in each of the following:

- In Fig. 6.1, if $AB \parallel CD \parallel EF$, $PQ \parallel RS$, $\angle RQD = 25^\circ$ and $\angle CQP = 60^\circ$, then $\angle QRS$ is equal to
 (A) 85° (B) 135°
 (C) 145° (D) 110°
- If one angle of a triangle is equal to the sum of the other two angles, then the triangle is
 (A) an isosceles triangle
 (B) an obtuse triangle
 (C) an equilateral triangle
 (D) a right triangle
- An exterior angle of a triangle is 105° and its two interior opposite angles are equal. Each of these equal angles is
 (A) $37\frac{1}{2}^\circ$ (B) $52\frac{1}{2}^\circ$ (C) $72\frac{1}{2}^\circ$ (D) 75°
- The angles of a triangle are in the ratio $5 : 3 : 7$. The triangle is
 (A) an acute angled triangle (B) an obtuse angled triangle
 (C) a right triangle (D) an isosceles triangle
- If one of the angles of a triangle is 130° , then the angle between the bisectors of the other two angles can be
 (A) 50° (B) 65° (C) 145° (D) 155°
- In Fig. 6.2, POQ is a line. The value of x is
 (A) 20° (B) 25° (C) 30° (D) 35°

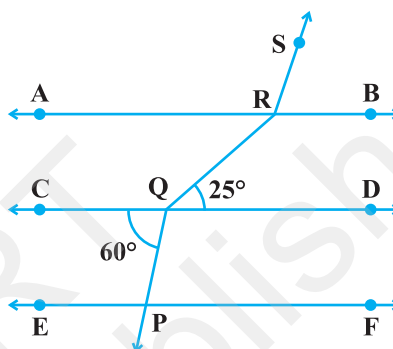

Fig. 6.1

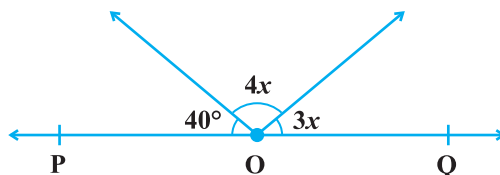

Fig. 6.2

7. In Fig. 6.3, if $OP \parallel RS$, $\angle OPQ = 110^\circ$ and $\angle QRS = 130^\circ$, then $\angle PQR$ is equal to
 (A) 40° (B) 50° (C) 60° (D) 70°

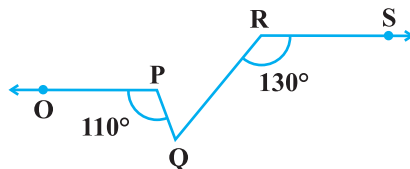

Fig. 6.3

8. Angles of a triangle are in the ratio 2 : 4 : 3. The smallest angle of the triangle is
 (A) 60° (B) 40° (C) 80° (D) 20°

(C) Short Answer Questions with Reasoning

Sample Question 1 :

Let OA, OB, OC and OD are rays in the anticlockwise direction such that $\angle AOB = \angle COD = 100^\circ$, $\angle BOC = 82^\circ$ and $\angle AOD = 78^\circ$. Is it true to say that AOC and BOD are lines?

Solution : AOC is not a line, because $\angle AOB + \angle COB = 100^\circ + 82^\circ = 182^\circ$, which is not equal to 180° . Similarly, BOD is also not a line.

Sample Question 2 : A transversal intersects two lines in such a way that the two interior angles on the same side of the transversal are equal. Will the two lines always be parallel? Give reason for your answer.

Solution : In general, the two lines will not be parallel, because the sum of the two equal angles will not always be 180° . Lines will be parallel when each equal angle is equal to 90° .

EXERCISE 6.2

- For what value of $x + y$ in Fig. 6.4 will ABC be a line? Justify your answer.
- Can a triangle have all angles less than 60° ? Give reason for your answer.
- Can a triangle have two obtuse angles? Give reason for your answer.
- How many triangles can be drawn having its angles as 45° , 64° and 72° ? Give reason for your answer.

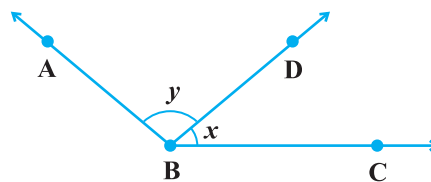

Fig. 6.4

5. How many triangles can be drawn having its angles as 53° , 64° and 63° ? Give reason for your answer.
6. In Fig. 6.5, find the value of x for which the lines l and m are parallel.
7. Two adjacent angles are equal. Is it necessary that each of these angles will be a right angle? Justify your answer.
8. If one of the angles formed by two intersecting lines is a right angle, what can you say about the other three angles? Give reason for your answer.
9. In Fig.6.6, which of the two lines are parallel and why?

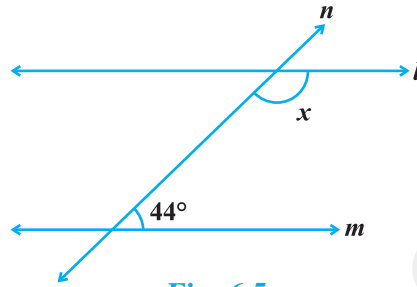

Fig. 6.5

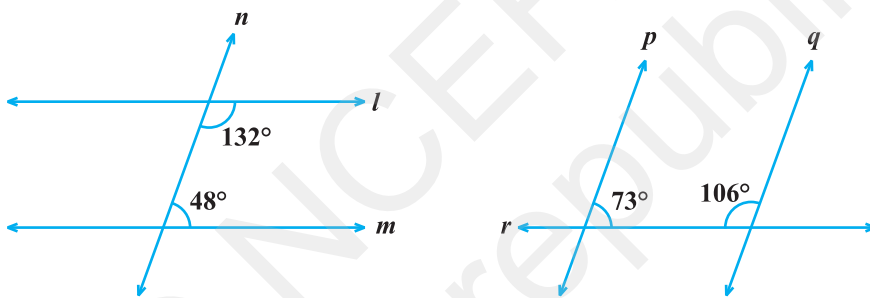

Fig. 6.6

10. Two lines l and m are perpendicular to the same line n . Are l and m perpendicular to each other? Give reason for your answer.

(D) Short Answer Questions

Sample Question 1 : In Fig. 6.7, AB, CD and EF are three lines concurrent at O. Find the value of y .

Solution : $\angle AOE = \angle BOF = 5y$
(Vertically opposite angles)

Also,
 $\angle COE + \angle AOE + \angle AOD = 180^\circ$

So, $2y + 5y + 2y = 180^\circ$

or, $9y = 180^\circ$, which gives $y = 20^\circ$.

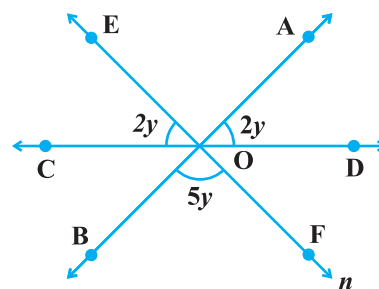

Fig. 6.7

Sample Question 2 : In Fig.6.8, $x = y$ and $a = b$.

Prove that $l \parallel n$.

Solution: $x = y$ (Given)

Therefore, $l \parallel m$ (Corresponding angles) (1)

Also, $a = b$ (Given)

Therefore, $n \parallel m$ (Corresponding angles) (2)

From (1) and (2), $l \parallel n$ (Lines parallel to the same line)

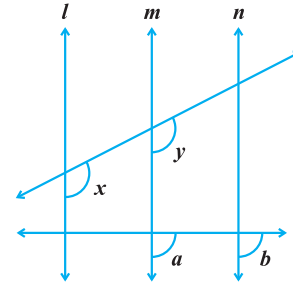

Fig. 6.8

EXERCISE 6.3

- In Fig. 6.9, OD is the bisector of $\angle AOC$, OE is the bisector of $\angle BOC$ and $OD \perp OE$. Show that the points A, O and B are collinear.

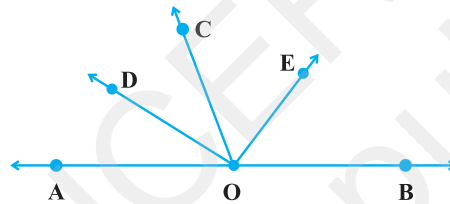

Fig. 6.9

- In Fig. 6.10, $\angle 1 = 60^\circ$ and $\angle 6 = 120^\circ$. Show that the lines m and n are parallel.

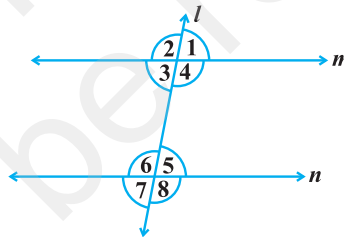

Fig. 6.10

- AP and BQ are the bisectors of the two alternate interior angles formed by the intersection of a transversal t with parallel lines l and m (Fig. 6.11). Show that $AP \parallel BQ$.

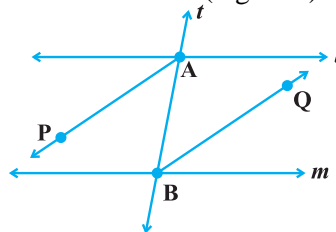

Fig. 6.11

4. If in Fig. 6.11, bisectors AP and BQ of the alternate interior angles are parallel, then show that $l \parallel m$.
5. In Fig. 6.12, $BA \parallel ED$ and $BC \parallel EF$. Show that $\angle ABC = \angle DEF$
[Hint: Produce DE to intersect BC at P (say)].

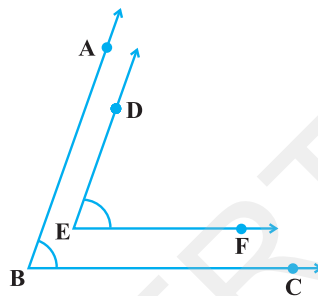

Fig. 6.12

6. In Fig. 6.13, $BA \parallel ED$ and $BC \parallel EF$. Show that $\angle ABC + \angle DEF = 180^\circ$

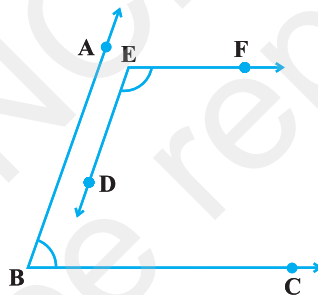

Fig. 6.13

7. In Fig. 6.14, $DE \parallel QR$ and AP and BP are bisectors of $\angle EAB$ and $\angle RBA$, respectively. Find $\angle APB$.

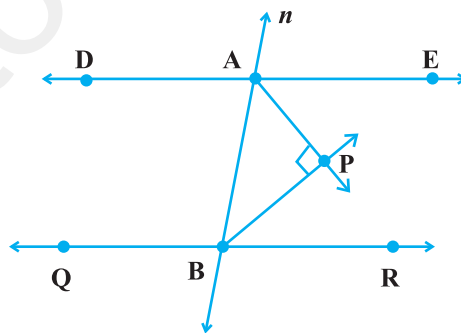

Fig. 6.14

8. The angles of a triangle are in the ratio 2 : 3 : 4. Find the angles of the triangle.
9. A triangle ABC is right angled at A. L is a point on BC such that $AL \perp BC$. Prove that $\angle BAL = \angle ACB$.
10. Two lines are respectively perpendicular to two parallel lines. Show that they are parallel to each other.

(E) Long Answer Questions

Sample Question 1: In Fig. 6.15, m and n are two plane mirrors perpendicular to each other. Show that incident ray CA is parallel to reflected ray BD.

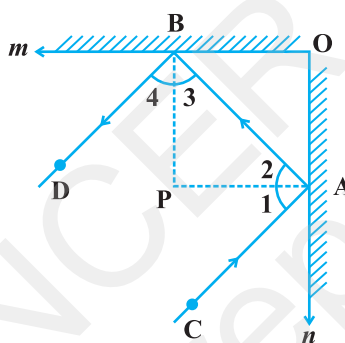

Fig. 6.15

Solution: Let normals at A and B meet at P.

As mirrors are perpendicular to each other, therefore, $BP \parallel OA$ and $AP \parallel OB$.

So, $BP \perp PA$, i.e., $\angle BPA = 90^\circ$

Therefore, $\angle 3 + \angle 2 = 90^\circ$ (Angle sum property) (1)

Also, $\angle 1 = \angle 2$ and $\angle 4 = \angle 3$ (Angle of incidence = Angle of reflection)

Therefore, $\angle 1 + \angle 4 = 90^\circ$ [From (1)] (2)

Adding (1) and (2), we have

$$\angle 1 + \angle 2 + \angle 3 + \angle 4 = 180^\circ$$

i.e., $\angle CAB + \angle DBA = 180^\circ$

Hence, $CA \parallel BD$

Sample Question 2: Prove that the sum of the three angles of a triangle is 180° .

Solution: See proof of Theorem 6.7 in Class IX Mathematics Textbook.

Sample Question 3: Bisectors of angles B and C of a triangle ABC intersect each other at the point O. Prove that $\angle BOC = 90^\circ +$

$$\frac{1}{2} \angle A.$$

Solution: Let us draw the figure as shown in Fig. 6.16

$$\angle A + \angle ABC + \angle ACB = 180^\circ$$

(Angle sum property of a triangle)

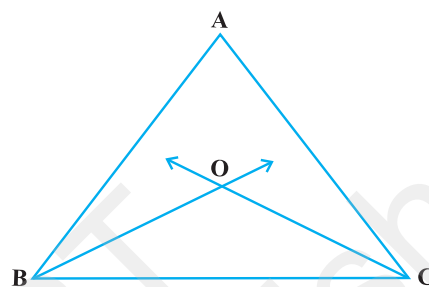

Fig. 6.16

$$\text{Therefore, } \frac{1}{2} \angle A + \frac{1}{2} \angle ABC + \frac{1}{2} \angle ACB = \frac{1}{2} \times 180^\circ = 90^\circ$$

$$\text{i.e., } \frac{1}{2} \angle A + \angle OBC + \angle OCB = 90^\circ \quad (\text{Since BO and CO are}$$

bisectors of $\angle B$ and $\angle C$)

(1)

$$\text{But } \angle BOC + \angle OBC + \angle OCB = 180^\circ \quad (\text{Angle sum property})$$

(2)

Subtracting (1) from (2), we have

$$\angle BOC + \angle OBC + \angle OCB - \frac{1}{2} \angle A - \angle OBC - \angle OCB = 180^\circ - 90^\circ$$

$$\text{i.e., } \angle BOC = 90^\circ + \frac{1}{2} \angle A$$

EXERCISE 6.4

1. If two lines intersect, prove that the vertically opposite angles are equal.
2. Bisectors of interior $\angle B$ and exterior $\angle ACD$ of a ΔABC intersect at the point T. Prove that

$$\angle BTC = \frac{1}{2} \angle BAC.$$

3. A transversal intersects two parallel lines. Prove that the bisectors of any pair of corresponding angles so formed are parallel.

4. Prove that through a given point, we can draw only one perpendicular to a given line.
[Hint: Use proof by contradiction].
5. Prove that two lines that are respectively perpendicular to two intersecting lines intersect each other.
[Hint: Use proof by contradiction].
6. Prove that a triangle must have atleast two acute angles.
7. In Fig. 6.17, $\angle Q > \angle R$, PA is the bisector of $\angle QPR$ and $PM \perp QR$. Prove that $\angle APM = \frac{1}{2} (\angle Q - \angle R)$.

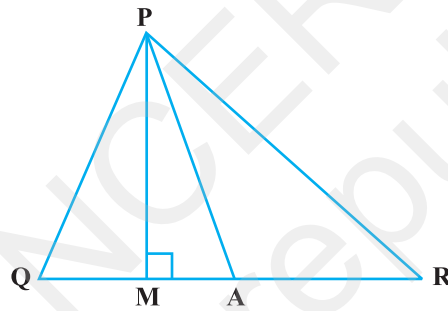

Fig. 6.17

TRIANGLES

(A) Main Concepts and Results

Triangles and their parts, Congruence of triangles, Congruence and correspondence of vertices, Criteria for Congruence of triangles: (i) SAS (ii) ASA (iii) SSS (iv) RHS
AAS criterion for congruence of triangles as a particular case of ASA criterion.

- Angles opposite to equal sides of a triangle are equal,
- Sides opposite to equal angles of a triangle are equal,
- A point equidistant from two given points lies on the perpendicular bisector of the line-segment joining the two points and its converse,
- A point equidistant from two intersecting lines lies on the bisectors of the angles formed by the two lines,
- In a triangle
 - (i) side opposite to the greater angle is longer
 - (ii) angle opposite the longer side is greater
 - (iii) the sum of any two sides is greater than the third side.

(B) Multiple Choice Questions

Write the correct answer :

Sample Question 1 : If $\triangle ABC \cong \triangle PQR$ and $\triangle ABC$ is not congruent to $\triangle RPQ$, then which of the following is not true:

- (A) $BC = PQ$ (B) $AC = PR$ (C) $QR = BC$ (D) $AB = PQ$

Solution : Answer (A)

EXERCISE 7.1

In each of the following, write the correct answer:

1. Which of the following is not a criterion for congruence of triangles?
(A) SAS (B) ASA (C) SSA (D) SSS
2. If $AB = QR$, $BC = PR$ and $CA = PQ$, then
(A) $\triangle ABC \cong \triangle PQR$ (B) $\triangle CBA \cong \triangle PRQ$
(C) $\triangle BAC \cong \triangle RPQ$ (D) $\triangle PQR \cong \triangle BCA$
3. In $\triangle ABC$, $AB = AC$ and $\angle B = 50^\circ$. Then $\angle C$ is equal to
(A) 40° (B) 50° (C) 80° (D) 130°
4. In $\triangle ABC$, $BC = AB$ and $\angle B = 80^\circ$. Then $\angle A$ is equal to
(A) 80° (B) 40° (C) 50° (D) 100°
5. In $\triangle PQR$, $\angle R = \angle P$ and $QR = 4$ cm and $PR = 5$ cm. Then the length of PQ is
(A) 4 cm (B) 5 cm (C) 2 cm (D) 2.5 cm
6. D is a point on the side BC of a $\triangle ABC$ such that AD bisects $\angle BAC$. Then
(A) $BD = CD$ (B) $BA > BD$ (C) $BD > BA$ (D) $CD > CA$
7. It is given that $\triangle ABC \cong \triangle FDE$ and $AB = 5$ cm, $\angle B = 40^\circ$ and $\angle A = 80^\circ$. Then which of the following is true?
(A) $DF = 5$ cm, $\angle F = 60^\circ$ (B) $DF = 5$ cm, $\angle E = 60^\circ$
(C) $DE = 5$ cm, $\angle E = 60^\circ$ (D) $DE = 5$ cm, $\angle D = 40^\circ$
8. Two sides of a triangle are of lengths 5 cm and 1.5 cm. The length of the third side of the triangle cannot be
(A) 3.6 cm (B) 4.1 cm (C) 3.8 cm (D) 3.4 cm
9. In $\triangle PQR$, if $\angle R > \angle Q$, then
(A) $QR > PR$ (B) $PQ > PR$ (C) $PQ < PR$ (D) $QR < PR$
10. In triangles ABC and PQR, $AB = AC$, $\angle C = \angle P$ and $\angle B = \angle Q$. The two triangles are
(A) isosceles but not congruent (B) isosceles and congruent
(C) congruent but not isosceles (D) neither congruent nor isosceles
11. In triangles ABC and DEF, $AB = FD$ and $\angle A = \angle D$. The two triangles will be congruent by SAS axiom if
(A) $BC = EF$ (B) $AC = DE$ (C) $AC = EF$ (D) $BC = DE$

(C) Short Answer Questions with Reasoning

Sample Question 1: In the two triangles ABC and DEF, $AB = DE$ and $AC = EF$. Name two angles from the two triangles that must be equal so that the two triangles are congruent. Give reason for your answer.

Solution: The required two angles are $\angle A$ and $\angle E$. When $\angle A = \angle E$, $\Delta ABC \cong \Delta EDF$ by SAS criterion.

Sample Question 2: In triangles ABC and DEF, $\angle A = \angle D$, $\angle B = \angle E$ and $AB = EF$. Will the two triangles be congruent? Give reasons for your answer.

Solution: Two triangles need not be congruent, because AB and EF are not corresponding sides in the two triangles.

EXERCISE 7.2

1. In triangles ABC and PQR, $\angle A = \angle Q$ and $\angle B = \angle R$. Which side of ΔPQR should be equal to side AB of ΔABC so that the two triangles are congruent? Give reason for your answer.
2. In triangles ABC and PQR, $\angle A = \angle Q$ and $\angle B = \angle R$. Which side of ΔPQR should be equal to side BC of ΔABC so that the two triangles are congruent? Give reason for your answer.
3. "If two sides and an angle of one triangle are equal to two sides and an angle of another triangle, then the two triangles must be congruent." Is the statement true? Why?
4. "If two angles and a side of one triangle are equal to two angles and a side of another triangle, then the two triangles must be congruent." Is the statement true? Why?
5. Is it possible to construct a triangle with lengths of its sides as 4 cm, 3 cm and 7 cm? Give reason for your answer.
6. It is given that $\Delta ABC \cong \Delta RPQ$. Is it true to say that $BC = QR$? Why?
7. If $\Delta PQR \cong \Delta EDF$, then is it true to say that $PR = EF$? Give reason for your answer.
8. In ΔPQR , $\angle P = 70^\circ$ and $\angle R = 30^\circ$. Which side of this triangle is the longest? Give reason for your answer.
9. AD is a median of the triangle ABC. Is it true that $AB + BC + CA > 2 AD$? Give reason for your answer.
10. M is a point on side BC of a triangle ABC such that AM is the bisector of $\angle BAC$. Is it true to say that perimeter of the triangle is greater than 2 AM? Give reason for your answer.

11. Is it possible to construct a triangle with lengths of its sides as 9 cm, 7 cm and 17 cm? Give reason for your answer.
12. Is it possible to construct a triangle with lengths of its sides as 8 cm, 7 cm and 4 cm? Give reason for your answer.

(D) Short Answer Questions

Sample Question 1 : In Fig 7.1, $PQ = PR$ and $\angle Q = \angle R$. Prove that $\Delta PQS \cong \Delta PRT$.

Solution : In ΔPQS and ΔPRT ,

$$PQ = PR \quad (\text{Given})$$

$$\angle Q = \angle R \quad (\text{Given})$$

and $\angle QPS = \angle RPT$ (Same angle)

Therefore, $\Delta PQS \cong \Delta PRT$ (ASA)

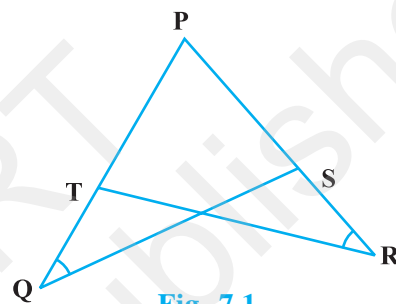

Fig. 7.1

Sample Question 2 : In Fig.7.2, two lines AB and CD intersect each other at the point O such that $BC \parallel DA$ and $BC = DA$. Show that O is the mid-point of both the line-segments AB and CD.

Solution : $BC \parallel AD$ (Given)

Therefore, $\angle CBO = \angle DAO$ (Alternate interior angles)

and $\angle BCO = \angle ADO$ (Alternate interior angles)

Also, $BC = DA$ (Given)

So, $\Delta BOC \cong \Delta AOD$ (ASA)

Therefore, $OB = OA$ and $OC = OD$, i.e., O is the mid-point of both AB and CD.

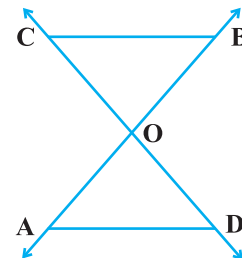

Fig. 7.2

Sample Question 3 : In Fig.7.3, $PQ > PR$ and QS and RS are the bisectors of $\angle Q$ and $\angle R$, respectively. Show that $SQ > SR$.

Solution : $PQ > PR$ (Given)

Therefore, $\angle R > \angle Q$ (Angles opposite the longer side is greater)

So, $\angle SRQ > \angle SQR$ (Half of each angle)

Therefore, $SQ > SR$ (Side opposite the greater angle will be longer)

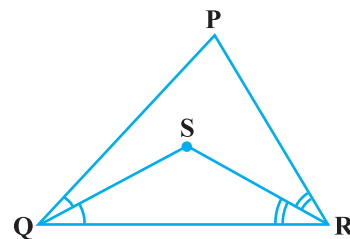

Fig. 7.3

EXERCISE 7.3

1. ABC is an isosceles triangle with $AB = AC$ and BD and CE are its two medians. Show that $BD = CE$.
2. In Fig.7.4, D and E are points on side BC of a ΔABC such that $BD = CE$ and $AD = AE$. Show that $\Delta ABD \cong \Delta ACE$.
3. CDE is an equilateral triangle formed on a side CD of a square $ABCD$ (Fig.7.5). Show that $\Delta ADE \cong \Delta BCE$.

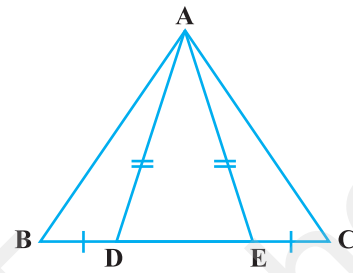

Fig. 7.4

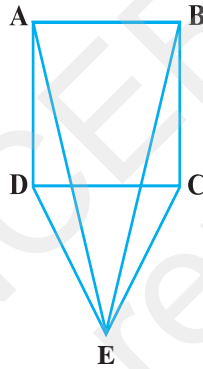

Fig. 7.5

4. In Fig.7.6, $BA \perp AC$, $DE \perp DF$ such that $BA = DE$ and $BF = EC$. Show that $\Delta ABC \cong \Delta DEF$.
5. Q is a point on the side SR of a ΔPSR such that $PQ = PR$. Prove that $PS > PQ$.
6. S is any point on side QR of a ΔPQR . Show that: $PQ + QR + RP > 2 PS$.
7. D is any point on side AC of a ΔABC with $AB = AC$. Show that $CD < BD$.
8. In Fig. 7.7, $l \parallel m$ and M is the mid-point of a line segment AB . Show that M is also the mid-point of any line segment CD , having its end points on l and m , respectively.
9. Bisectors of the angles B and C of an isosceles triangle with $AB = AC$ intersect each other at O . BO is produced to a point M . Prove that $\angle MOC = \angle ABC$.

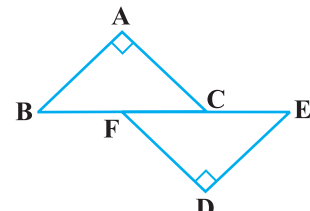

Fig. 7.6

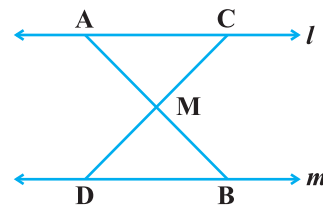

Fig. 7.7

10. Bisectors of the angles B and C of an isosceles triangle ABC with $AB = AC$ intersect each other at O. Show that external angle adjacent to $\angle ABC$ is equal to $\angle BOC$.

11. In Fig. 7.8, AD is the bisector of $\angle BAC$. Prove that $AB > BD$.

(E) Long Answer Questions

Sample Question 1: In Fig. 7.9, ABC is a right triangle and right angled at B such that $\angle BCA = 2 \angle BAC$. Show that hypotenuse $AC = 2 BC$.

Solution: Produce CB to a point D such that $BC = BD$ and join AD.

In $\triangle ABC$ and $\triangle ABD$, we have

$$BC = BD \quad (\text{By construction})$$

$$AB = AB \quad (\text{Same side})$$

$$\angle ABC = \angle ABD \quad (\text{Each of } 90^\circ)$$

Therefore, $\triangle ABC \cong \triangle ABD$ (SAS)

$$\text{So, } \left. \begin{array}{l} \angle CAB = \angle DAB \\ AC = AD \end{array} \right\} \text{(CPCT)} \quad (1)$$

$$\text{and } \quad (2)$$

$$\text{Thus, } \angle CAD = \angle CAB + \angle BAD = x + x = 2x \quad [\text{From (1)}] \quad (3)$$

$$\text{and } \angle ACD = \angle ADB = 2x \quad [\text{From (2), } AC = AD] \quad (4)$$

That is, $\triangle ACD$ is an equilateral triangle. [From (3) and (4)]

or $AC = CD$, i.e., $AC = 2 BC$ (Since $BC = BD$)

Sample Question 2: Prove that if in two triangles two angles and the included side of one triangle are equal to two angles and the included side of the other triangle, then the two triangles are congruent.

Solution: See proof of Theorem 7.1 of Class IX Mathematics Textbook.

Sample Question 3: If the bisector of an angle of a triangle also bisects the opposite side, prove that the triangle is isosceles.

Solution: We are given a point D on side BC of a $\triangle ABC$ such that $\angle BAD = \angle CAD$ and $BD = CD$ (see Fig. 7.10). We are to prove that $AB = AC$.

Produce AD to a point E such that $AD = DE$ and then join CE.

Now, in $\triangle ABD$ and $\triangle ECD$, we have

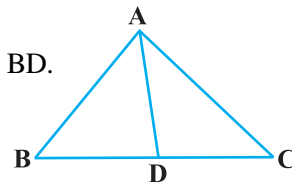

Fig. 7.8

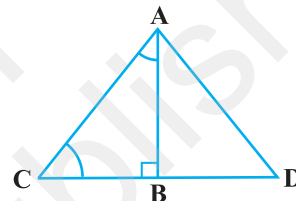

Fig. 7.9

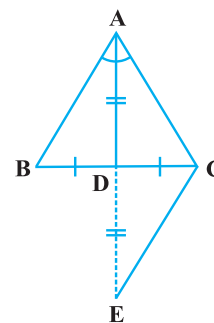

Fig. 7.10

$BD = CD$ (Given)

$AD = ED$ (By construction)

and $\angle ADB = \angle EDC$ (Vertically opposite angles)

Therefore, $\triangle ABD \cong \triangle ECD$ (SAS)

So, $AB = EC$ (1)

and $\angle BAD = \angle CED$ (CPCT) (2)

Also, $\angle BAD = \angle CAD$ (Given)

Therefore, $\angle CAD = \angle CED$ [From (2)]

So, $AC = EC$ [Sides opposite the equal angles] (3)

Therefore, $AB = AC$ [From (1) and (3)]

Sample Question 4 : S is any point in the interior of $\triangle PQR$. Show that $SQ + SR < PQ + PR$.

Solution : Produce QS to intersect PR at T (See Fig. 7.11).

From $\triangle PQT$, we have

$PQ + PT > QT$ (Sum of any two sides is greater than the third side)

i.e., $PQ + PT > SQ + ST$ (1)

From $\triangle TSR$, we have

$ST + TR > SR$ (2)

Adding (1) and (2), we get

$PQ + PT + ST + TR > SQ + ST + SR$

i.e., $PQ + PT + TR > SQ + SR$

i.e., $PQ + PR > SQ + SR$

or $SQ + SR < PQ + PR$

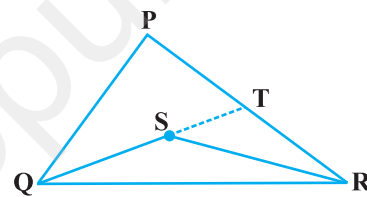

Fig. 7.11

EXERCISE 7.4

1. Find all the angles of an equilateral triangle.
2. The image of an object placed at a point A before a plane mirror LM is seen at the point B by an observer at D as shown in Fig. 7.12. Prove that the image is as far behind the mirror as the object is in front of the mirror.

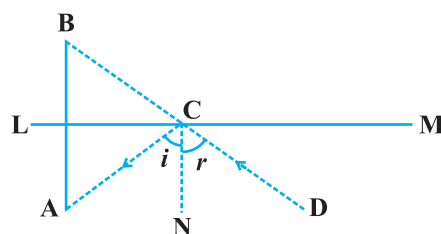

Fig. 7.12

[Hint: CN is normal to the mirror. Also, angle of incidence = angle of reflection].

3. ABC is an isosceles triangle with $AB = AC$ and D is a point on BC such that $AD \perp BC$ (Fig. 7.13). To prove that $\angle BAD = \angle CAD$, a student proceeded as follows:

In $\triangle ABD$ and $\triangle ACD$,

$$AB = AC \quad (\text{Given})$$

$$\angle B = \angle C \quad (\text{because } AB = AC)$$

and $\angle ADB = \angle ADC$

Therefore, $\triangle ABD \cong \triangle ACD$ (AAS)

So, $\angle BAD = \angle CAD$ (CPCT)

What is the defect in the above arguments?

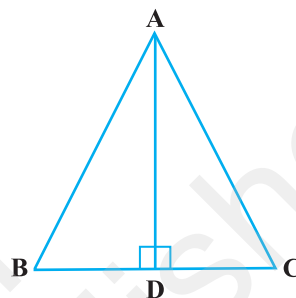

Fig. 7.13

[Hint: Recall how $\angle B = \angle C$ is proved when $AB = AC$].

4. P is a point on the bisector of $\angle ABC$. If the line through P, parallel to BA meet BC at Q, prove that BPQ is an isosceles triangle.
5. ABCD is a quadrilateral in which $AB = BC$ and $AD = CD$. Show that BD bisects both the angles ABC and ADC.
6. ABC is a right triangle with $AB = AC$. Bisector of $\angle A$ meets BC at D. Prove that $BC = 2 AD$.
7. O is a point in the interior of a square ABCD such that OAB is an equilateral triangle. Show that $\triangle OCD$ is an isosceles triangle.
8. ABC and DBC are two triangles on the same base BC such that A and D lie on the opposite sides of BC, $AB = AC$ and $DB = DC$. Show that AD is the perpendicular bisector of BC.
9. ABC is an isosceles triangle in which $AC = BC$. AD and BE are respectively two altitudes to sides BC and AC. Prove that $AE = BD$.
10. Prove that sum of any two sides of a triangle is greater than twice the median with respect to the third side.
11. Show that in a quadrilateral ABCD, $AB + BC + CD + DA < 2 (BD + AC)$
12. Show that in a quadrilateral ABCD,
 $AB + BC + CD + DA > AC + BD$
13. In a triangle ABC, D is the mid-point of side AC such that $BD = \frac{1}{2} AC$. Show that $\angle ABC$ is a right angle.
14. In a right triangle, prove that the line-segment joining the mid-point of the hypotenuse to the opposite vertex is half the hypotenuse.

15. Two lines l and m intersect at the point O and P is a point on a line n passing through the point O such that P is equidistant from l and m . Prove that n is the bisector of the angle formed by l and m .
16. Line segment joining the mid-points M and N of parallel sides AB and DC , respectively of a trapezium $ABCD$ is perpendicular to both the sides AB and DC . Prove that $AD = BC$.
17. $ABCD$ is a quadrilateral such that diagonal AC bisects the angles A and C . Prove that $AB = AD$ and $CB = CD$.
18. ABC is a right triangle such that $AB = AC$ and bisector of angle C intersects the side AB at D . Prove that $AC + AD = BC$.
19. AB and CD are the smallest and largest sides of a quadrilateral $ABCD$. Out of $\angle B$ and $\angle D$ decide which is greater.
20. Prove that in a triangle, other than an equilateral triangle, angle opposite the longest side is greater than $\frac{2}{3}$ of a right angle.
21. $ABCD$ is quadrilateral such that $AB = AD$ and $CB = CD$. Prove that AC is the perpendicular bisector of BD .

QUADRILATERALS

(A) Main Concepts and Results

Sides, Angles and diagonals of a quadrilateral; Different types of quadrilaterals: Trapezium, parallelogram, rectangle, rhombus and square.

- Sum of the angles of a quadrilateral is 360° ,
- A diagonal of a parallelogram divides it into two congruent triangles,
- In a parallelogram
 - (i) opposite angles are equal
 - (ii) opposite sides are equal
 - (iii) diagonals bisect each other.
- A quadrilateral is a parallelogram, if
 - (i) its opposite angles are equal
 - (ii) its opposite sides are equal
 - (iii) its diagonals bisect each other
 - (iv) a pair of opposite sides is equal and parallel.
- Diagonals of a rectangle bisect each other and are equal and vice-versa
- Diagonals of a rhombus bisect each other at right angles and vice-versa
- Diagonals of a square bisect each other at right angles and are equal and vice-versa
- The line-segment joining the mid-points of any two sides of a triangle is parallel to the third side and is half of it.

- A line drawn through the mid-point of a side of a triangle parallel to another side bisects the third side,
- The quadrilateral formed by joining the mid-points of the sides of a quadrilateral, taken in order, is a parallelogram.

(B) Multiple Choice Questions

Write the correct answer :

Sample Question 1 : Diagonals of a parallelogram ABCD intersect at O. If $\angle BOC = 90^\circ$ and $\angle BDC = 50^\circ$, then $\angle OAB$ is

- (A) 90° (B) 50° (C) 40° (D) 10°

Solution : Answer (C)

EXERCISE 8.1

Write the correct answer in each of the following:

1. Three angles of a quadrilateral are 75° , 90° and 75° . The fourth angle is
(A) 90° (B) 95° (C) 105° (D) 120°
2. A diagonal of a rectangle is inclined to one side of the rectangle at 25° . The acute angle between the diagonals is
(A) 55° (B) 50° (C) 40° (D) 25°
3. ABCD is a rhombus such that $\angle ACB = 40^\circ$. Then $\angle ADB$ is
(A) 40° (B) 45° (C) 50° (D) 60°
4. The quadrilateral formed by joining the mid-points of the sides of a quadrilateral PQRS, taken in order, is a rectangle, if
(A) PQRS is a rectangle
(B) PQRS is a parallelogram
(C) diagonals of PQRS are perpendicular
(D) diagonals of PQRS are equal.
5. The quadrilateral formed by joining the mid-points of the sides of a quadrilateral PQRS, taken in order, is a rhombus, if
(A) PQRS is a rhombus
(B) PQRS is a parallelogram
(C) diagonals of PQRS are perpendicular
(D) diagonals of PQRS are equal.

6. If angles A, B, C and D of the quadrilateral ABCD, taken in order, are in the ratio 3:7:6:4, then ABCD is a
- (A) rhombus (B) parallelogram
(C) trapezium (D) kite
7. If bisectors of $\angle A$ and $\angle B$ of a quadrilateral ABCD intersect each other at P, of $\angle B$ and $\angle C$ at Q, of $\angle C$ and $\angle D$ at R and of $\angle D$ and $\angle A$ at S, then PQRS is a
- (A) rectangle (B) rhombus (C) parallelogram
(D) quadrilateral whose opposite angles are supplementary
8. If APB and CQD are two parallel lines, then the bisectors of the angles APQ, BPQ, CQP and PQD form
- (A) a square (B) a rhombus
(C) a rectangle (D) any other parallelogram
9. The figure obtained by joining the mid-points of the sides of a rhombus, taken in order, is
- (A) a rhombus (B) a rectangle
(C) a square (D) any parallelogram
10. D and E are the mid-points of the sides AB and AC of $\triangle ABC$ and O is any point on side BC. O is joined to A. If P and Q are the mid-points of OB and OC respectively, then DEQP is
- (A) a square (B) a rectangle
(C) a rhombus (D) a parallelogram
11. The figure formed by joining the mid-points of the sides of a quadrilateral ABCD, taken in order, is a square only if,
- (A) ABCD is a rhombus
(B) diagonals of ABCD are equal
(C) diagonals of ABCD are equal and perpendicular
(D) diagonals of ABCD are perpendicular.
12. The diagonals AC and BD of a parallelogram ABCD intersect each other at the point O. If $\angle DAC = 32^\circ$ and $\angle AOB = 70^\circ$, then $\angle DBC$ is equal to
- (A) 24° (B) 86° (C) 38° (D) 32°
13. Which of the following is not true for a parallelogram?
- (A) opposite sides are equal
(B) opposite angles are equal
(C) opposite angles are bisected by the diagonals
(D) diagonals bisect each other.

14. D and E are the mid-points of the sides AB and AC respectively of $\triangle ABC$. DE is produced to F. To prove that CF is equal and parallel to DA, we need an additional information which is

- (A) $\angle DAE = \angle EFC$
- (B) $AE = EF$
- (C) $DE = EF$
- (D) $\angle ADE = \angle ECF$.

(C) Short Answer Questions with Reasoning

Sample Question 1 : ABCD is a parallelogram. If its diagonals are equal, then find the value of $\angle ABC$.

Solution : As diagonals of the parallelogram ABCD are equal, it is a rectangle.

Therefore, $\angle ABC = 90^\circ$

Sample Question 2 : Diagonals of a rhombus are equal and perpendicular to each other. Is this statement true? Give reason for your answer.

Solution : This statement is false, because diagonals of a rhombus are perpendicular but not equal to each other.

Sample Question 3 : Three angles of a quadrilateral ABCD are equal. Is it a parallelogram? Why or why not?

Solution: It need not be a parallelogram, because we may have $\angle A = \angle B = \angle C = 80^\circ$ and $\angle D = 120^\circ$. Here, $\angle B \neq \angle D$.

Sample Question 4 : Diagonals AC and BD of a quadrilateral ABCD intersect each other at O such that $OA : OC = 3 : 2$. Is ABCD a parallelogram? Why or why not?

Solution : ABCD is not a parallelogram, because diagonals of a parallelogram bisect each other. Here $OA \neq OC$.

EXERCISE 8.2

1. Diagonals AC and BD of a parallelogram ABCD intersect each other at O. If $OA = 3$ cm and $OD = 2$ cm, determine the lengths of AC and BD.
2. Diagonals of a parallelogram are perpendicular to each other. Is this statement true? Give reason for your answer.
3. Can the angles $110^\circ, 80^\circ, 70^\circ$ and 95° be the angles of a quadrilateral? Why or why not?

4. In quadrilateral ABCD, $\angle A + \angle D = 180^\circ$. What special name can be given to this quadrilateral?
5. All the angles of a quadrilateral are equal. What special name is given to this quadrilateral?
6. Diagonals of a rectangle are equal and perpendicular. Is this statement true? Give reason for your answer.
7. Can all the four angles of a quadrilateral be obtuse angles? Give reason for your answer.
8. In $\triangle ABC$, $AB = 5$ cm, $BC = 8$ cm and $CA = 7$ cm. If D and E are respectively the mid-points of AB and BC, determine the length of DE.
9. In Fig.8.1, it is given that BDEF and FDCE are parallelograms. Can you say that $BD = CD$? Why or why not?

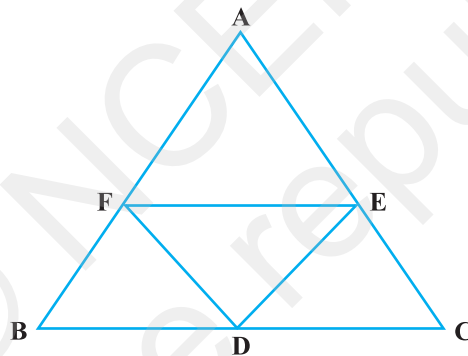

Fig. 8.1

10. In Fig.8.2, ABCD and AEF are two parallelograms. If $\angle C = 55^\circ$, determine $\angle F$.
11. Can all the angles of a quadrilateral be acute angles? Give reason for your answer.
12. Can all the angles of a quadrilateral be right angles? Give reason for your answer.
13. Diagonals of a quadrilateral ABCD bisect each other. If $\angle A = 35^\circ$, determine $\angle B$.

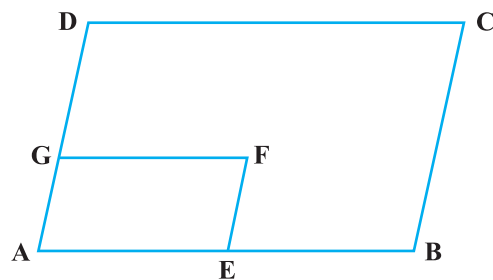

Fig. 8.2

14. Opposite angles of a quadrilateral ABCD are equal. If $AB = 4$ cm, determine CD.

(D) Short Answer Questions

Sample Question 1 : Angles of a quadrilateral are in the ratio 3 : 4 : 4 : 7. Find all the angles of the quadrilateral.

Solution : Let the angles of the quadrilateral be $3x, 4x, 4x$ and $7x$.

So, $3x + 4x + 4x + 7x = 360^\circ$

or $18x = 360^\circ$, i.e., $x = 20^\circ$

Thus, required angles are $60^\circ, 80^\circ, 80^\circ$ and 140° .

Sample Question 2 : In Fig.8.3, X and Y are respectively the mid-points of the opposite sides AD and BC of a parallelogram ABCD. Also, BX and DY intersect AC at P and Q, respectively. Show that $AP = PQ = QC$.

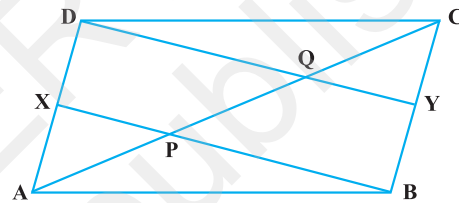

Fig. 8.3

Solution : $AD = BC$
(Opposite sides of a parallelogram)

Therefore, $DX = BY \left(\frac{1}{2} AD \right)$
 $= \frac{1}{2} BC$

Also, $DX \parallel BY$ (As $AD \parallel BC$)

So, XBYD is a parallelogram (A pair of opposite sides equal and parallel)

i.e., $PX \parallel QD$

Therefore, $AP = PQ$ (From $\triangle AQP$ where X is mid-point of AD)

Similarly, from $\triangle CPB$, $CQ = PQ$ (1)

Thus, $AP = PQ = CQ$ [From (1) and (2)] (2)

Sample Question 3 : In Fig.8.4, AX and CY are respectively the bisectors of the opposite angles A and C of a parallelogram ABCD.

Show that $AX \parallel CY$.

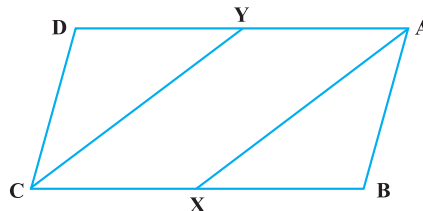

Fig. 8.4

Solution : $\angle A = \angle C$

(Opposite angles of parallelogram ABCD)

Therefore, $\frac{1}{2} \angle A = \frac{1}{2} \angle C$

i.e., $\angle YAX = \angle YCX$

(1)

Also, $\angle AYC + \angle YCX = 180^\circ$ (Because $YA \parallel CX$) (2)

Therefore, $\angle AYC + \angle YAX = 180^\circ$ [From (1) and (2)]

So, $AX \parallel CY$ (As interior angles on the same side of the transversal are supplementary)

EXERCISE 8.3

- One angle of a quadrilateral is of 108° and the remaining three angles are equal. Find each of the three equal angles.
- ABCD is a trapezium in which $AB \parallel DC$ and $\angle A = \angle B = 45^\circ$. Find angles C and D of the trapezium.
- The angle between two altitudes of a parallelogram through the vertex of an obtuse angle of the parallelogram is 60° . Find the angles of the parallelogram.
- ABCD is a rhombus in which altitude from D to side AB bisects AB. Find the angles of the rhombus.
- E and F are points on diagonal AC of a parallelogram ABCD such that $AE = CF$. Show that BFDE is a parallelogram.
- E is the mid-point of the side AD of the trapezium ABCD with $AB \parallel DC$. A line through E drawn parallel to AB intersect BC at F. Show that F is the mid-point of BC. [**Hint:** Join AC]
- Through A, B and C, lines RQ, PR and QP have been drawn, respectively parallel to sides BC, CA and AB of a ΔABC as shown in Fig.8.5. Show that $BC = \frac{1}{2} QR$.
- D, E and F are the mid-points of the sides BC, CA and AB, respectively of an

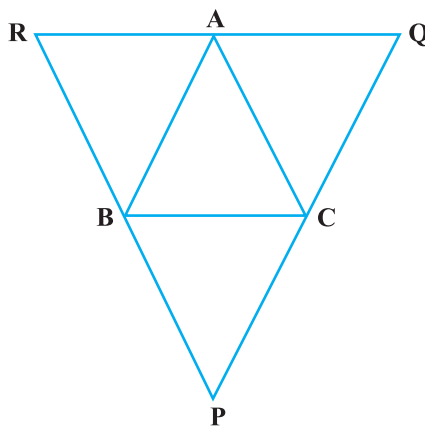

Fig. 8.5

equilateral triangle ABC. Show that ΔDEF is also an equilateral triangle.

9. Points P and Q have been taken on opposite sides AB and CD, respectively of a parallelogram ABCD such that $AP = CQ$ (Fig. 8.6). Show that AC and PQ bisect each other.

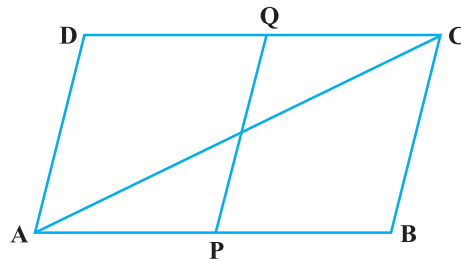

Fig. 8.6

10. In Fig. 8.7, P is the mid-point of side BC of a parallelogram ABCD such that $\angle BAP = \angle DAP$. Prove that $AD = 2CD$.

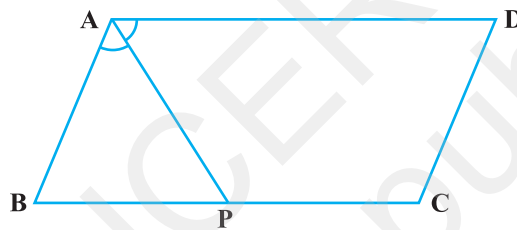

Fig. 8.7

(E) Long Answer Questions

Sample Question 1 : PQ and RS are two equal and parallel line-segments. Any point M not lying on PQ or RS is joined to Q and S and lines through P parallel to QM and through R parallel to SM meet at N. Prove that line segments MN and PQ are equal and parallel to each other.

Solution : We draw the figure as per the given conditions (Fig.8.8).

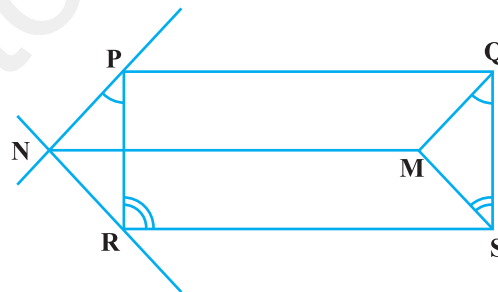

Fig. 8.8

It is given that $PQ = RS$ and $PQ \parallel RS$. Therefore, PQSR is a parallelogram.

So, $PR = QS$ and $PR \parallel QS$ (1)

Now, $PR \parallel QS$

Therefore, $\angle RPQ + \angle PQS = 180^\circ$

(Interior angles on the same side of the transversal)

i.e., $\angle RPQ + \angle PQM + \angle MQS = 180^\circ$ (2)

Also, $PN \parallel QM$ (By construction)

Therefore, $\angle NPQ + \angle PQM = 180^\circ$

i.e., $\angle NPR + \angle RPQ + \angle PQM = 180^\circ$ (3)

So, $\angle NPR = \angle MQS$ [From (2) and (3)] (4)

Similarly, $\angle NRP = \angle MSQ$ (5)

Therefore, $\triangle PNR \cong \triangle QMS$ [ASA, using (1), (4) and (5)]

So, $PN = QM$ and $NR = MS$ (CPCT)

As, $PN = QM$ and

$PN \parallel QM$, we have PQMN is a parallelogram

So, $MN = PQ$ and $NM \parallel PQ$.

Sample Question 2 : Prove that a diagonal of a parallelogram divides it into two congruent triangles.

Solution : See proof of Theorem 8.1 in the textbook.

Sample Question 3 : Show that the quadrilateral formed by joining the mid-points the sides of a rhombus, taken in order, form a rectangle.

Solution : Let ABCD be a rhombus and P, Q, R and S be the mid-points of sides AB, BC, CD and DA, respectively (Fig. 8.9). Join AC and BD.

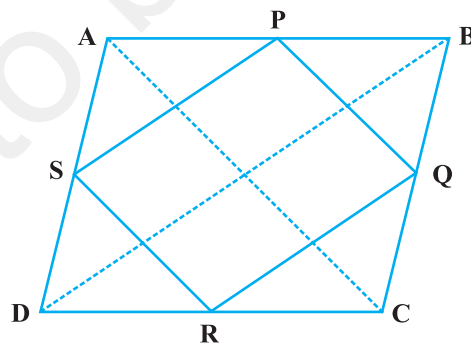

Fig. 8.9

From triangle ABD, we have

$$SP = \frac{1}{2} BD \text{ and}$$

$$SP \parallel BD \text{ (Because S and P are mid-points)}$$

Similarly,

$$RQ = \frac{1}{2} BD \text{ and } RQ \parallel BD$$

Therefore,

$$SP = RQ \text{ and } SP \parallel RQ$$

So, PQRS is a parallelogram. (1)

Also, $AC \perp BD$ (Diagonals of a rhombus are perpendicular)

Further

$$PQ \parallel AC \text{ (From } \triangle BAC)$$

As

$$SP \parallel BD, PQ \parallel AC \text{ and } AC \perp BD,$$

therefore, we have $SP \perp PQ$, i.e. $\angle SPQ = 90^\circ$. (2)

Therefore, PQRS is a rectangle [From (1) and (2)]

Sample Question 4 : A diagonal of a parallelogram bisects one of its angle. Prove that it will bisect its opposite angle also.

Solution : Let us draw the figure as per given condition (Fig.8.10). In it, AC is a diagonal which bisects $\angle BAD$ of the parallelogram ABCD, i.e., it is given that $\angle BAC = \angle DAC$. We need to prove that $\angle BCA = \angle DCA$.

$AB \parallel CD$ and AC is a transversal.

Therefore, $\angle BAC = \angle DCA$ (Alternate angles) (1)

Similarly, $\angle DAC = \angle BCA$ (From $AD \parallel BC$) (2)

But it is given that $\angle BAC = \angle DAC$ (3)

Therefore, from (1), (2) and (3), we have

$$\angle BCA = \angle DCA$$

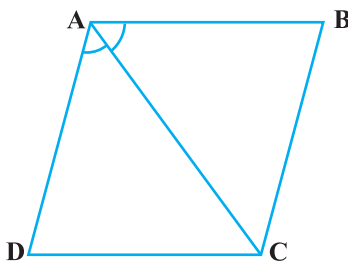

Fig. 8.10

EXERCISE 8.4

1. A square is inscribed in an isosceles right triangle so that the square and the triangle have one angle common. Show that the vertex of the square opposite the vertex of the common angle bisects the hypotenuse.
2. In a parallelogram ABCD, $AB = 10$ cm and $AD = 6$ cm. The bisector of $\angle A$ meets DC in E. AE and BC produced meet at F. Find the length of CF.
3. P, Q, R and S are respectively the mid-points of the sides AB, BC, CD and DA of a quadrilateral ABCD in which $AC = BD$. Prove that PQRS is a rhombus.
4. P, Q, R and S are respectively the mid-points of the sides AB, BC, CD and DA of a quadrilateral ABCD such that $AC \perp BD$. Prove that PQRS is a rectangle.
5. P, Q, R and S are respectively the mid-points of sides AB, BC, CD and DA of quadrilateral ABCD in which $AC = BD$ and $AC \perp BD$. Prove that PQRS is a square.
6. A diagonal of a parallelogram bisects one of its angles. Show that it is a rhombus.
7. P and Q are the mid-points of the opposite sides AB and CD of a parallelogram ABCD. AQ intersects DP at S and BQ intersects CP at R. Show that PRQS is a parallelogram.
8. ABCD is a quadrilateral in which $AB \parallel DC$ and $AD = BC$. Prove that $\angle A = \angle B$ and $\angle C = \angle D$.
9. In Fig. 8.11, $AB \parallel DE$, $AB = DE$, $AC \parallel DF$ and $AC = DF$. Prove that $BC \parallel EF$ and $BC = EF$.

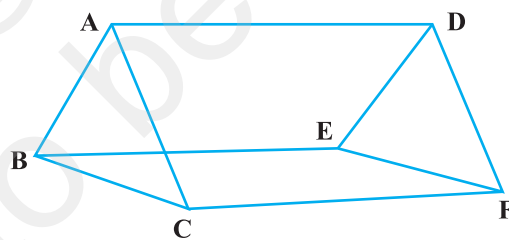

Fig. 8.11

10. E is the mid-point of a median AD of $\triangle ABC$ and BE is produced to meet AC at F. Show that $AF = \frac{1}{3} AC$.
11. Show that the quadrilateral formed by joining the mid-points of the consecutive sides of a square is also a square.

12. E and F are respectively the mid-points of the non-parallel sides AD and BC of a trapezium ABCD. Prove that $EF \parallel AB$ and $EF = \frac{1}{2} (AB + CD)$.
- [Hint: Join BE and produce it to meet CD produced at G]
13. Prove that the quadrilateral formed by the bisectors of the angles of a parallelogram is a rectangle.
14. P and Q are points on opposite sides AD and BC of a parallelogram ABCD such that PQ passes through the point of intersection O of its diagonals AC and BD. Show that PQ is bisected at O.
15. ABCD is a rectangle in which diagonal BD bisects $\angle B$. Show that ABCD is a square.
16. D, E and F are respectively the mid-points of the sides AB, BC and CA of a triangle ABC. Prove that by joining these mid-points D, E and F, the triangle ABC is divided into four congruent triangles.
17. Prove that the line joining the mid-points of the diagonals of a trapezium is parallel to the parallel sides of the trapezium.
18. P is the mid-point of the side CD of a parallelogram ABCD. A line through C parallel to PA intersects AB at Q and DA produced at R. Prove that $DA = AR$ and $CQ = QR$.

AREAS OF PARALLELOGRAMS AND TRIANGLES

(A) Main Concepts and Results

The area of a closed plane figure is the measure of the region inside the figure:

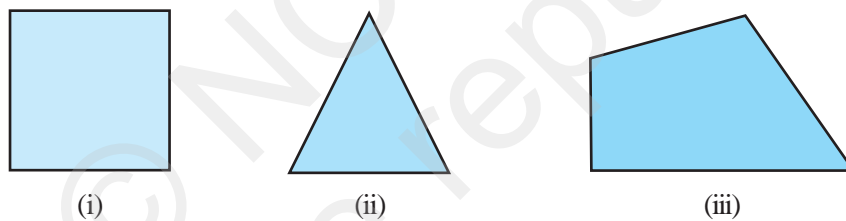

Fig. 9.1

The shaded parts (Fig.9.1) represent the regions whose areas may be determined by means of simple geometrical results. The square unit is the standard unit used in measuring the area of such figures.

- If $\Delta ABC \cong \Delta PQR$, then $\text{ar}(\Delta ABC) = \text{ar}(\Delta PQR)$

Total area R of the plane figure $ABCD$ is the sum of the areas of two triangular regions R_1 and R_2 , that is, $\text{ar}(R) = \text{ar}(R_1) + \text{ar}(R_2)$

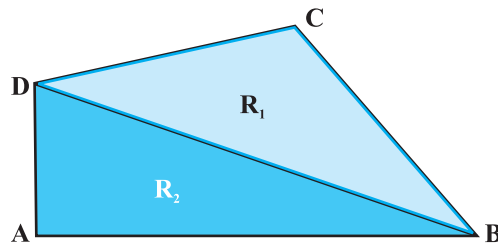

Fig. 9.2

- Two congruent figures have equal areas but the converse is not always true,
- A diagonal of a parallelogram divides the parallelogram in two triangles of equal area,
- (i) Parallelograms on the same base and between the same parallels are equal in area
- (ii) A parallelogram and a rectangle on the same base and between the same parallels are equal in area.
- Parallelograms on equal bases and between the same parallels are equal in area,
- Triangles on the same base and between the same parallels are equal in area,
- Triangles with equal bases and equal areas have equal corresponding altitudes,
- The area of a triangle is equal to one-half of the area of a rectangle/parallelogram of the same base and between same parallels,
- If a triangle and a parallelogram are on the same base and between the same parallels, the area of the triangle is equal to one-half area of the parallelogram.

(B) Multiple Choice Questions

Write the correct answer:

Sample Question 1 : The area of the figure formed by joining the mid-points of the adjacent sides of a rhombus with diagonals 12 cm and 16 cm is

- (A) 48 cm^2 (B) 64 cm^2 (C) 96 cm^2 (D) 192 cm^2

Solution: Answer (A)

EXERCISE 9.1

Write the correct answer in each of the following :

1. The median of a triangle divides it into two

(A) triangles of equal area	(B) congruent triangles
(C) right triangles	(D) isosceles triangles
2. In which of the following figures (Fig. 9.3), you find two polygons on the same base and between the same parallels?

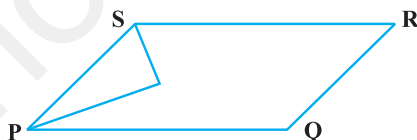

(A)

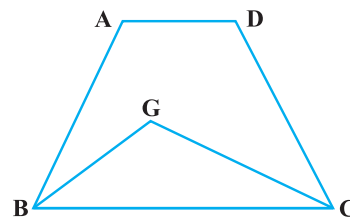

(B)

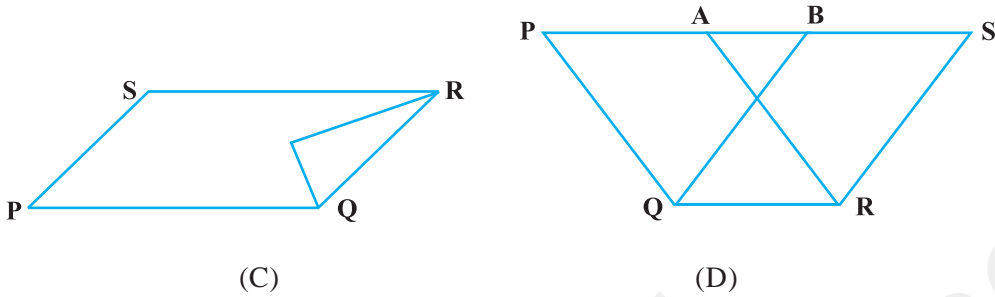

Fig. 9.3

3. The figure obtained by joining the mid-points of the adjacent sides of a rectangle of sides 8 cm and 6 cm is :
- (A) a rectangle of area 24 cm^2 (B) a square of area 25 cm^2
 (C) a trapezium of area 24 cm^2 (D) a rhombus of area 24 cm^2
4. In Fig. 9.4, the area of parallelogram ABCD is :

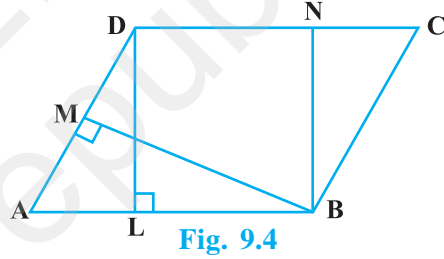

Fig. 9.4

5. In Fig. 9.5, if parallelogram ABCD and rectangle ABEM are of equal area, then :
- (A) Perimeter of ABCD = Perimeter of ABEM
 (B) Perimeter of ABCD < Perimeter of ABEM
 (C) Perimeter of ABCD > Perimeter of ABEM
 (D) Perimeter of ABCD = $\frac{1}{2}$ (Perimeter of ABEM)

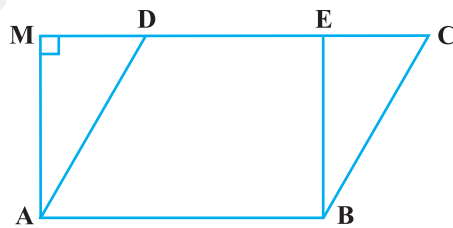

Fig. 9.5

6. The mid-point of the sides of a triangle along with any of the vertices as the fourth point make a parallelogram of area equal to
- (A) $\frac{1}{2}$ ar (ABC) (B) $\frac{1}{3}$ ar (ABC)
- (C) $\frac{1}{4}$ ar (ABC) (D) ar (ABC)
7. Two parallelograms are on equal bases and between the same parallels. The ratio of their areas is
- (A) 1 : 2 (B) 1 : 1 (C) 2 : 1 (D) 3 : 1
8. ABCD is a quadrilateral whose diagonal AC divides it into two parts, equal in area, then ABCD
- (A) is a rectangle (B) is always a rhombus
- (C) is a parallelogram (D) need not be any of (A), (B) or (C)
9. If a triangle and a parallelogram are on the same base and between same parallels, then the ratio of the area of the triangle to the area of parallelogram is
- (A) 1 : 3 (B) 1 : 2 (C) 3 : 1 (D) 1 : 4
10. ABCD is a trapezium with parallel sides $AB = a$ cm and $DC = b$ cm (Fig. 9.6). E and F are the mid-points of the non-parallel sides. The ratio of ar (ABFE) and ar (EFCD) is
- (A) $a : b$
- (B) $(3a + b) : (a + 3b)$
- (C) $(a + 3b) : (3a + b)$
- (D) $(2a + b) : (3a + b)$

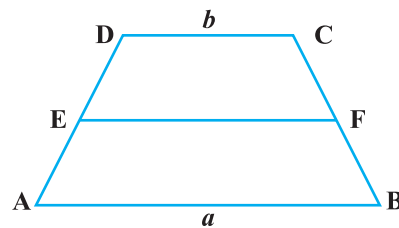

Fig. 9.6

(C) Short Answer Questions with Reasoning

Write **True** or **False** and justify your answer.

Sample Question 1 : If P is any point on the median AD of a ΔABC , then ar (ABP) \neq ar (ACP).

Solution : False, because ar (ABD) = ar (ACD) and ar (PBD) = ar (PCD), therefore, ar (ABP) = ar (ACP).

Sample Question 2 : If in Fig. 9.7, PQRS and EFRS are two parallelograms, then

$$\text{ar (MFR)} = \frac{1}{2} \text{ ar (PQRS)}.$$

Solution : True, because $\text{ar (PQRS)} = \text{ar (EFRS)} = 2 \text{ ar (MFR)}$.

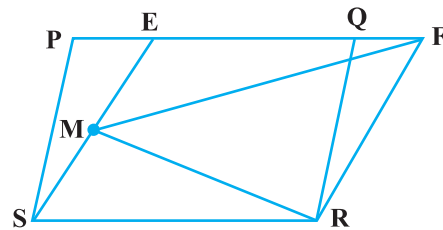

Fig. 9.7

EXERCISE 9.2

Write True or False and justify your answer :

1. ABCD is a parallelogram and X is the mid-point of AB. If $\text{ar (AXCD)} = 24 \text{ cm}^2$, then $\text{ar (ABC)} = 24 \text{ cm}^2$.
2. PQRS is a rectangle inscribed in a quadrant of a circle of radius 13 cm. A is any point on PQ. If $PS = 5 \text{ cm}$, then $\text{ar (PAS)} = 30 \text{ cm}^2$.
3. PQRS is a parallelogram whose area is 180 cm^2 and A is any point on the diagonal QS. The area of $\Delta ASR = 90 \text{ cm}^2$.
4. ABC and BDE are two equilateral triangles such that D is the mid-point of BC.

$$\text{Then ar (BDE)} = \frac{1}{4} \text{ ar (ABC)}.$$

5. In Fig. 9.8, ABCD and EFGD are two parallelograms and G is the mid-point of CD. Then

$$\text{ar (DPC)} = \frac{1}{2} \text{ ar (EFGD)}.$$

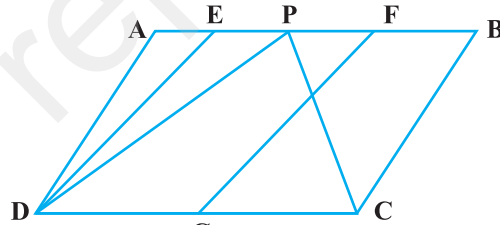

Fig. 9.8

(D) Short Answer Questions

Sample Question 1 : PQRS is a square. T and U are respectively, the mid-points of PS and QR (Fig. 9.9). Find the area of ΔOTS , if $PQ = 8 \text{ cm}$, where O is the point of intersection of TU and QS.

Solution : $PS = PQ = 8 \text{ cm}$ and $TU \parallel PQ$

$$ST = \frac{1}{2} PS = \frac{1}{2} \times 8 = 4 \text{ cm}$$

$$PQ = TU = 8 \text{ cm}$$

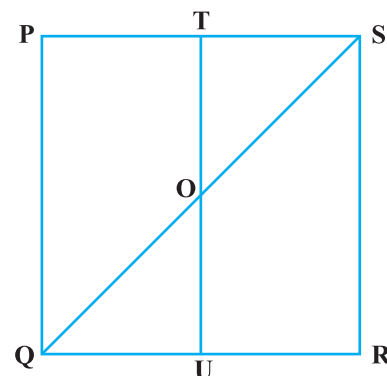

Fig. 9.9

$$OT = \frac{1}{2} TU = \frac{1}{2} \times 8 = 4 \text{ cm}$$

Area of triangle OTS

$$= \frac{1}{2} \times ST \times OT \text{ [Since OTS is a right angled triangle]}$$

$$= \frac{1}{2} \times 4 \times 4 \text{ cm}^2 = 8 \text{ cm}^2$$

Sample Question 2 : ABCD is a parallelogram and BC is produced to a point Q such that AD = CQ (Fig. 9.10). If AQ intersects DC at P, show that ar (BPC) = ar (DPQ)

Solution: ar (ACP) = ar (BCP) (1)

[Triangles on the same base and between same parallels]

ar (ADQ) = ar (ADC) (2)

ar (ADC) – ar (ADP) = ar (ADQ) – ar (ADP)

ar (APC) = ar (DPQ) (3)

From (1) and (3), we get

ar (BCP) = ar (DPQ)

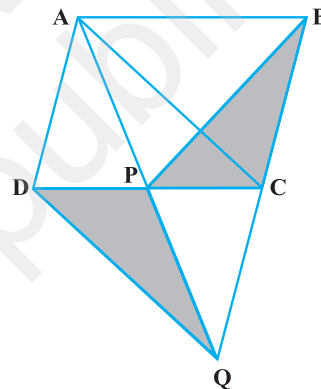

Fig. 9.10

EXERCISE 9.3

- In Fig.9.11, PSDA is a parallelogram. Points Q and R are taken on PS such that PQ = QR = RS and PA || QB || RC. Prove that ar (PQE) = ar (CFD).

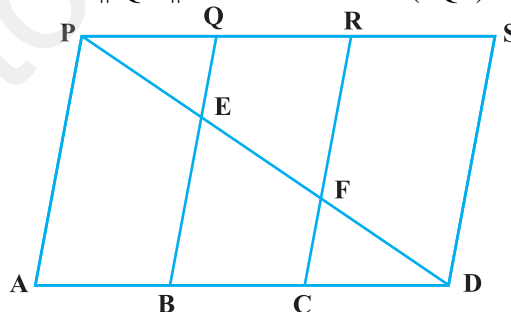

Fig. 9.11

2. X and Y are points on the side LN of the triangle LMN such that $LX = XY = YN$. Through X, a line is drawn parallel to LM to meet MN at Z (See Fig. 9.12). Prove that

$$\text{ar}(\text{LZY}) = \text{ar}(\text{MZYX})$$

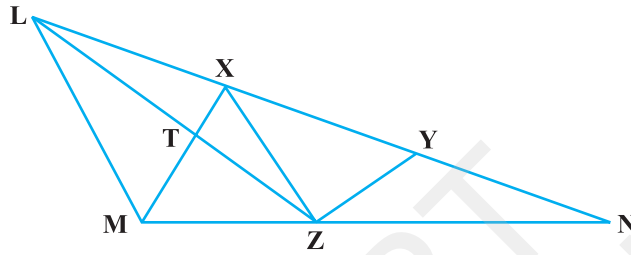

Fig. 9.12

3. The area of the parallelogram ABCD is 90 cm^2 (see Fig.9.13). Find

- (i) $\text{ar}(\text{ABEF})$
- (ii) $\text{ar}(\text{ABD})$
- (iii) $\text{ar}(\text{BEF})$

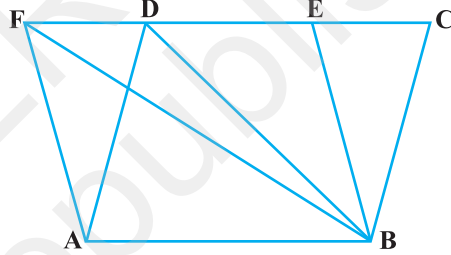

Fig. 9.13

4. In ΔABC , D is the mid-point of AB and P is any point on BC. If $CQ \parallel PD$ meets AB in Q (Fig. 9.14), then prove that

$$\text{ar}(\text{BPQ}) = \frac{1}{2} \text{ar}(\text{ABC}).$$

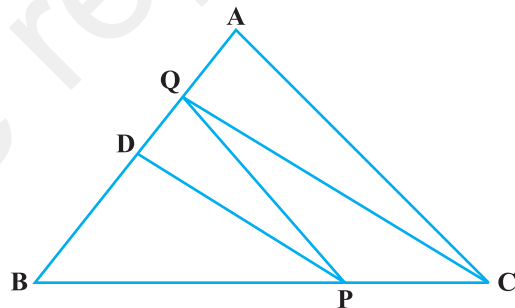

Fig. 9.14

5. ABCD is a square. E and F are respectively the mid-points of BC and CD. If R is the mid-point of EF (Fig. 9.15), prove that

$$\text{ar}(\text{AER}) = \text{ar}(\text{AFR})$$

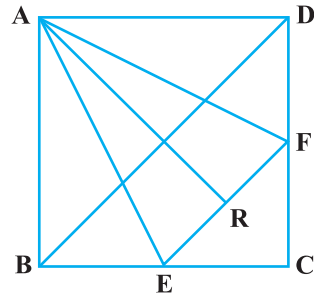

Fig. 9.15

6. O is any point on the diagonal PR of a parallelogram PQRS (Fig. 9.16). Prove that $\text{ar}(\text{PSO}) = \text{ar}(\text{PQO})$.

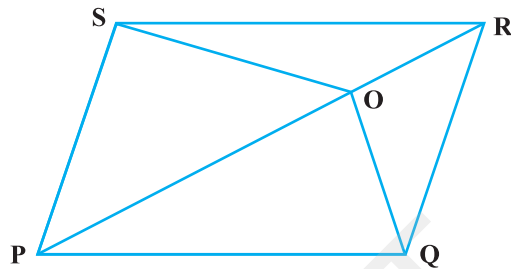

Fig. 9.16

7. ABCD is a parallelogram in which BC is produced to E such that $CE = BC$ (Fig. 9.17). AE intersects CD at F. If $\text{ar}(\text{DFB}) = 3 \text{ cm}^2$, find the area of the parallelogram ABCD.

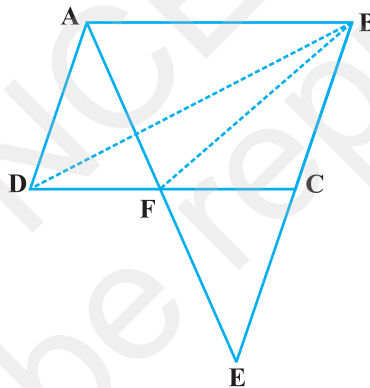

Fig. 9.17

8. In trapezium ABCD, $AB \parallel DC$ and L is the mid-point of BC. Through L, a line PQ $\parallel AD$ has been drawn which meets AB in P and DC produced in Q (Fig. 9.18). Prove that $\text{ar}(\text{ABCD}) = \text{ar}(\text{APQD})$

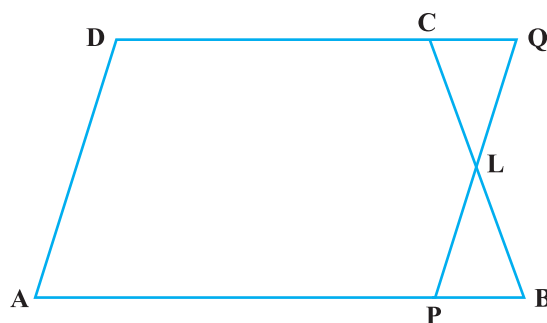

Fig. 9.18

9. If the mid-points of the sides of a quadrilateral are joined in order, prove that the area of the parallelogram so formed will be half of the area of the given quadrilateral (Fig. 9.19).

[Hint: Join BD and draw perpendicular from A on BD.]

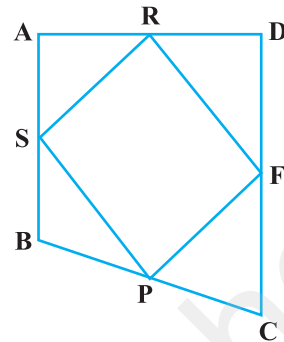

Fig. 9.19

(E) Long Answer Questions

Sample Question 1 : In Fig. 9.20, ABCD is a parallelogram. Points P and Q on BC trisect BC in three equal parts. Prove that

$$\text{ar}(\text{APQ}) = \text{ar}(\text{DPQ}) = \frac{1}{6} \text{ar}(\text{ABCD})$$

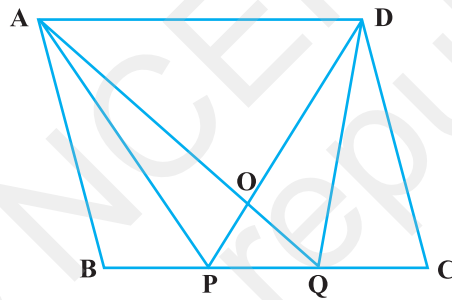

Fig. 9.20

Solution :

Through P and Q, draw PR and QS parallel to AB. Now PQRS is a parallelogram and

its base $PQ = \frac{1}{3} BC$.

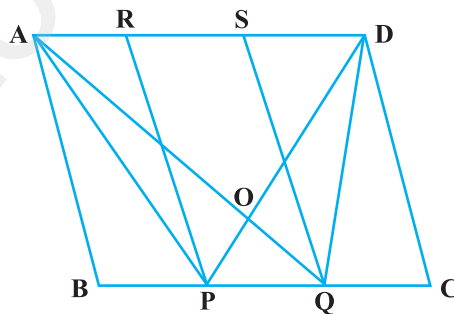

Fig. 9.21

$$\text{ar}(\text{APD}) = \frac{1}{2} \text{ar}(\text{ABCD}) \text{ [Same base BC and BC} \parallel \text{AD]} \quad (1)$$

$$\text{ar}(\text{AQD}) = \frac{1}{2} \text{ar}(\text{ABCD}) \quad (2)$$

From (1) and (2), we get

$$\text{ar}(\text{APD}) = \text{ar}(\text{AQD}) \quad (3)$$

Subtracting ar(AOD) from both sides, we get

$$\text{ar}(\text{APD}) - \text{ar}(\text{AOD}) = \text{ar}(\text{AQD}) - \text{ar}(\text{AOD}) \quad (4)$$

$$\text{ar}(\text{APO}) = \text{ar}(\text{OQD}),$$

Adding ar(OPQ) on both sides in (4), we get

$$\text{ar}(\text{APO}) + \text{ar}(\text{OPQ}) = \text{ar}(\text{OQD}) + \text{ar}(\text{OPQ})$$

$$\text{ar}(\text{APQ}) = \text{ar}(\text{DPQ})$$

Since, $\text{ar}(\text{APQ}) = \frac{1}{2} \text{ar}(\text{PQRS})$, therefore

$$\text{ar}(\text{DPQ}) = \frac{1}{2} \text{ar}(\text{PQRS})$$

$$\text{Now, ar}(\text{PQRS}) = \frac{1}{3} \text{ar}(\text{ABCD})$$

Therefore, $\text{ar}(\text{APQ}) = \text{ar}(\text{DPQ})$

$$= \frac{1}{2} \text{ar}(\text{PQRS}) = \frac{1}{2} \times \frac{1}{3} \text{ar}(\text{ABCD})$$

$$= \frac{1}{6} \text{ar}(\text{ABCD})$$

Sample Question 2 : In Fig. 9.22, l, m, n , are straight lines such that $l \parallel m$ and n intersects l at P and m at Q. ABCD is a quadrilateral such that its vertex A is on l . The vertices C and D are on m and $AD \parallel n$. Show that

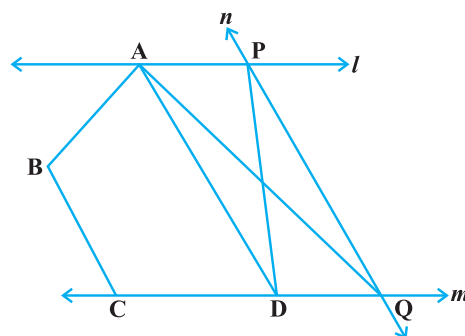

Fig. 9.22

$$\text{ar}(\text{ABCQ}) = \text{ar}(\text{ABCDP})$$

$$\text{Solution : ar}(\text{APD}) = \text{ar}(\text{AQD}) \quad (1)$$

[Have same base AD and also between same parallels AD and n].

Adding ar(ABCD) on both sides in (1), we get

$$\text{ar}(\text{APD}) + \text{ar}(\text{ABCD}) = \text{ar}(\text{AQD}) + \text{ar}(\text{ABCD})$$

$$\text{or ar}(\text{ABCDP}) = \text{ar}(\text{ABCQ})$$

Sample Questions 3 : In Fig. 9.23, $BD \parallel CA$,

E is mid-point of CA and $BD = \frac{1}{2} CA$. Prove

that $\text{ar}(\text{ABC}) = 2\text{ar}(\text{DBC})$

Solution : Join DE. Here BCED is a

parallelogram, since

$BD = CE$ and $BD \parallel CE$

$$\text{ar}(\text{DBC}) = \text{ar}(\text{EBC}) \quad (1)$$

[Have the same base BC and between the same parallels]

In ΔABC , BE is the median,

$$\text{So, ar}(\text{EBC}) = \frac{1}{2} \text{ar}(\text{ABC})$$

$$\text{Now, ar}(\text{ABC}) = \text{ar}(\text{EBC}) + \text{ar}(\text{ABE})$$

$$\text{Also, ar}(\text{ABC}) = 2 \text{ar}(\text{EBC}), \text{ therefore,}$$

$$\text{ar}(\text{ABC}) = 2 \text{ar}(\text{DBC}).$$

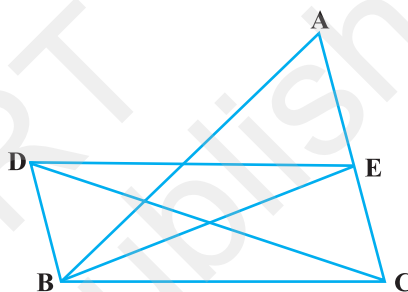

Fig. 9.23

EXERCISE 9.4

1. A point E is taken on the side BC of a parallelogram ABCD. AE and DC are produced to meet at F. Prove that $\text{ar}(\text{ADF}) = \text{ar}(\text{ABFC})$
2. The diagonals of a parallelogram ABCD intersect at a point O. Through O, a line is drawn to intersect AD at P and BC at Q. Show that PQ divides the parallelogram into two parts of equal area.
3. The medians BE and CF of a triangle ABC intersect at G. Prove that the area of $\Delta GBC =$ area of the quadrilateral AFGE.

4. In Fig. 9.24, $CD \parallel AE$ and $CY \parallel BA$. Prove that $\text{ar}(\text{CBX}) = \text{ar}(\text{AXY})$

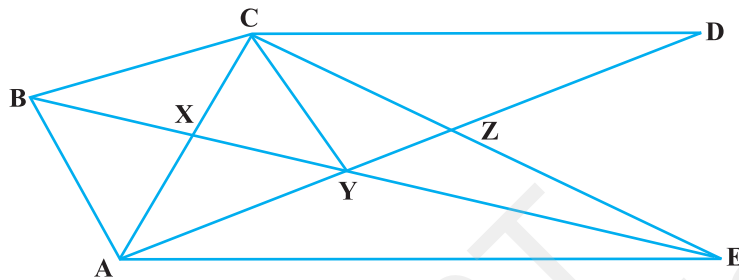

Fig. 9.24

5. ABCD is a trapezium in which $AB \parallel DC$, $DC = 30$ cm and $AB = 50$ cm. If X and Y are, respectively the mid-points of AD and BC, prove that $\text{ar}(\text{DCYX}) = \frac{7}{9} \text{ar}(\text{XYBA})$
6. In ΔABC , if L and M are the points on AB and AC, respectively such that $LM \parallel BC$. Prove that $\text{ar}(\text{LOB}) = \text{ar}(\text{MOC})$
7. In Fig. 9.25, ABCDE is any pentagon. BP drawn parallel to AC meets DC produced at P and EQ drawn parallel to AD meets CD produced at Q. Prove that $\text{ar}(\text{ABCDE}) = \text{ar}(\text{APQ})$

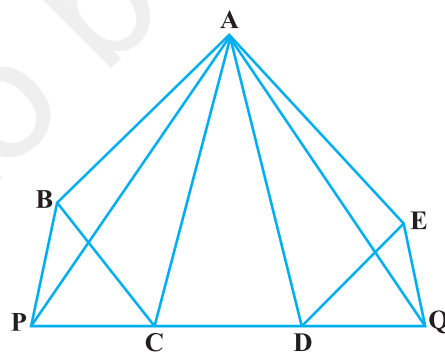

Fig. 9.25

8. If the medians of a ΔABC intersect at G , show that
 $\text{ar}(\text{AGB}) = \text{ar}(\text{AGC}) = \text{ar}(\text{BGC})$
 $= \frac{1}{3} \text{ar}(\text{ABC})$
9. In Fig. 9.26, X and Y are the mid-points of AC and AB respectively, $QP \parallel BC$ and CYQ and BXP are straight lines. Prove that $\text{ar}(\text{ABP}) = \text{ar}(\text{ACQ})$.

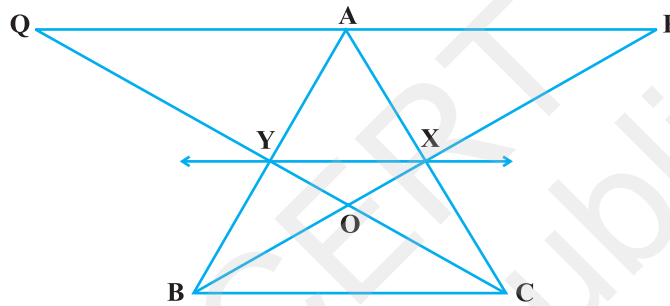

Fig. 9.26

10. In Fig. 9.27, $ABCD$ and $AEFD$ are two parallelograms. Prove that
 $\text{ar}(\text{PEA}) = \text{ar}(\text{QFD})$ [Hint: Join PD].

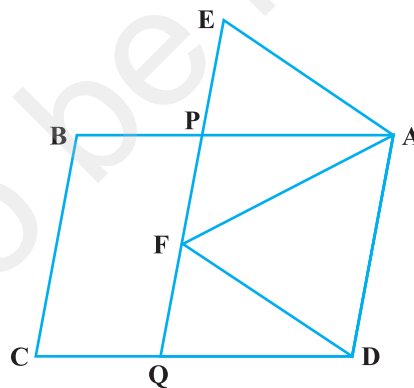

Fig. 9.27

CIRCLES

(A) Main Concepts and Results

Circle, radius, diameter, chord, segment, cyclic quadrilateral.

- Equal chords of a circle (or of congruent circles) subtend equal angles at the centre,
- If the angles subtended by the chords of a circle (or of congruent circles) at the centre (or centres) are equal, then the chords are equal,
- The perpendicular drawn from the centre of the circle to a chord bisects the chord,
- The line drawn through the centre of a circle bisecting a chord is perpendicular to the chord,
- There is one and only one circle passing through three given non-collinear points,
- Equal chords of a circle (or of congruent circles) are equidistant from the centre (or centres),
- Chords equidistant from the centre of a circle are equal in length,
- If two chords of a circle are equal, then their corresponding arcs are congruent and conversely, if two arcs are congruent, then their corresponding chords are equal,
- Congruent arcs of a circle subtend equal angles at the centre,
- The angle subtended by an arc at the centre is double the angle subtended by it at any point on the remaining part of the circle,
- Angles in the same segment of a circle are equal,
- If a line segment joining two points subtends equal angles at two other points lying on the same side of the line containing the line segment, then the four points are concyclic,

- The sum of either pair of opposite angles of a cyclic quadrilateral is 180° ,
- If the sum of a pair of opposite angles of a quadrilateral is 180° , the quadrilateral is cyclic.

(B) Multiple Choice Questions

Write the correct answer :

Sample Question 1: In Fig. 10.1, two congruent circles have centres O and O' . Arc AXB subtends an angle of 75° at the centre O and arc $A'YB'$ subtends an angle of 25° at the centre O' . Then the ratio of arcs AXB and $A'YB'$ is:

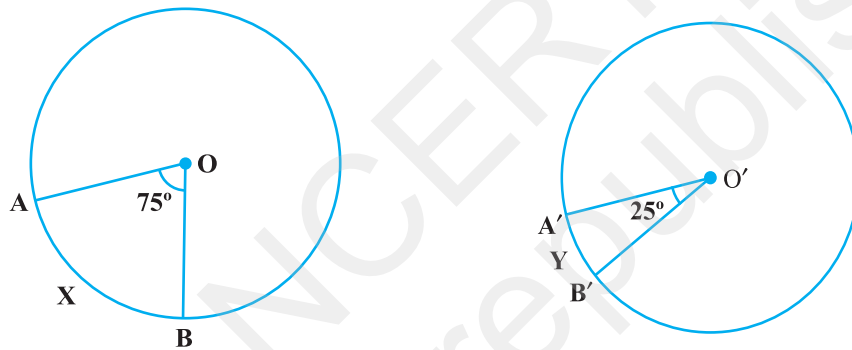

Fig. 10.1

- (A) 2 : 1 (B) 1 : 2 (C) 3 : 1 (D) 1 : 3

Solution : Answer (C)

Sample Question 2 : In Fig. 10.2, AB and CD are two equal chords of a circle with centre O . OP and OQ are perpendiculars on chords AB and CD , respectively. If $\angle POQ = 150^\circ$, then $\angle APQ$ is equal to

- (A) 30° (B) 75°
(C) 15° (D) 60°

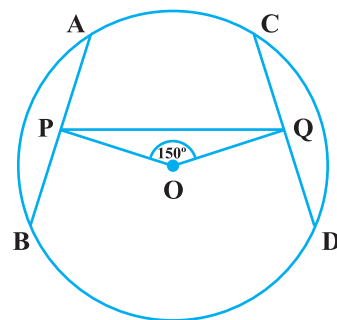
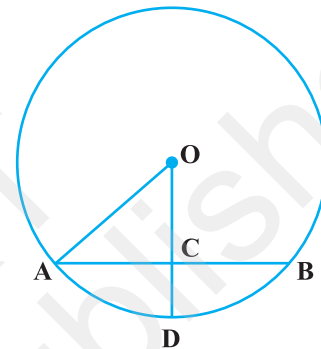
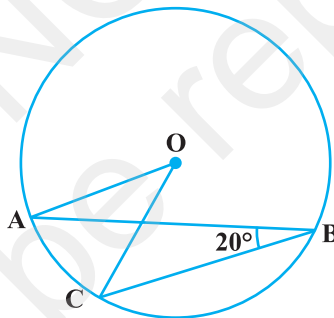

Fig. 10.2

Solution : Answer (B)

EXERCISE 10.1

- AD is a diameter of a circle and AB is a chord. If $AD = 34$ cm, $AB = 30$ cm, the distance of AB from the centre of the circle is :
 (A) 17 cm (B) 15 cm (C) 4 cm (D) 8 cm
- In Fig. 10.3, if $OA = 5$ cm, $AB = 8$ cm and OD is perpendicular to AB, then CD is equal to:
 (A) 2 cm (B) 3 cm
 (C) 4 cm (D) 5 cm
- If $AB = 12$ cm, $BC = 16$ cm and AB is perpendicular to BC, then the radius of the circle passing through the points A, B and C is :
 (A) 6 cm (B) 8 cm
 (C) 10 cm (D) 12 cm
- In Fig.10.4, if $\angle ABC = 20^\circ$, then $\angle AOC$ is equal to:
 (A) 20° (B) 40° (C) 60° (D) 10°

**Fig. 10.3****Fig. 10.4**

- In Fig.10.5, if AOB is a diameter of the circle and $AC = BC$, then $\angle CAB$ is equal to:
 (A) 30° (B) 60°
 (C) 90° (D) 45°

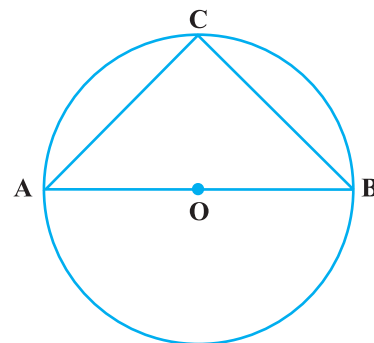
**Fig. 10.5**

6. In Fig. 10.6, if $\angle OAB = 40^\circ$, then $\angle ACB$ is equal to :

(A) 50° (B) 40° (C) 60° (D) 70°

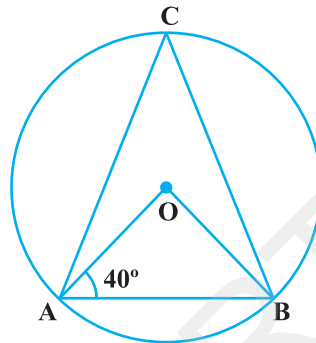

Fig. 10.6

7. In Fig. 10.7, if $\angle DAB = 60^\circ$, $\angle ABD = 50^\circ$, then $\angle ACB$ is equal to:

(A) 60° (B) 50° (C) 70° (D) 80°

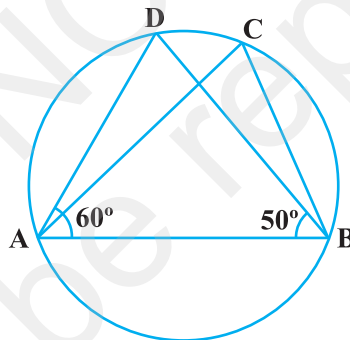

Fig. 10.7

8. ABCD is a cyclic quadrilateral such that AB is a diameter of the circle circumscribing it and $\angle ADC = 140^\circ$, then $\angle BAC$ is equal to:

(A) 80° (B) 50°
(C) 40° (D) 30°

9. In Fig. 10.8, BC is a diameter of the circle and $\angle BAO = 60^\circ$. Then $\angle ADC$ is equal to :

(A) 30° (B) 45°
(C) 60° (D) 120°

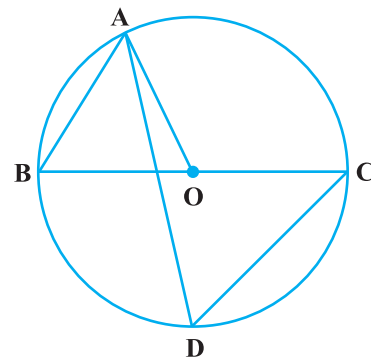

Fig. 10.8

10. In Fig. 10.9, $\angle AOB = 90^\circ$ and $\angle ABC = 30^\circ$, then $\angle CAO$ is equal to:
 (A) 30° (B) 45° (C) 90° (D) 60°

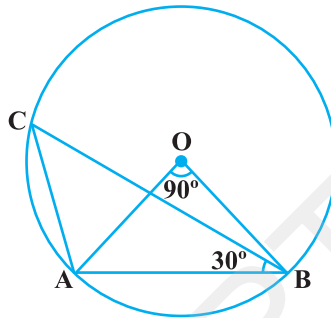

Fig. 10.9

(C) Short Answer Questions with Reasoning

Write **True** or **False** and justify your answer.

Sample Question 1: The angles subtended by a chord at any two points of a circle are equal.

Solution : False. If two points lie in the same segment (major or minor) only, then the angles will be equal otherwise they are not equal.

Sample Questions 2 : Two chords of a circle of lengths 10 cm and 8 cm are at the distances 8.0 cm and 3.5 cm, respectively from the centre.

Solution: False. As the larger chord is at smaller distance from the centre.

EXERCISE 10.2

Write **True** or **False** and justify your answer in each of the following:

- Two chords AB and CD of a circle are each at distances 4 cm from the centre. Then $AB = CD$.
- Two chords AB and AC of a circle with centre O are on the opposite sides of OA. Then $\angle OAB = \angle OAC$.
- Two congruent circles with centres O and O' intersect at two points A and B. Then $\angle AOB = \angle AO'B$.
- Through three collinear points a circle can be drawn.
- A circle of radius 3 cm can be drawn through two points A, B such that $AB = 6$ cm.

6. If AOB is a diameter of a circle and C is a point on the circle, then $AC^2 + BC^2 = AB^2$.
7. $ABCD$ is a cyclic quadrilateral such that $\angle A = 90^\circ$, $\angle B = 70^\circ$, $\angle C = 95^\circ$ and $\angle D = 105^\circ$.
8. If A, B, C, D are four points such that $\angle BAC = 30^\circ$ and $\angle BDC = 60^\circ$, then D is the centre of the circle through A, B and C .
9. If A, B, C and D are four points such that $\angle BAC = 45^\circ$ and $\angle BDC = 45^\circ$, then A, B, C, D are concyclic.
10. In Fig. 10.10, if AOB is a diameter and $\angle ADC = 120^\circ$, then $\angle CAB = 30^\circ$.

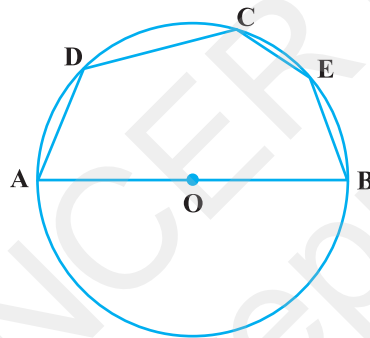

Fig. 10.10

(D) Short Answer Questions

Sample Question 1 : In Fig. 10.11, AOC is a diameter of the circle and arc $AXB = \frac{1}{2}$ arc BYC . Find $\angle BOC$.

Solution :

As $\text{arc } AXB = \frac{1}{2} \text{ arc } BYC,$

$$\angle AOB = \frac{1}{2} \angle BOC$$

Also $\angle AOB + \angle BOC = 180^\circ$

Therefore, $\frac{1}{2} \angle BOC + \angle BOC = 180^\circ$

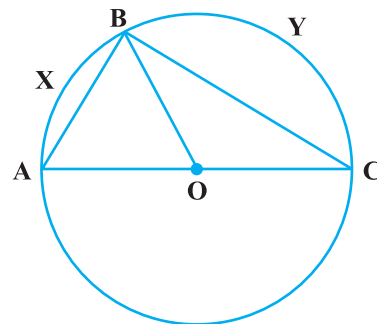

Fig. 10.11

or
$$\angle BOC = \frac{2}{3} \times 180^\circ = 120^\circ$$

Sample Question 2 : In Fig. 10.12, $\angle ABC = 45^\circ$, prove that $OA \perp OC$.

Solution :
$$\angle ABC = \frac{1}{2} \angle AOC$$

i.e., $\angle AOC = 2 \angle ABC = 2 \times 45^\circ = 90^\circ$

or
$$OA \perp OC$$

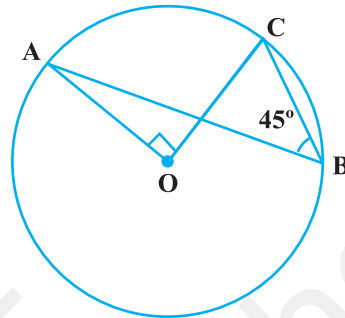

Fig. 10.12

EXERCISE 10.3

1. If arcs AXB and CYD of a circle are congruent, find the ratio of AB and CD.
2. If the perpendicular bisector of a chord AB of a circle PXAQBY intersects the circle at P and Q, prove that arc PXA \cong Arc PYB.
3. A, B and C are three points on a circle. Prove that the perpendicular bisectors of AB, BC and CA are concurrent.
4. AB and AC are two equal chords of a circle. Prove that the bisector of the angle BAC passes through the centre of the circle.
5. If a line segment joining mid-points of two chords of a circle passes through the centre of the circle, prove that the two chords are parallel.
6. ABCD is such a quadrilateral that A is the centre of the circle passing through B, C and D. Prove that

$$\angle CBD + \angle CDB = \frac{1}{2} \angle BAD$$

7. O is the circumcentre of the triangle ABC and D is the mid-point of the base BC. Prove that $\angle BOD = \angle A$.
8. On a common hypotenuse AB, two right triangles ACB and ADB are situated on opposite sides. Prove that $\angle BAC = \angle BDC$.
9. Two chords AB and AC of a circle subtends angles equal to 90° and 150° , respectively at the centre. Find $\angle BAC$, if AB and AC lie on the opposite sides of the centre.
10. If BM and CN are the perpendiculars drawn on the sides AC and AB of the triangle ABC, prove that the points B, C, M and N are concyclic.
11. If a line is drawn parallel to the base of an isosceles triangle to intersect its equal sides, prove that the quadrilateral so formed is cyclic.

12. If a pair of opposite sides of a cyclic quadrilateral are equal, prove that its diagonals are also equal.
13. The circumcentre of the triangle ABC is O. Prove that $\angle OBC + \angle BAC = 90^\circ$.
14. A chord of a circle is equal to its radius. Find the angle subtended by this chord at a point in major segment.
15. In Fig.10.13, $\angle ADC = 130^\circ$ and chord BC = chord BE. Find $\angle CBE$.

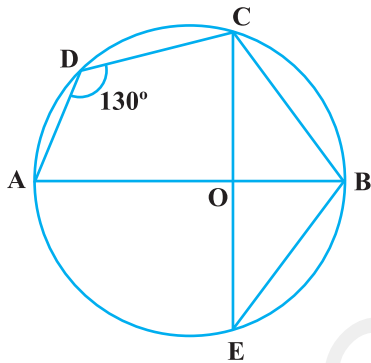

Fig. 10.13

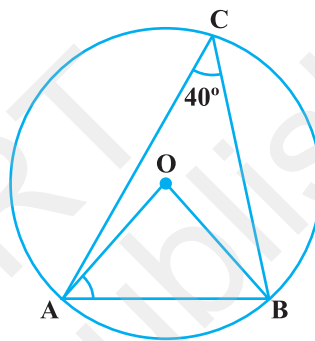

Fig. 10.14

16. In Fig.10.14, $\angle ACB = 40^\circ$. Find $\angle OAB$.
17. A quadrilateral ABCD is inscribed in a circle such that AB is a diameter and $\angle ADC = 130^\circ$. Find $\angle BAC$.
18. Two circles with centres O and O' intersect at two points A and B. A line PQ is drawn parallel to OO' through A(or B) intersecting the circles at P and Q. Prove that $PQ = 2 OO'$.
19. In Fig.10.15, AOB is a diameter of the circle and C, D, E are any three points on the semi-circle. Find the value of $\angle ACD + \angle BED$.

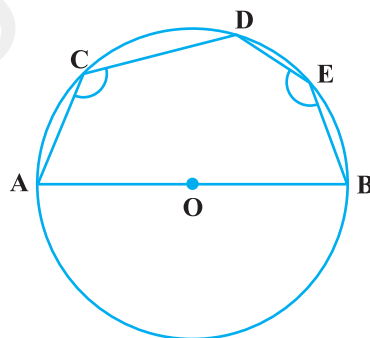

Fig. 10.15

20. In Fig. 10.16, $\angle OAB = 30^\circ$ and $\angle OCB = 57^\circ$. Find $\angle BOC$ and $\angle AOC$.

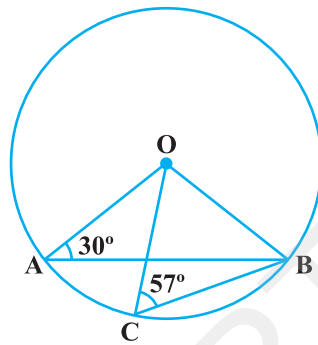

Fig. 10.16

(E) Long Answer Questions

Sample Question 1 : Prove that two circles cannot intersect at more than two points.

Solution : Let there be two circles which intersect at three points say at A, B and C. Clearly, A, B and C are not collinear. We know that through three non-collinear points A, B and C one and only one circle can pass. Therefore, there cannot be two circles passing through A, B and C. In other words, the two circles cannot intersect at more than two points.

Sample Question 2 : Prove that among all the chords of a circle passing through a given point inside the circle that one is smallest which is perpendicular to the diameter passing through the point.

Solution : Let P be the given point inside a circle with centre O. Draw the chord AB which is perpendicular to the diameter XY through P. Let CD be any other chord through P. Draw ON perpendicular to CD from O. Then $\triangle ONP$ is a right triangle (Fig.10.17). Therefore, its hypotenuse OP is larger than ON. We know that the chord nearer to the centre is larger than the chord which is farther to the centre. Therefore, $CD > AB$. In other words, AB is the smallest of all chords passing through P.

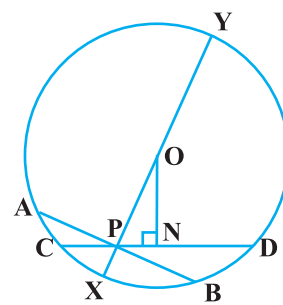

Fig. 10.17

EXERCISE 10.4

1. If two equal chords of a circle intersect, prove that the parts of one chord are separately equal to the parts of the other chord.
2. If non-parallel sides of a trapezium are equal, prove that it is cyclic.
3. If P, Q and R are the mid-points of the sides BC, CA and AB of a triangle and AD is the perpendicular from A on BC, prove that P, Q, R and D are concyclic.
4. ABCD is a parallelogram. A circle through A, B is so drawn that it intersects AD at P and BC at Q. Prove that P, Q, C and D are concyclic.
5. Prove that angle bisector of any angle of a triangle and perpendicular bisector of the opposite side if intersect, they will intersect on the circumcircle of the triangle.
6. If two chords AB and CD of a circle AYDZBWCX intersect at right angles (see Fig.10.18), prove that arc CXA + arc DZB = arc AYD + arc BWC = semi-circle.

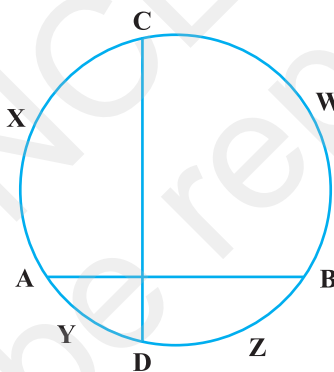

Fig. 10.18

7. If ABC is an equilateral triangle inscribed in a circle and P be any point on the minor arc BC which does not coincide with B or C, prove that PA is angle bisector of $\angle BPC$.
8. In Fig. 10.19, AB and CD are two chords of a circle intersecting each other at point E. Prove that $\angle AEC = \frac{1}{2}$ (Angle subtended by arc CXA at centre + angle subtended by arc DYB at the centre).

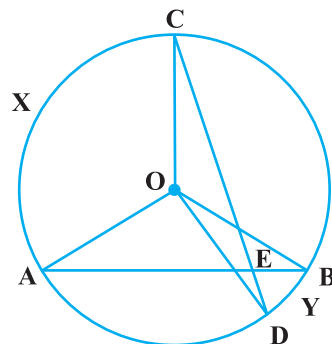

Fig. 10.19

9. If bisectors of opposite angles of a cyclic quadrilateral ABCD intersect the circle, circumscribing it at the points P and Q, prove that PQ is a diameter of the circle.
10. A circle has radius $\sqrt{2}$ cm. It is divided into two segments by a chord of length 2 cm. Prove that the angle subtended by the chord at a point in major segment is 45° .
11. Two equal chords AB and CD of a circle when produced intersect at a point P. Prove that $PB = PD$.
12. AB and AC are two chords of a circle of radius r such that $AB = 2AC$. If p and q are the distances of AB and AC from the centre, prove that $4q^2 = p^2 + 3r^2$.
13. In Fig. 10.20, O is the centre of the circle, $\angle BCO = 30^\circ$. Find x and y .

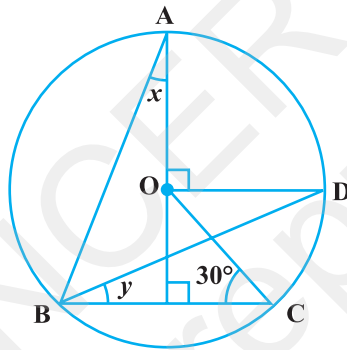

Fig. 10.20

14. In Fig. 10.21, O is the centre of the circle, $BD = OD$ and $CD \perp AB$. Find $\angle CAB$.

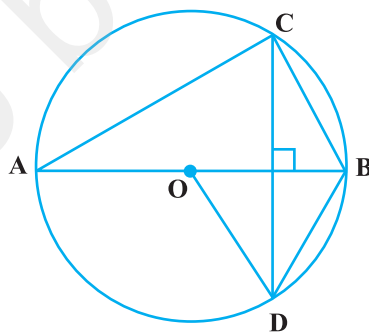

Fig. 10.21

CONSTRUCTIONS

(A) Main Concepts and Results

- To bisect a given angle,
- To draw the perpendicular bisector of a line segment,
- To construct angles of 15° , 30° , 45° , 60° , 90° , etc.
- To construct a triangle given its base, a base angle and the sum of other two sides,
- To construct a triangle given its base, a base angle and the difference of other two sides,
- To construct a triangle given its perimeter and the two base angles
- Geometrical construction means using only a ruler and a pair of compasses as geometrical instruments.

(B) Multiple Choice Questions

Sample Question 1: With the help of a ruler and a compass, it is possible to construct an angle of :

- (A) 35° (B) 40° (C) 37.5° (D) 47.5°

Solution : Answer (C)

Sample Question 2: The construction of a triangle ABC in which $AB = 4$ cm, $\angle A = 60^\circ$ is not possible when difference of BC and AC is equal to:

- (A) 3.5 cm (B) 4.5 cm (C) 3 cm (D) 2.5 cm

Solution : Answer (B)

EXERCISE 11.1

- With the help of a ruler and a compass it is not possible to construct an angle of :
(A) 37.5° (B) 40° (C) 22.5° (D) 67.5°
- The construction of a triangle ABC, given that $BC = 6$ cm, $\angle B = 45^\circ$ is not possible when difference of AB and AC is equal to:
(A) 6.9 cm (B) 5.2 cm (C) 5.0 cm (D) 4.0 cm
- The construction of a triangle ABC, given that $BC = 3$ cm, $\angle C = 60^\circ$ is possible when difference of AB and AC is equal to :
(A) 3.2 cm (B) 3.1 cm (C) 3 cm (D) 2.8 cm

(C) Short Answer Questions with Reasoning

Write **True** or **False** and give reasons for your answer.

Sample Question 1 : An angle of 67.5° can be constructed.

Solution : True. As $67.5^\circ = \frac{135^\circ}{2} = \frac{1}{2}(90^\circ + 45^\circ)$.

EXERCISE 11.2

Write **True** or **False** in each of the following. Give reasons for your answer:

- An angle of 52.5° can be constructed.
- An angle of 42.5° can be constructed.
- A triangle ABC can be constructed in which $AB = 5$ cm, $\angle A = 45^\circ$ and $BC + AC = 5$ cm.
- A triangle ABC can be constructed in which $BC = 6$ cm, $\angle C = 30^\circ$ and $AC - AB = 4$ cm.
- A triangle ABC can be constructed in which $\angle B = 105^\circ$, $\angle C = 90^\circ$ and $AB + BC + AC = 10$ cm.
- A triangle ABC can be constructed in which $\angle B = 60^\circ$, $\angle C = 45^\circ$ and $AB + BC + AC = 12$ cm.

(D) Short Answer Questions

Sample Question 1 : Construct a triangle ABC in which $BC = 7.5$ cm, $\angle B = 45^\circ$ and $AB - AC = 4$ cm.

Solution : See Mathematics Textbook for Class IX.

EXERCISE 11.3

1. Draw an angle of 110° with the help of a protractor and bisect it. Measure each angle.
2. Draw a line segment AB of 4 cm in length. Draw a line perpendicular to AB through A and B, respectively. Are these lines parallel?
3. Draw an angle of 80° with the help of a protractor. Then construct angles of (i) 40° (ii) 160° and (iii) 120° .
4. Construct a triangle whose sides are 3.6 cm, 3.0 cm and 4.8 cm. Bisect the smallest angle and measure each part.
5. Construct a triangle ABC in which $BC = 5$ cm, $\angle B = 60^\circ$ and $AC + AB = 7.5$ cm.
6. Construct a square of side 3 cm.
7. Construct a rectangle whose adjacent sides are of lengths 5 cm and 3.5 cm.
8. Construct a rhombus whose side is of length 3.4 cm and one of its angles is 45° .

(E) Long Answer Questions

Sample Question 1 : Construct an equilateral triangle if its altitude is 6 cm. Give justification for your construction.

Solution : Draw a line XY. Take any point D on this line. Construct perpendicular PD on XY. Cut a line segment AD from D equal to 6 cm.

Make angles equal to 30° at A on both sides of AD, say $\angle CAD$ and $\angle BAD$ where B and C lie on XY. Then ABC is the required triangle.

Justification

Since $\angle A = 30^\circ + 30^\circ = 60^\circ$ and $AD \perp BC$, $\triangle ABC$ is an equilateral triangle with altitude $AD = 6$ cm.

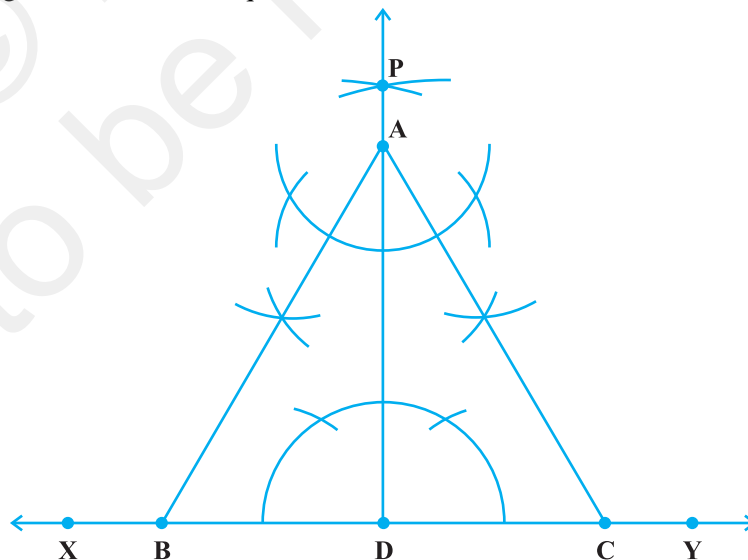

Fig. 11.1

EXERCISE 11.4

Construct each of the following and give justification :

1. A triangle if its perimeter is 10.4 cm and two angles are 45° and 120° .
2. A triangle PQR given that $QR = 3\text{cm}$, $\angle PQR = 45^\circ$ and $QP - PR = 2\text{ cm}$.
3. A right triangle when one side is 3.5 cm and sum of other sides and the hypotenuse is 5.5 cm.
4. An equilateral triangle if its altitude is 3.2 cm.
5. A rhombus whose diagonals are 4 cm and 6 cm in lengths.

HERON'S FORMULA

(A) Main Concepts and Results

- **Rectangle**

- (a) Area = length \times breadth
- (b) Perimeter = 2 (length + breadth)
- (c) Diagonal = $\sqrt{(\text{length})^2 + (\text{breadth})^2}$

- **Square**

- (a) Area = (side)²
- (b) Perimeter = 4 \times side
- (c) Diagonal = $\sqrt{2}$ \times side

- **Triangle with base (b) and altitude (h)**

$$\text{Area} = \frac{1}{2} \times b \times h$$

- **Triangle with sides as a, b, c**

- (i) Semi-perimeter = $\frac{a+b+c}{2} = s$

- (ii) Area = $\sqrt{s(s-a)(s-b)(s-c)}$ (Heron's Formula)

- **Isosceles triangle, with base a and equal sides b**

$$\text{Area of isosceles triangle} = \frac{a}{4} \sqrt{4b^2 - a^2}$$

- **Equilateral triangle with side a**

$$\text{Area} = \frac{\sqrt{3}}{4} a^2$$

- **Parallelogram with base b and altitude h**

$$\text{Area} = bh$$

- **Rhombus with diagonals d_1 and d_2**

$$(a) \quad \text{Area} = \frac{1}{2} d_1 \times d_2$$

$$(b) \quad \text{Perimeter} = 2\sqrt{d_1^2 + d_2^2}$$

- **Trapezium with parallel sides a and b , and the distance between two parallel sides as h .**

$$\text{Area} = \frac{1}{2} (a + b) \times h$$

- **Regular hexagon with side a**

$$\text{Area} = 6 \times \text{Area of an equilateral triangle with side } a$$

$$= 6 \times \frac{\sqrt{3}}{4} a^2 = \frac{3}{2} \sqrt{3} a^2$$

(B) Multiple Choice Questions

Write the correct answer:

Sample Question 1 : The base of a right triangle is 8 cm and hypotenuse is 10 cm. Its area will be

- (A) 24 cm² (B) 40 cm² (C) 48 cm² (D) 80 cm²

Solution : Answer (A)

EXERCISE 12.1

1. An isosceles right triangle has area 8 cm². The length of its hypotenuse is

- (A) $\sqrt{32}$ cm (B) $\sqrt{16}$ cm (C) $\sqrt{48}$ cm (D) $\sqrt{24}$ cm

2. The perimeter of an equilateral triangle is 60 m. The area is
 (A) $10\sqrt{3} \text{ m}^2$ (B) $15\sqrt{3} \text{ m}^2$ (C) $20\sqrt{3} \text{ m}^2$ (D) $100\sqrt{3} \text{ m}^2$
3. The sides of a triangle are 56 cm, 60 cm and 52 cm long. Then the area of the triangle is
 (A) 1322 cm^2 (B) 1311 cm^2 (C) 1344 cm^2 (D) 1392 cm^2
4. The area of an equilateral triangle with side $2\sqrt{3} \text{ cm}$ is
 (A) 5.196 cm^2 (B) 0.866 cm^2 (C) 3.496 cm^2 (D) 1.732 cm^2
5. The length of each side of an equilateral triangle having an area of $9\sqrt{3} \text{ cm}^2$ is
 (A) 8 cm (B) 36 cm (C) 4 cm (D) 6 cm
6. If the area of an equilateral triangle is $16\sqrt{3} \text{ cm}^2$, then the perimeter of the triangle is
 (A) 48 cm (B) 24 cm (C) 12 cm (D) 36 cm
7. The sides of a triangle are 35 cm, 54 cm and 61 cm, respectively. The length of its longest altitude
 (A) $16\sqrt{5} \text{ cm}$ (B) $10\sqrt{5} \text{ cm}$ (C) $24\sqrt{5} \text{ cm}$ (D) 28 cm
8. The area of an isosceles triangle having base 2 cm and the length of one of the equal sides 4 cm, is
 (A) $\sqrt{15} \text{ cm}^2$ (B) $\sqrt{\frac{15}{2}} \text{ cm}^2$ (C) $2\sqrt{15} \text{ cm}^2$ (D) $4\sqrt{15} \text{ cm}^2$
9. The edges of a triangular board are 6 cm, 8 cm and 10 cm. The cost of painting it at the rate of 9 paise per cm^2 is
 (A) Rs 2.00 (B) Rs 2.16 (C) Rs 2.48 (D) Rs 3.00

(C) Short Answer Questions with Reasoning

Write **True** or **False** and justify your answer:

Sample Question 1 : If a, b, c are the lengths of three sides of a triangle, then area of a triangle = $\sqrt{s(s-a)(s-b)(s-c)}$, where s = perimeter of triangle.

Solution : False. Since in Heron's formula,

$$s = \frac{1}{2}(a+b+c)$$

$$= \frac{1}{2}(\text{perimeter of triangle})$$

EXERCISE 12.2

Write **True** or **False** and justify your answer:

1. The area of a triangle with base 4 cm and height 6 cm is 24 cm^2 .
2. The area of $\triangle ABC$ is 8 cm^2 in which $AB = AC = 4 \text{ cm}$ and $\angle A = 90^\circ$.
3. The area of the isosceles triangle is $\frac{5}{4}\sqrt{11} \text{ cm}^2$, if the perimeter is 11 cm and the base is 5 cm.
4. The area of the equilateral triangle is $20\sqrt{3} \text{ cm}^2$ whose each side is 8 cm.
5. If the side of a rhombus is 10 cm and one diagonal is 16 cm, the area of the rhombus is 96 cm^2 .
6. The base and the corresponding altitude of a parallelogram are 10 cm and 3.5 cm, respectively. The area of the parallelogram is 30 cm^2 .
7. The area of a regular hexagon of side 'a' is the sum of the areas of the five equilateral triangles with side a.
8. The cost of levelling the ground in the form of a triangle having the sides 51 m, 37 m and 20 m at the rate of Rs 3 per m^2 is Rs 918.
9. In a triangle, the sides are given as 11 cm, 12 cm and 13 cm. The length of the altitude is 10.25 cm corresponding to the side having length 12 cm.

(D) Short Answer Questions

Sample Question 1 : The sides of a triangular field are 41 m, 40 m and 9 m. Find the number of rose beds that can be prepared in the field, if each rose bed, on an average needs 900 cm^2 space.

Solution : Let $a = 41 \text{ m}$, $b = 40 \text{ m}$, $c = 9 \text{ m}$.

$$s = \frac{a+b+c}{2} = \frac{41+40+9}{2} \text{ m} = 45 \text{ m}$$

Area of the triangular field

$$\begin{aligned}
 &= \sqrt{s(s-a)(s-b)(s-c)} \\
 &= \sqrt{45(45-41)(45-40)(45-9)} \\
 &= \sqrt{45 \times 4 \times 5 \times 36} = 180 \text{ m}^2
 \end{aligned}$$

So, the number of rose beds = $\frac{180}{0.09} = 2000$

Sample Question 2 : Calculate the area of the shaded region in Fig. 12.1.

Solution : For the triangle having the sides 122 m, 120 m and 22 m :

$$s = \frac{122 + 120 + 22}{2} = 132$$

$$\begin{aligned}
 \text{Area of the triangle} &= \sqrt{s(s-a)(s-b)(s-c)} \\
 &= \sqrt{132(132-122)(132-120)(132-22)} \\
 &= \sqrt{132 \times 10 \times 12 \times 110} \\
 &= 1320 \text{ m}^2
 \end{aligned}$$

For the triangle having the sides 22 m, 24 m and 26 m:

$$s = \frac{22 + 24 + 26}{2} = 36$$

$$\begin{aligned}
 \text{Area of the triangle} &= \sqrt{36(36-22)(36-24)(36-26)} \\
 &= \sqrt{36 \times 14 \times 12 \times 10} \\
 &= 24\sqrt{105} \\
 &= 24 \times 10.25 \text{ m}^2 \text{ (approx.)} \\
 &= 246 \text{ m}^2
 \end{aligned}$$

Therefore, the area of the shaded portion

$$\begin{aligned}
 &= (1320 - 246) \text{ m}^2 \\
 &= 1074 \text{ m}^2
 \end{aligned}$$

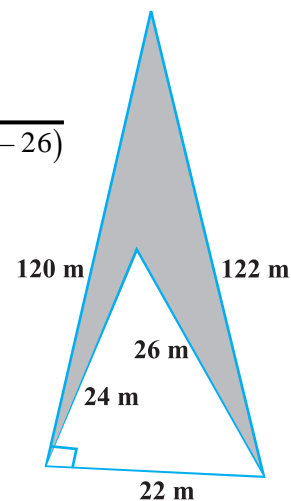
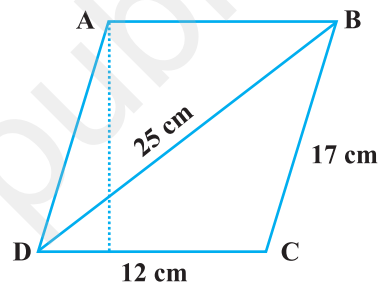
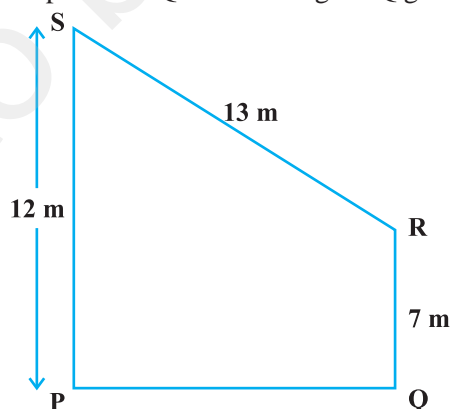

Fig. 12.1

EXERCISE 12.3

- 1 Find the cost of laying grass in a triangular field of sides 50 m, 65 m and 65 m at the rate of Rs 7 per m^2 .
- 2 The triangular side walls of a flyover have been used for advertisements. The sides of the walls are 13 m, 14 m and 15 m. The advertisements yield an earning of Rs 2000 per m^2 a year. A company hired one of its walls for 6 months. How much rent did it pay?
- 3 From a point in the interior of an equilateral triangle, perpendiculars are drawn on the three sides. The lengths of the perpendiculars are 14 cm, 10 cm and 6 cm. Find the area of the triangle.
- 4 The perimeter of an isosceles triangle is 32 cm. The ratio of the equal side to its base is 3 : 2. Find the area of the triangle.
- 5 Find the area of a parallelogram given in Fig. 12.2. Also find the length of the altitude from vertex A on the side DC.
- 6 A field in the form of a parallelogram has sides 60 m and 40 m and one of its diagonals is 80 m long. Find the area of the parallelogram.
- 7 The perimeter of a triangular field is 420 m and its sides are in the ratio 6 : 7 : 8. Find the area of the triangular field.
- 8 The sides of a quadrilateral ABCD are 6 cm, 8 cm, 12 cm and 14 cm (taken in order) respectively, and the angle between the first two sides is a right angle. Find its area.
- 9 A rhombus shaped sheet with perimeter 40 cm and one diagonal 12 cm, is painted on both sides at the rate of Rs 5 per m^2 . Find the cost of painting.
- 10 Find the area of the trapezium PQRS with height PQ given in Fig. 12.3

**Fig. 12.2****Fig. 12.3**

(E) Long Answer Questions

Sample Question 1 : If each side of a triangle is doubled, then find the ratio of area of the new triangle thus formed and the given triangle.

Solution : Let a, b, c be the sides of the triangle (existing) and s be its semi-perimeter.

$$\text{Then, } s = \frac{a+b+c}{2}$$

$$\text{or, } 2s = a + b + c \quad (1)$$

$$\text{Area of the existing triangle} = \sqrt{s(s-a)(s-b)(s-c)} = \Delta, \text{ say}$$

According to the statement, the sides of the new triangle will be $2a, 2b$ and $2c$. Let S be the semi-perimeter of the new triangle.

$$S = \frac{2a + 2b + 2c}{2} = a + b + c \quad (2)$$

From (1) and (2), we get

$$S = 2s \quad (3)$$

Area of the new triangle

$$= \sqrt{S(S-2a)(S-2b)(S-2c)}$$

Putting the values, we get

$$= \sqrt{2s(2s-2a)(2s-2b)(2s-2c)}$$

$$= \sqrt{16s(s-a)(s-b)(s-c)}$$

$$= 4\sqrt{s(s-a)(s-b)(s-c)} = 4\Delta$$

Therefore, the required ratio is 4:1.

EXERCISE 12.4

- How much paper of each shade is needed to make a kite given in Fig. 12.4, in which ABCD is a square with diagonal 44 cm.

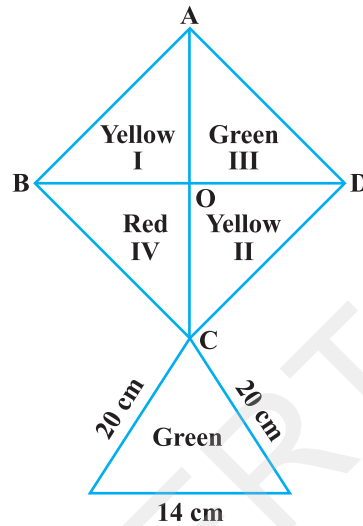

Fig. 12.4

2. The perimeter of a triangle is 50 cm. One side of a triangle is 4 cm longer than the smaller side and the third side is 6 cm less than twice the smaller side. Find the area of the triangle.
3. The area of a trapezium is 475 cm^2 and the height is 19 cm. Find the lengths of its two parallel sides if one side is 4 cm greater than the other.
4. A rectangular plot is given for constructing a house, having a measurement of 40 m long and 15 m in the front. According to the laws, a minimum of 3 m, wide space should be left in the front and back each and 2 m wide space on each of other sides. Find the largest area where house can be constructed.
5. A field is in the shape of a trapezium having parallel sides 90 m and 30 m. These sides meet the third side at right angles. The length of the fourth side is 100 m. If it costs Rs 4 to plough 1 m^2 of the field, find the total cost of ploughing the field.
6. In Fig. 12.5, $\triangle ABC$ has sides $AB = 7.5 \text{ cm}$, $AC = 6.5 \text{ cm}$ and $BC = 7 \text{ cm}$. On base BC a parallelogram DBCE of same area as that of $\triangle ABC$ is constructed. Find the height DF of the parallelogram.
7. The dimensions of a rectangle ABCD are $51 \text{ cm} \times 25 \text{ cm}$. A trapezium PQCD with its parallel

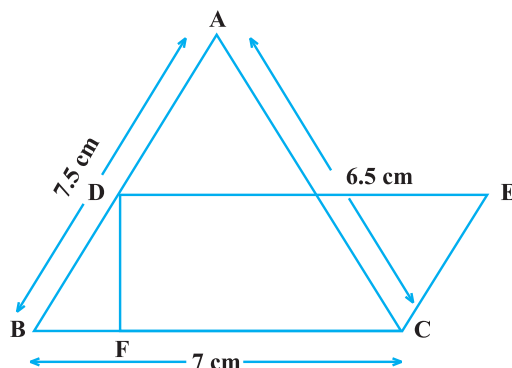

Fig. 12.5

sides QC and PD in the ratio 9 : 8, is cut off from the rectangle as shown in the Fig. 12.6. If the area of the trapezium PQCD is $\frac{5}{6}$ th part of the area of the rectangle, find the lengths QC and PD.

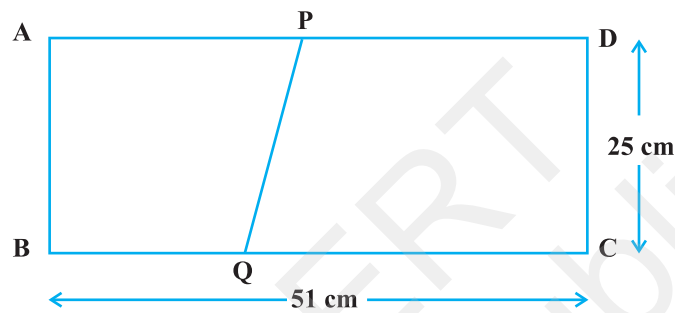

Fig. 12.6

8. A design is made on a rectangular tile of dimensions 50 cm \times 70 cm as shown in Fig. 12.7. The design shows 8 triangles, each of sides 26 cm, 17 cm and 25 cm. Find the total area of the design and the remaining area of the tile.

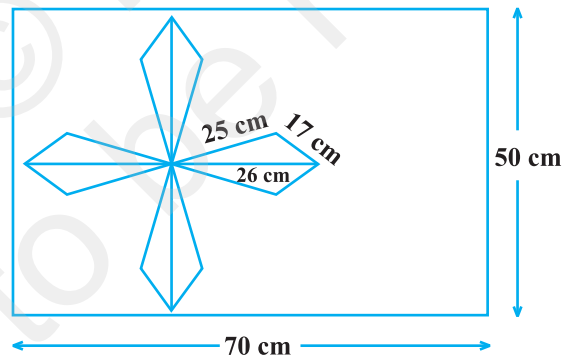

Fig. 12.7

SURFACE AREAS AND VOLUMES

(A) Main Concepts and Results

- **Cuboid whose length = l , breadth = b and height = h**
 - (a) Volume of cuboid = lbh
 - (b) Total surface area of cuboid = $2 (lb + bh + hl)$
 - (c) Lateral surface area of cuboid = $2 h (l + b)$
 - (d) Diagonal of cuboid = $\sqrt{l^2 + b^2 + h^2}$
- **Cube whose edge = a**
 - (a) Volume of cube = a^3
 - (b) Lateral Surface area = $4a^2$
 - (c) Total surface area of cube = $6a^2$
 - (d) Diagonal of cube = $a\sqrt{3}$
- **Cylinder whose radius = r , height = h**
 - (a) Volume of cylinder = $\pi r^2 h$
 - (b) Curved surface area of cylinder = $2\pi r h$
 - (c) Total surface area of cylinder = $2\pi r (r + h)$
- **Cone having height = h , radius = r and slant height = l**
 - (a) Volume of cone = $\frac{1}{3} \pi r^2 h$
 - (b) Curved surface area of cone = $\pi r l$

(c) Total surface area of cone = $\pi r (l + r)$

(d) Slant height of cone (l) = $\sqrt{h^2 + r^2}$

• **Sphere whose radius = r**

(a) Volume of sphere = $\frac{4}{3}\pi r^3$

(b) Surface area of sphere = $4\pi r^2$

• **Hemisphere whose radius = r**

(a) Volume of hemisphere = $\frac{2}{3}\pi r^3$

(b) Curved surface area of hemisphere = $2\pi r^2$

(c) Total surface area of hemisphere = $3\pi r^2$

(B) Multiple Choice Questions

Write the correct answer

Sample Question 1 : In a cylinder, if radius is halved and height is doubled, the volume will be

- (A) same (B) doubled (C) halved (D) four times

Solution: Answer (C)

EXERCISE 13.1

Write the correct answer in each of the following :

1. The radius of a sphere is $2r$, then its volume will be

- (A) $\frac{4}{3}\pi r^3$ (B) $4\pi r^3$ (C) $\frac{8\pi r^3}{3}$ (D) $\frac{32}{3}\pi r^3$

2. The total surface area of a cube is 96 cm^2 . The volume of the cube is:

- (A) 8 cm^3 (B) 512 cm^3 (C) 64 cm^3 (D) 27 cm^3

3. A cone is 8.4 cm high and the radius of its base is 2.1 cm . It is melted and recast into a sphere. The radius of the sphere is :

- (A) 4.2 cm (B) 2.1 cm (C) 2.4 cm (D) 1.6 cm

4. In a cylinder, radius is doubled and height is halved, curved surface area will be

- (A) halved (B) doubled (C) same (D) four times
5. The total surface area of a cone whose radius is $\frac{r}{2}$ and slant height $2l$ is
- (A) $2\pi r(l+r)$ (B) $\pi r(l + \frac{r}{4})$ (C) $\pi r(l+r)$ (D) $2\pi rl$
6. The radii of two cylinders are in the ratio of 2:3 and their heights are in the ratio of 5:3. The ratio of their volumes is:
- (A) 10 : 17 (B) 20 : 27 (C) 17 : 27 (D) 20 : 37
7. The lateral surface area of a cube is 256 m^2 . The volume of the cube is
- (A) 512 m^3 (B) 64 m^3 (C) 216 m^3 (D) 256 m^3
8. The number of planks of dimensions $(4 \text{ m} \times 50 \text{ cm} \times 20 \text{ cm})$ that can be stored in a pit which is 16 m long, 12m wide and 4 m deep is
- (A) 1900 (B) 1920 (C) 1800 (D) 1840
9. The length of the longest pole that can be put in a room of dimensions $(10 \text{ m} \times 10 \text{ m} \times 5 \text{ m})$ is
- (A) 15 m (B) 16 m (C) 10 m (D) 12 m
10. The radius of a hemispherical balloon increases from 6 cm to 12 cm as air is being pumped into it. The ratios of the surface areas of the balloon in the two cases is
- (A) 1 : 4 (B) 1 : 3 (C) 2 : 3 (D) 2 : 1

(C) Short Answer Questions with Reasoning

Write **True** or **False** and justify your answer.

Sample Question 1 : A right circular cylinder just encloses a sphere of radius r as shown in Fig 13.1. The surface area of the sphere is equal to the curved surface area of the cylinder.

Solution : True.

Here, radius of the sphere = radius of the cylinder = r

Diameter of the sphere = height of the cylinder = $2r$

Surface area of the sphere = $4\pi r^2$

Curved surface area of the cylinder = $2\pi r(2r) = 4\pi r^2$

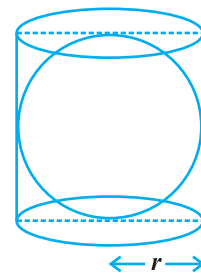

Fig. 13.1

Sample Question 2 : An edge of a cube measures r cm. If the largest possible right circular cone is cut out of this cube, then the volume of the cone (in cm^3) is $\frac{1}{6}\pi r^3$.

Solution : False.

Height of the cone = r cm.

Diameter of the base = r cm.

$$\begin{aligned} \text{Therefore, volume of the cone} &= \frac{1}{3} \pi \left(\frac{r}{2} \right)^2 \cdot r \\ &= \frac{1}{12} \pi r^3 \end{aligned}$$

EXERCISE 13.2

Write **True** or **False** and justify your answer in each of the following :

1. The volume of a sphere is equal to two-third of the volume of a cylinder whose height and diameter are equal to the diameter of the sphere.
2. If the radius of a right circular cone is halved and height is doubled, the volume will remain unchanged.
3. In a right circular cone, height, radius and slant height do not always be sides of a right triangle.
4. If the radius of a cylinder is doubled and its curved surface area is not changed, the height must be halved.
5. The volume of the largest right circular cone that can be fitted in a cube whose edge is $2r$ equals to the volume of a hemisphere of radius r .
6. A cylinder and a right circular cone are having the same base and same height. The volume of the cylinder is three times the volume of the cone.
7. A cone, a hemisphere and a cylinder stand on equal bases and have the same height. The ratio of their volumes is 1 : 2 : 3.
8. If the length of the diagonal of a cube is $6\sqrt{3}$ cm, then the length of the edge of the cube is 3 cm.
9. If a sphere is inscribed in a cube, then the ratio of the volume of the cube to the volume of the sphere will be $6 : \pi$.
10. If the radius of a cylinder is doubled and height is halved, the volume will be doubled.

(D) Short Answer Questions

Sample Question 1: The surface area of a sphere of radius 5 cm is five times the area of the curved surface of a cone of radius 4 cm. Find the height and the volume of

the cone (taking $\pi = \frac{22}{7}$).

Solution: Surface area of the sphere = $4\pi \times 5 \times 5 \text{ cm}^2$.

Curved surface area of the cone = $\pi \times 4 \times l \text{ cm}^2$,

where l is the slant height of the cone.

According to the statement

$$4\pi \times 5 \times 5 = 5 \times \pi \times 4 \times l$$

or $l = 5 \text{ cm}$.

Now, $l^2 = h^2 + r^2$

Therefore, $(5)^2 = h^2 + (4)^2$

where h is the height of the cone

or $(5)^2 - (4)^2 = h^2$

or $(5 + 4)(5 - 4) = h^2$

or $9 = h^2$

or $h = 3 \text{ cm}$

$$\text{Volume of Cone} = \frac{1}{3} \pi r^2 h$$

$$= \frac{1}{3} \times \frac{22}{7} \times 4 \times 4 \times 3 \text{ cm}^3$$

$$= \frac{22 \times 16}{7} \text{ cm}^3$$

$$= \frac{352}{7} \text{ cm}^3 = 50.29 \text{ cm}^3 \text{ (approximately)}$$

Sample Question 2: The radius of a sphere is increased by 10%. Prove that the volume will be increased by 33.1% approximately.

Solution: The volume of a sphere = $\frac{4}{3} \pi r^3$

10% increase in radius = 10% r

$$\text{Increased radius} = r + \frac{1}{10}r = \frac{11}{10}r$$

The volume of the sphere now becomes

$$\begin{aligned} \frac{4}{3}\pi\left(\frac{11}{10}r\right)^3 &= \frac{4}{3}\pi \times \frac{1331}{1000}r^3 \\ &= \frac{4}{3}\pi \times 1.331r^3 \end{aligned}$$

$$\text{Increase in volume} = \frac{4}{3}\pi \times 1.331r^3 - \frac{4}{3}\pi r^3$$

$$= \frac{4}{3}\pi r^3 (1.331 - 1) = \frac{4}{3}\pi r^3 \times 0.331$$

$$\text{Percentage increase in volume} = \left[\frac{\frac{4}{3}\pi r^3 \times 0.331}{\frac{4}{3}\pi r^3} \times 100 \right] = 33.1$$

EXERCISE 13.3

1. Metal spheres, each of radius 2 cm, are packed into a rectangular box of internal dimensions 16 cm \times 8 cm \times 8 cm. When 16 spheres are packed the box is filled with preservative liquid. Find the volume of this liquid. Give your answer to the nearest integer. [Use $\pi=3.14$]
2. A storage tank is in the form of a cube. When it is full of water, the volume of water is 15.625 m³. If the present depth of water is 1.3 m, find the volume of water already used from the tank.
3. Find the amount of water displaced by a solid spherical ball of diameter 4.2 cm, when it is completely immersed in water.
4. How many square metres of canvas is required for a conical tent whose height is 3.5 m and the radius of the base is 12 m?

5. Two solid spheres made of the same metal have weights 5920 g and 740 g, respectively. Determine the radius of the larger sphere, if the diameter of the smaller one is 5 cm.
6. A school provides milk to the students daily in a cylindrical glasses of diameter 7 cm. If the glass is filled with milk upto an height of 12 cm, find how many litres of milk is needed to serve 1600 students.
7. A cylindrical roller 2.5 m in length, 1.75 m in radius when rolled on a road was found to cover the area of 5500 m². How many revolutions did it make?
8. A small village, having a population of 5000, requires 75 litres of water per head per day. The village has got an overhead tank of measurement 40 m × 25 m × 15 m. For how many days will the water of this tank last?
9. A shopkeeper has one spherical laddoo of radius 5cm. With the same amount of material, how many laddoos of radius 2.5 cm can be made?
10. A right triangle with sides 6 cm, 8 cm and 10 cm is revolved about the side 8 cm. Find the volume and the curved surface of the solid so formed.

(E) Long Answer Questions

Sample Question 1: Rain water which falls on a flat rectangular surface of length 6 m and breadth 4 m is transferred into a cylindrical vessel of internal radius 20cm. What will be the height of water in the cylindrical vessel if the rain fall is 1 cm. Give your answer to the nearest integer. (Take $\pi = 3.14$)

Solution : Let the height of the water level in the cylindrical vessel be h cm

Volume of the rain water = $600 \times 400 \times 1$ cm³

Volume of water in the cylindrical vessel = $\pi (20)^2 \times h$ cm³

According to statement

$$600 \times 400 \times 1 = \pi (20)^2 \times h$$

or
$$h = \frac{600}{3.14} \text{ cm} = 191 \text{ cm}$$

EXERCISE 13.4

1. A cylindrical tube opened at both the ends is made of iron sheet which is 2 cm thick. If the outer diameter is 16 cm and its length is 100 cm, find how many cubic centimeters of iron has been used in making the tube ?
2. A semi-circular sheet of metal of diameter 28cm is bent to form an open conical cup. Find the capacity of the cup.

3. A cloth having an area of 165 m^2 is shaped into the form of a conical tent of radius 5 m
 - (i) How many students can sit in the tent if a student, on an average, occupies $\frac{5}{7} \text{ m}^2$ on the ground?
 - (ii) Find the volume of the cone.
4. The water for a factory is stored in a hemispherical tank whose internal diameter is 14 m. The tank contains 50 kilolitres of water. Water is pumped into the tank to fill to its capacity. Calculate the volume of water pumped into the tank.
5. The volumes of the two spheres are in the ratio 64 : 27. Find the ratio of their surface areas.
6. A cube of side 4 cm contains a sphere touching its sides. Find the volume of the gap in between.
7. A sphere and a right circular cylinder of the same radius have equal volumes. By what percentage does the diameter of the cylinder exceed its height ?
8. 30 circular plates, each of radius 14 cm and thickness 3cm are placed one above the another to form a cylindrical solid. Find :
 - (i) the total surface area
 - (ii) volume of the cylinder so formed.

STATISTICS AND PROBABILITY

(A) Main Concepts and Results

Statistics

Meaning of 'statistics', Primary and secondary data, Raw/ungrouped data, Range of data, Grouped data-class intervals, Class marks, Presentation of data - frequency distribution table, Discrete frequency distribution and continuous frequency distribution.

- Graphical representation of data :
 - (i) Bar graphs
 - (ii) Histograms of uniform width and of varying widths
 - (iii) Frequency polygons
- Measures of Central tendency
 - (a) **Mean**
 - (i) **Mean of raw data**

$$\text{Mean} = \bar{x} = \frac{x_1 + x_2 + \dots + x_n}{n} = \frac{\sum_{i=1}^n x_i}{n}$$

where x_1, x_2, \dots, x_n are n observations.

(ii) Mean of ungrouped data

$$\bar{x} = \frac{\sum f_i x_i}{\sum f_i}$$

where f_i 's are frequencies of x_i 's.

(b) Median

A median is the value of the observation which divides the data into two equal parts, when the data is arranged in ascending (or descending) order.

Calculation of Median

When the ungrouped data is arranged in ascending (or descending) order, the median of data is calculated as follows :

- (i) When the number of observations (n) is odd, the median is the value of the

$$\left(\frac{n+1}{2}\right)^{\text{th}} \text{ observation.}$$

- (ii) When the number of observations (n) is even, the median is the average or

$$\text{mean of the } \left(\frac{n}{2}\right)^{\text{th}} \text{ and } \left(\frac{n}{2} + 1\right)^{\text{th}} \text{ observations.}$$

(c) Mode

The observation that occurs most frequently, i.e., the observation with maximum frequency is called **mode**. Mode of ungrouped data can be determined by observation/inspection.

Probability

- Random experiment or simply an experiment
- Outcomes of an experiment
- Meaning of a trial of an experiment
- The experimental (or empirical) probability of an event E (denoted by P(E)) is given by

$$P(E) = \frac{\text{Number of trials in which the event has happened}}{\text{Total number of trials}}$$

- The probability of an event E can be any number from 0 to 1. It can also be 0 or 1 in some special cases.

(B) Multiple Choice Questions

Write the correct answer in each of the following :

Sample Question 1: The marks obtained by 17 students in a mathematics test (out of 100) are given below :

91, 82, 100, 100, 96, 65, 82, 76, 79, 90, 46, 64, 72, 68, 66, 48, 49.

The range of the data is :

- (A) 46 (B) 54 (C) 90 (D) 100

Solution : Answer (B)

Sample Question 2: The class-mark of the class 130-150 is :

- (A) 130 (B) 135 (C) 140 (D) 145

Solution : Answer (C)

Sample Question 3 : A die is thrown 1000 times and the outcomes were recorded as follows :

Outcome	1	2	3	4	5	6
Frequency	180	150	160	170	150	190

If the die is thrown once more, then the probability that it shows 5 is :

- (A) $\frac{9}{50}$ (B) $\frac{3}{20}$ (C) $\frac{4}{25}$ (D) $\frac{7}{25}$

Solution : Answer (B)

EXERCISE 14.1

Write the correct answer in each of the following :

1. The class mark of the class 90-120 is :

- (A) 90 (B) 105 (C) 115 (D) 120

2. The range of the data :

25, 18, 20, 22, 16, 6, 17, 15, 12, 30, 32, 10, 19, 8, 11, 20 is

- (A) 10 (B) 15 (C) 18 (D) 26

3. In a frequency distribution, the mid value of a class is 10 and the width of the class is 6. The lower limit of the class is :

- (A) 6 (B) 7 (C) 8 (D) 12

4. The width of each of five continuous classes in a frequency distribution is 5 and the lower class-limit of the lowest class is 10. The upper class-limit of the highest class is:
 (A) 15 (B) 25 (C) 35 (D) 40
5. Let m be the mid-point and l be the upper class limit of a class in a continuous frequency distribution. The lower class limit of the class is :
 (A) $2m + l$ (B) $2m - l$ (C) $m - l$ (D) $m - 2l$
6. The class marks of a frequency distribution are given as follows :
 15, 20, 25, ...
 The class corresponding to the class mark 20 is :
 (A) 12.5 – 17.5 (B) 17.5 – 22.5 (C) 18.5 – 21.5 (D) 19.5 – 20.5
7. In the class intervals 10-20, 20-30, the number 20 is included in :
 (A) 10-20 (B) 20-30
 (C) both the intervals (D) none of these intervals
8. A grouped frequency table with class intervals of equal sizes using 250-270 (270 not included in this interval) as one of the class interval is constructed for the following data :
 268, 220, 368, 258, 242, 310, 272, 342,
 310, 290, 300, 320, 319, 304, 402, 318,
 406, 292, 354, 278, 210, 240, 330, 316,
 406, 215, 258, 236.
 The frequency of the class 310-330 is:
 (A) 4 (B) 5 (C) 6 (D) 7
9. A grouped frequency distribution table with classes of equal sizes using 63-72 (72 included) as one of the class is constructed for the following data :
 30, 32, 45, 54, 74, 78, 108, 112, 66, 76, 88,
 40, 14, 20, 15, 35, 44, 66, 75, 84, 95, 96,
 102, 110, 88, 74, 112, 14, 34, 44.
 The number of classes in the distribution will be :
 (A) 9 (B) 10 (C) 11 (D) 12
10. To draw a histogram to represent the following frequency distribution :

Class interval	5-10	10-15	15-25	25-45	45-75
Frequency	6	12	10	8	15

the adjusted frequency for the class 25-45 is :

- (A) 6 (B) 5 (C) 3 (D) 2

11. The mean of five numbers is 30. If one number is excluded, their mean becomes 28. The excluded number is :

- (A) 28 (B) 30 (C) 35 (D) 38

12. If the mean of the observations :

$x, x + 3, x + 5, x + 7, x + 10$

is 9, the mean of the last three observations is

- (A) $10\frac{1}{3}$ (B) $10\frac{2}{3}$ (C) $11\frac{1}{3}$ (D) $11\frac{2}{3}$

13. If \bar{x} represents the mean of n observations x_1, x_2, \dots, x_n , then value of $\sum_{i=1}^n (x_i - \bar{x})$ is:

- (A) -1 (B) 0 (C) 1 (D) $n - 1$

14. If each observation of the data is increased by 5, then their mean

- (A) remains the same (B) becomes 5 times the original mean
(C) is decreased by 5 (D) is increased by 5

15. Let \bar{x} be the mean of x_1, x_2, \dots, x_n and \bar{y} the mean of y_1, y_2, \dots, y_n . If \bar{z} is the mean of $x_1, x_2, \dots, x_n, y_1, y_2, \dots, y_n$, then \bar{z} is equal to

- (A) $\bar{x} + \bar{y}$ (B) $\frac{\bar{x} + \bar{y}}{2}$ (C) $\frac{\bar{x} + \bar{y}}{n}$ (D) $\frac{\bar{x} + \bar{y}}{2n}$

16. If \bar{x} is the mean of x_1, x_2, \dots, x_n , then for $a \neq 0$, the mean of $ax_1, ax_2, \dots, ax_n, \frac{x_1}{a},$

$\frac{x_2}{a}, \dots, \frac{x_n}{a}$ is

- (A) $\left(a + \frac{1}{a}\right)\bar{x}$ (B) $\left(a + \frac{1}{a}\right)\frac{\bar{x}}{2}$ (C) $\left(a + \frac{1}{a}\right)\frac{\bar{x}}{n}$ (D) $\frac{\left(a + \frac{1}{a}\right)\bar{x}}{2n}$

17. If $\bar{x}_1, \bar{x}_2, \bar{x}_3, \dots, \bar{x}_n$ are the means of n groups with n_1, n_2, \dots, n_n number of observations respectively, then the mean \bar{x} of all the groups taken together is given by :

$$(A) \sum_{i=1}^n n_i \bar{x}_i \quad (B) \frac{\sum_{i=1}^n n_i \bar{x}_i}{n^2} \quad (C) \frac{\sum_{i=1}^n n_i \bar{x}_i}{\sum_{i=1}^n n_i} \quad (D) \frac{\sum_{i=1}^n n_i \bar{x}_i}{2n}$$

18. The mean of 100 observations is 50. If one of the observations which was 50 is replaced by 150, the resulting mean will be :
 (A) 50.5 (B) 51 (C) 51.5 (D) 52
19. There are 50 numbers. Each number is subtracted from 53 and the mean of the numbers so obtained is found to be -3.5 . The mean of the given numbers is :
 (A) 46.5 (B) 49.5 (C) 53.5 (D) 56.5
20. The mean of 25 observations is 36. Out of these observations if the mean of first 13 observations is 32 and that of the last 13 observations is 40, the 13th observation is :
 (A) 23 (B) 36 (C) 38 (D) 40
21. The median of the data
 78, 56, 22, 34, 45, 54, 39, 68, 54, 84 is
 (A) 45 (B) 49.5 (C) 54 (D) 56
22. For drawing a frequency polygon of a continuous frequency distribution, we plot the points whose ordinates are the frequencies of the respective classes and abscissae are respectively :
 (A) upper limits of the classes (B) lower limits of the classes
 (C) class marks of the classes (D) upper limits of preceding classes
23. Median of the following numbers :
 4, 4, 5, 7, 6, 7, 7, 12, 3 is
 (A) 4 (B) 5 (C) 6 (D) 7
24. Mode of the data
 15, 14, 19, 20, 14, 15, 16, 14, 15, 18, 14, 19, 15, 17, 15 is
 (A) 14 (B) 15 (C) 16 (D) 17
25. In a sample study of 642 people, it was found that 514 people have a high school certificate. If a person is selected at random, the probability that the person has a high school certificate is :
 (A) 0.5 (B) 0.6 (C) 0.7 (D) 0.8

26. In a survey of 364 children aged 19-36 months, it was found that 91 liked to eat potato chips. If a child is selected at random, the probability that he/she does not like to eat potato chips is :

- (A) 0.25 (B) 0.50 (C) 0.75 (D) 0.80

27. In a medical examination of students of a class, the following blood groups are recorded:

Blood group	A	AB	B	O
Number of students	10	13	12	5

A student is selected at random from the class. The probability that he/she has blood group B, is :

- (A) $\frac{1}{4}$ (B) $\frac{13}{40}$ (C) $\frac{3}{10}$ (D) $\frac{1}{8}$

28. Two coins are tossed 1000 times and the outcomes are recorded as below :

Number of heads	2	1	0
Frequency	200	550	250

Based on this information, the probability for at most one head is

- (A) $\frac{1}{5}$ (B) $\frac{1}{4}$ (C) $\frac{4}{5}$ (D) $\frac{3}{4}$

29. 80 bulbs are selected at random from a lot and their life time (in hrs) is recorded in the form of a frequency table given below :

Life time (in hours)	300	500	700	900	1100
Frequency	10	12	23	25	10

One bulb is selected at random from the lot. The probability that its life is 1150 hours, is

- (A) $\frac{1}{80}$ (B) $\frac{7}{16}$ (C) 0 (D) 1

30. Refer to Q.29 above :

The probability that bulbs selected randomly from the lot has life less than 900 hours is :

- (A) $\frac{11}{40}$ (B) $\frac{5}{16}$ (C) $\frac{7}{16}$ (D) $\frac{9}{16}$

(C) Short Answer Questions with Reasoning

Sample Question 1 : The mean of the data :

2, 8, 6, 5, 4, 5, 6, 3, 6, 4, 9, 1, 5, 6, 5

is given to be 5. Based on this information, is it correct to say that the mean of the data:

10, 12, 10, 2, 18, 8, 12, 6, 12, 10, 8, 10, 12, 16, 4

is 10? Give reason.

Solution : It is correct. Since the 2nd data is obtained by multiplying each observation of 1st data by 2, therefore, the mean will be 2 times the mean of the 1st data.

Sample Question 2 : In a histogram, the areas of the rectangles are proportional to the frequencies. Can we say that the lengths of the rectangles are also proportional to the frequencies?

Solution: No. It is true only when the class sizes are the same.

Sample Question 3 : Consider the data : 2, 3, 9, 16, 9, 3, 9. Since 16 is the highest value in the observations, is it correct to say that it is the mode of the data? Give reason.

Solution : 16 is not the mode of the data. The mode of a given data is the observation with highest frequency and not the observation with highest value.

EXERCISE 14.2

1. The frequency distribution :

Marks	0-20	20-40	40-60	60-100
Number of Students	10	15	20	25

has been represented graphically as follows :

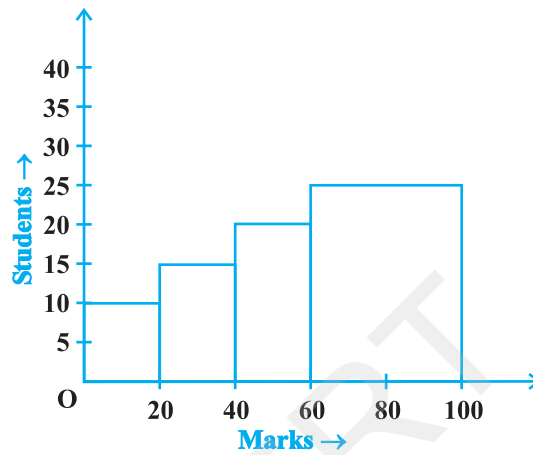

Fig. 14.1

Do you think this representation is correct? Why?

2. In a diagnostic test in mathematics given to students, the following marks (out of 100) are recorded:

46, 52, 48, 11, 41, 62, 54, 53, 96, 40, 98, 44

Which 'average' will be a good representative of the above data and why?

3. A child says that the median of 3, 14, 18, 20, 5 is 18. What doesn't the child understand about finding the median?

4. A football player scored the following number of goals in the 10 matches :

1, 3, 2, 5, 8, 6, 1, 4, 7, 9

Since the number of matches is 10 (an even number), therefore, the median

$$= \frac{5^{\text{th}} \text{ observation} + 6^{\text{th}} \text{ observation}}{2}$$

$$= \frac{8+6}{2} = 7$$

Is it the correct answer and why?

5. Is it correct to say that in a histogram, the area of each rectangle is proportional to the class size of the corresponding class interval? If not, correct the statement.

6. The class marks of a continuous distribution are :

1.04, 1.14, 1.24, 1.34, 1.44, 1.54 and 1.64

Is it correct to say that the last interval will be 1.55 - 1.73? Justify your answer.

7. 30 children were asked about the number of hours they watched TV programmes last week. The results are recorded as under :

Number of hours	0-5	5-10	10-15	15-20
Frequency	8	16	4	2

Can we say that the number of children who watched TV for 10 or more hours a week is 22? Justify your answer.

8. Can the experimental probability of an event be a negative number? If not, why?
 9. Can the experimental probability of an event be greater than 1? Justify your answer.
 10. As the number of tosses of a coin increases, the ratio of the number of heads to the total number of tosses will be $\frac{1}{2}$. Is it correct? If not, write the correct one.

(D) Short Answer Questions

Sample Question 1 : Heights (in cm) of 30 girls of Class IX are given below:

140, 140, 160, 139, 153, 153, 146, 150, 148, 150, 152,
 146, 154, 150, 160, 148, 150, 148, 140, 148, 153, 138,
 152, 150, 148, 138, 152, 140, 146, 148.

Prepare a frequency distribution table for this data.

Solution : Frequency distribution of heights of 30 girls

Height (in cm)	Tally Marks	Frequency
138		2
139		1
140		4
146		3
148	 	6
150	 	5
152		3
153		3
154		1
160		2
Total		30

Sample Question 2 : The following observations are arranged in ascending order :
26, 29, 42, 53, x , $x + 2$, 70, 75, 82, 93

If the median is 65, find the value of x .

Solution : Number of observations (n) = 10, which is even. Therefore, median is the mean of $\left(\frac{n}{2}\right)^{\text{th}}$ and $\left(\frac{n}{2} + 1\right)^{\text{th}}$ observation, i.e., 5th and 6th observation.

Here, 5^{th} observation = x
 6^{th} observation = $x + 2$

$$\text{Median} = \frac{x + (x + 2)}{2} = x + 1$$

Now, $x + 1 = 65$ (Given)
Therefore, $x = 64$

Thus, the value of x is 64.

Sample Question 3 : Here is an extract from a mortality table.

Age (in years)	Number of persons surviving out of a sample of one million
60	16090
61	11490
62	8012
63	5448
64	3607
65	2320

- Based on this information, what is the probability of a person 'aged 60' of dying within a year?
- What is the probability that a person 'aged 61' will live for 4 years?

Solution :

- We see that 16090 persons aged 60, (16090-11490), i.e., 4600 died before reaching their 61st birthday.

$$\text{Therefore, } P(\text{a person aged 60 die within a year}) = \frac{4600}{16090} = \frac{460}{1609}$$

- (ii) Number of persons aged 61 years = 11490
 Number of persons surviving for 4 years = 2320

$$P(\text{a person aged 61 will live for 4 years}) = \frac{2320}{11490} = \frac{232}{1149}$$

EXERCISE 14.3

- The blood groups of 30 students are recorded as follows:
 A, B, O, A, AB, O, A, O, B, A, O, B, A, AB, B, A, AB, B,
 A, A, O, A, AB, B, A, O, B, A, B, A
 Prepare a frequency distribution table for the data.
- The value of π upto 35 decimal places is given below:
 3.14159265358979323846264338327950288
 Make a frequency distribution of the digits 0 to 9 after the decimal point.
- The scores (out of 100) obtained by 33 students in a mathematics test are as follows:
 69, 48, 84, 58, 48, 73, 83, 48, 66, 58, 84
 66, 64, 71, 64, 66, 69, 66, 83, 66, 69, 71
 81, 71, 73, 69, 66, 66, 64, 58, 64, 69, 69
 Represent this data in the form of a frequency distribution.
- Prepare a continuous grouped frequency distribution from the following data:

Mid-point	Frequency
5	4
15	8
25	13
35	12
45	6

Also find the size of class intervals.

- Convert the given frequency distribution into a continuous grouped frequency distribution:

Class interval	Frequency
150-153	7
154-157	7
158-161	15
162-165	10
166-169	5
170-173	6

In which intervals would 153.5 and 157.5 be included?

6. The expenditure of a family on different heads in a month is given below:

Head	Food	Education	Clothing	House Rent	Others	Savings
Expenditure (in Rs)	4000	2500	1000	3500	2500	1500

Draw a bar graph to represent the data above.

7. Expenditure on Education of a country during a five year period (2002-2006), in crores of rupees, is given below:

Elementary education	240
Secondary Education	120
University Education	190
Teacher's Training	20
Social Education	10
Other Educational Programmes	115
Cultural programmes	25
Technical Education	125

Represent the information above by a bar graph.

8. The following table gives the frequencies of most commonly used letters a, e, i, o, r, t, u from a page of a book :

Letters	a	e	i	o	r	t	u
Frequency	75	125	80	70	80	95	75

Represent the information above by a bar graph.

9. If the mean of the following data is 20.2, find the value of p :

x	10	15	20	25	30
f	6	8	p	10	6

10. Obtain the mean of the following distribution:

Frequency	Variable
4	4
8	6
14	8
11	10
3	12

11. A class consists of 50 students out of which 30 are girls. The mean of marks scored by girls in a test is 73 (out of 100) and that of boys is 71. Determine the mean score of the whole class.
12. Mean of 50 observations was found to be 80.4. But later on, it was discovered that 96 was misread as 69 at one place. Find the correct mean.
13. Ten observations 6, 14, 15, 17, $x + 1$, $2x - 13$, 30, 32, 34, 43 are written in an ascending order. The median of the data is 24. Find the value of x .
14. The points scored by a basket ball team in a series of matches are as follows:
17, 2, 7, 27, 25, 5, 14, 18, 10, 24, 48, 10, 8, 7, 10, 28
Find the median and mode for the data.
15. In Fig. 14.2, there is a histogram depicting daily wages of workers in a factory. Construct the frequency distribution table.

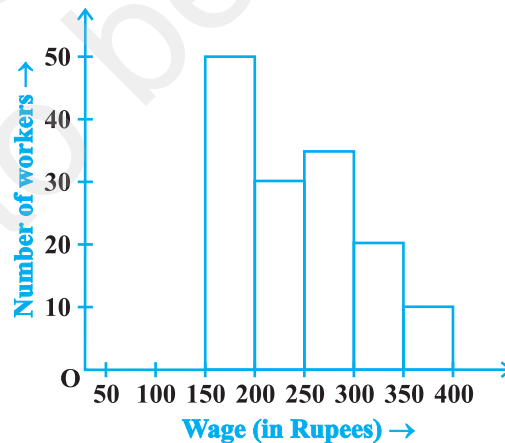

Fig. 14.2

16. A company selected 4000 households at random and surveyed them to find out a relationship between income level and the number of television sets in a home. The information so obtained is listed in the following table:

Monthly income (in Rs)	Number of Televisions/household			
	0	1	2	Above 2
< 10000	20	80	10	0
10000 - 14999	10	240	60	0
15000 - 19999	0	380	120	30
20000 - 24999	0	520	370	80
25000 and above	0	1100	760	220

Find the probability:

- of a household earning Rs 10000 – Rs 14999 per year and having exactly one television.
 - of a household earning Rs 25000 and more per year and owning 2 televisions.
 - of a household not having any television.
17. Two dice are thrown simultaneously 500 times. Each time the sum of two numbers appearing on their tops is noted and recorded as given in the following table:

Sum	Frequency
2	14
3	30
4	42
5	55
6	72
7	75
8	70
9	53
10	46
11	28
12	15

If the dice are thrown once more, what is the probability of getting a sum

- (i) 3? (ii) more than 10?
 (iii) less than or equal to 5? (iv) between 8 and 12?

18. Bulbs are packed in cartons each containing 40 bulbs. Seven hundred cartons were examined for defective bulbs and the results are given in the following table:

Number of defective bulbs	0	1	2	3	4	5	6	more than 6
Frequency	400	180	48	41	18	8	3	2

One carton was selected at random. What is the probability that it has

- (i) no defective bulb?
 (ii) defective bulbs from 2 to 6?
 (iii) defective bulbs less than 4?
19. Over the past 200 working days, the number of defective parts produced by a machine is given in the following table:

Number of defective parts	0	1	2	3	4	5	6	7	8	9	10	11	12	13
Days	50	32	22	18	12	12	10	10	10	8	6	6	2	2

Determine the probability that tomorrow's output will have

- (i) no defective part
 (ii) atleast one defective part
 (iii) not more than 5 defective parts
 (iv) more than 13 defective parts
20. A recent survey found that the ages of workers in a factory is distributed as follows:

Age (in years)	20 - 29	30 - 39	40 - 49	50 - 59	60 and above
Number of workers	38	27	86	46	3

If a person is selected at random, find the probability that the person is:

- (i) 40 years or more
 (ii) under 40 years

- (iii) having age from 30 to 39 years
- (iv) under 60 but over 39 years

(E) Long Answer Questions

Sample Question 1: Following is the frequency distribution of total marks obtained by the students of different sections of Class VIII.

Marks	100 - 150	150 - 200	200 - 300	300 - 500	500 - 800
Number of students	60	100	100	80	180

Draw a histogram for the distribution above.

Solution: In the given frequency distribution, the class intervals are not of equal width.

Therefore, we would make modifications in the lengths of the rectangles in the histogram so that the areas of rectangles are proportional to the frequencies. Thus, we have:

Marks	Frequency	Width of the class	Length of the rectangle
100 - 150	60	50	$\frac{50}{50} \times 60 = 60$
150 - 200	100	50	$\frac{50}{50} \times 100 = 100$
200 - 300	100	100	$\frac{50}{100} \times 100 = 50$
300 - 500	80	200	$\frac{50}{200} \times 80 = 20$
500 - 800	180	300	$\frac{50}{300} \times 180 = 30$

Now, we draw rectangles with lengths as given in the last column. The histogram of the data is given below :

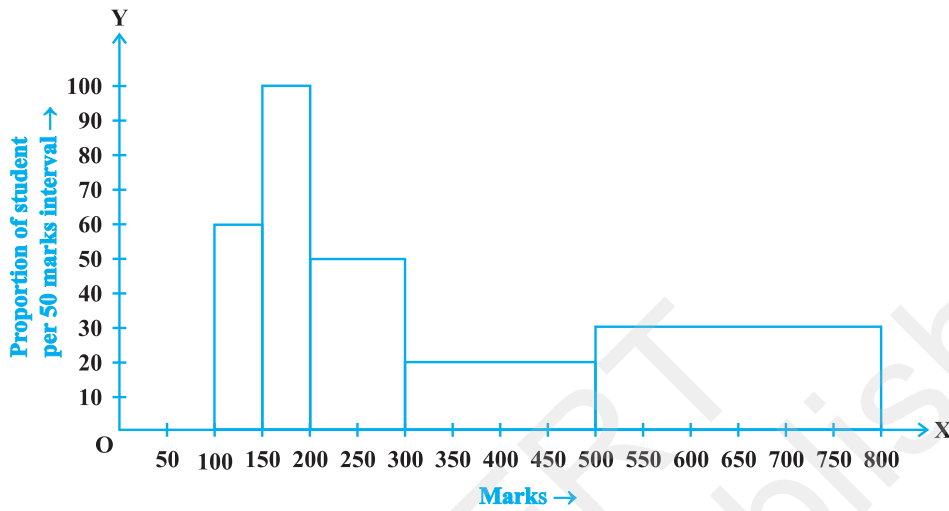

Fig. 14.3

Sample Question 2 : Two sections of Class IX having 30 students each appeared for mathematics olympiad. The marks obtained by them are shown below:

46 31 74 68 42 54 14 61 83 48 37 26 8 64 57
 93 72 53 59 38 16 88 75 56 46 66 45 61 54 27
 27 44 63 58 43 81 64 67 36 49 50 76 38 47 55
 77 62 53 40 71 60 58 45 42 34 46 40 59 42 29

Construct a group frequency distribution of the data above using the classes 0-9, 10-19 etc., and hence find the number of students who secured more than 49 marks.

Solution :

Class	Tally Marks	Frequency
0-9		1
10-19		2
20-29		4
30-39	 	6
40-49	 	15
50-59	 	12
60-69	 	10
70-79	 	6
80-89		3
90-99		1
Total		60

From the table above, we find that the number of students who secure more than 49 marks is $(12 + 10 + 6 + 3 + 1)$, i.e., 32.

EXERCISE 14.4

1. The following are the marks (out of 100) of 60 students in mathematics.

16, 13, 5, 80, 86, 7, 51, 48, 24, 56, 70, 19, 61, 17, 16, 36, 34, 42, 34, 35, 72, 55, 75, 31, 52, 28, 72, 97, 74, 45, 62, 68, 86, 35, 85, 36, 81, 75, 55, 26, 95, 31, 7, 78, 92, 62, 52, 56, 15, 63, 25, 36, 54, 44, 47, 27, 72, 17, 4, 30.

Construct a grouped frequency distribution table with width 10 of each class starting from 0 - 9.

2. Refer to Q1 above. Construct a grouped frequency distribution table with width 10 of each class, in such a way that one of the classes is 10 - 20 (20 not included).
3. Draw a histogram of the following distribution :

Heights (in cm)	Number of students
150 - 153	7
153 - 156	8
156 - 159	14
159 - 162	10
162 - 165	6
165 - 168	5

4. Draw a histogram to represent the following grouped frequency distribution :

Ages (in years)	Number of teachers
20 - 24	10
25 - 29	28
30 - 34	32
35 - 39	48
40 - 44	50
45 - 49	35
50 - 54	12

5. The lengths of 62 leaves of a plant are measured in millimetres and the data is represented in the following table :

Length (in mm)	Number of leaves
118 - 126	8
127 - 135	10
136 - 144	12
145 - 153	17
154 - 162	7
163 - 171	5
172 - 180	3

Draw a histogram to represent the data above.

6. The marks obtained (out of 100) by a class of 80 students are given below :

Marks	Number of students
10 - 20	6
20 - 30	17
30 - 50	15
50 - 70	16
70 - 100	26

Construct a histogram to represent the data above.

7. Following table shows a frequency distribution for the speed of cars passing through at a particular spot on a high way :

Class interval (km/h)	Frequency
30 - 40	3
40 - 50	6
50 - 60	25
60 - 70	65
70 - 80	50
80 - 90	28
90 - 100	14

Draw a histogram and frequency polygon representing the data above.

8. Refer to Q. 7 :

Draw the frequency polygon representing the above data without drawing the histogram.

9. Following table gives the distribution of students of sections A and B of a class according to the marks obtained by them.

Section A		Section B	
Marks	Frequency	Marks	Frequency
0 - 15	5	0 - 15	3
15 - 30	12	15 - 30	16
30 - 45	28	30 - 45	25
45 - 60	30	45 - 60	27
60 - 75	35	60 - 75	40
75 - 90	13	75 - 90	10

Represent the marks of the students of both the sections on the same graph by two frequency polygons. What do you observe?

10. The mean of the following distribution is 50.

x	f
10	17
30	$5a + 3$
50	32
70	$7a - 11$
90	19

Find the value of a and hence the frequencies of 30 and 70.

11. The mean marks (out of 100) of boys and girls in an examination are 70 and 73, respectively. If the mean marks of all the students in that examination is 71, find the ratio of the number of boys to the number of girls.

12. A total of 25 patients admitted to a hospital are tested for levels of blood sugar, (mg/dl) and the results obtained were as follows :

87	71	83	67	85
77	69	76	65	85
85	54	70	68	80
73	78	68	85	73
81	78	81	77	75

Find mean, median and mode (mg/dl) of the above data.

DESIGN OF THE QUESTION PAPER

MATHEMATICS – CLASS IX

Time : 3 Hours

Maximum Marks : 80

The weightage or the distribution of marks over different dimensions of the question paper shall be as follows:

1. Weightage to Content/ Subject Units

S.No.	Units	Marks
1.	Number Systems	06
2.	Algebra	20
3.	Coordinate Geometry	06
4.	Geometry	22
5.	Mensuration	14
6.	Statistics and Probability	12

2. Weightage to Forms of Questions

S.No.	Forms of Questions	Marks for each Question	Number of Questions	Total Marks
1.	MCQ	01	10	10
2.	SAR	02	05	10
3.	SA	03	10	30
4.	LA	06	05	30
Total			30	80

3. Scheme of Options

All questions are compulsory, i.e., there is no overall choice. However, internal choices are provided in two questions of 3 marks each and 1 question of 6 marks.

4. Weightage to Difficulty level of Questions

S.No.	Estimated Difficulty Level of Questions	Percentage of Marks
1.	Easy	20
2.	Average	60
3.	Difficult	20

Note

A question may vary in difficulty level from individual to individual. As such, the assessment in respect of each question will be made by the paper setter/ teacher on the basis of general anticipation from the groups as whole taking the examination. This provision is only to make the paper balanced in its weight, rather to determine the pattern of marking at any stage.

BLUE PRINT
MATHEMATICS – CLASS IX

Forms of Questions → Content Units ↓	MCQ	SAR	SA	LA	Total
NUMBER SYSTEMS	1 (1)	2 (1)	3 (1)	–	6 (3)
ALGEBRA Polynomials, Linear Equations in Two Variables	1 (1)	4 (2)	9 (3)	6 (1)	20 (7)
COORDINATE GEOMETRY	1 (1)	2 (1)	3 (1)	–	6 (3)
GEOMETRY Introduction to Euclid's Geometry, Lines and Angles, Triangles, Quadrilaterals, Areas, Circles, Constructions	4 (4)	–	6 (2)	12 (2)	22 (8)
MENSURATION Areas, Surface areas and Volumes	2 (2)	–	6 (2)	6 (1)	14 (5)
STATISTICS AND PROBABILITY Statistics, Probability	1 (1)	2 (1)	3 (1)	6 (1)	12 (4)
Total	10 (10)	10 (05)	30 (10)	30 (05)	80 (30)

SUMMARY

Multiple Choice Questions (MCQ)	Number of Questions: 10	Marks: 10
Short Answer with Reasoning (SAR)	Number of Questions: 05	Marks: 10
Short Answer (SA)	Number of Questions: 10	Marks: 30
Long Answer (LA)	Number of Questions: 05	Marks: 30
Total	30	80

MATHEMATICS
CLASS IX

Time: 3 hours

Maximum Marks: 80

General Instructions

- All questions are compulsory.
- The question paper consists of four sections A, B, C and D. Section A has 10 questions of 1 mark each, section B has 5 questions of 2 marks each, section C has 10 questions of 3 marks each and section D is of 5 questions of 6 marks each.
- There is no overall choice. However internal choices are provided in 2 questions of 3 marks each and 1 question of 6 marks.
- Construction should be drawn neatly and exactly as per the given measurements.
- Use of calculators is not allowed.

SECTION A

In Questions 1 to 10, four options of answer are given in each, out of which only one is correct. Write the correct option.

- Every rational number is:

(A) a natural number	(B) an integer
(C) a real number	(D) a whole number
- The distance of point (2, 4) from x -axis is

(A) 2 units	(B) 4 units	(C) 6 units	(D) $\sqrt{2^2 + 4^2}$ units
-------------	-------------	-------------	------------------------------
- The degree of the polynomial $(x^3 + 7)(3 - x^2)$ is:

(A) 5	(B) 3
(C) 2	(D) -5
- In Fig. 1, according to Euclid's 5th postulate, the pair of angles, having the sum less than 180° is:

(A) 1 and 2	(B) 2 and 4
(C) 1 and 3	(D) 3 and 4
- The length of the chord which is at a distance of 12 cm from the centre of a circle of radius 13cm is:

(A) 5 cm	(B) 12 cm
(C) 13 cm	(D) 10 cm

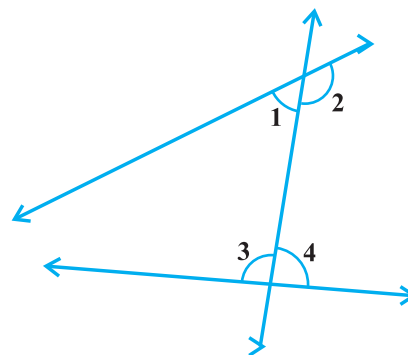

Fig. 1

6. If the volume of a sphere is numerically equal to its surface area, then its diameter is:
 (A) 2 units (B) 1 units (C) 3 units (D) 6 units
7. Two sides of a triangle are 5 cm and 13 cm and its perimeter is 30 cm. The area of the triangle is:
 (A) 30 cm^2 (B) 60 cm^2 (C) 32.5 cm^2 (D) 65 cm^2
8. Which of the following cannot be the empirical probability of an event.
 (A) $\frac{2}{3}$ (B) $\frac{3}{2}$ (C) 0 (D) 1
9. In Fig. 2, if $l \parallel m$, then the value of x is:
 (A) 60 (B) 80
 (C) 40 (D) 140
10. The diagonals of a parallelogram :
 (A) are equal
 (B) bisect each other
 (C) are perpendicular to each other
 (D) bisect each other at right angles.

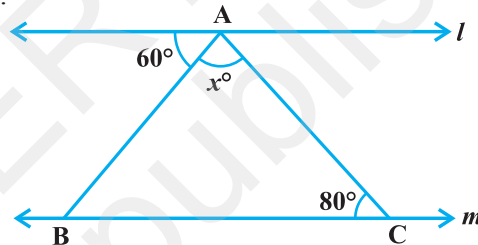

Fig. 2

SECTION B

11. Is -5 a rational number? Give reasons to your answer.
12. Without actually finding $p(5)$, find whether $(x-5)$ is a factor of $p(x) = x^3 - 7x^2 + 16x - 12$. Justify your answer.
13. Is $(1, 8)$ the only solution of $y = 3x + 5$? Give reasons.
14. Write the coordinates of a point on x -axis at a distance of 4 units from origin in the positive direction of x -axis and then justify your answer.
15. Two coins are tossed simultaneously 500 times. If we get two heads 100 times, one head 270 times and no head 130 times, then find the probability of getting one or more than one head. Give reasons to your answer also.

SECTION C

16. Simplify the following expression

$$(\sqrt{3} + 1)(1 - \sqrt{12}) + \frac{9}{\sqrt{3} + \sqrt{12}}$$

OR

Express $0.12\bar{3}$ in the form of $\frac{p}{q}$, $q \neq 0$, p and q are integers.

17. Verify that:

$$x^3 + y^3 + z^3 - 3xyz = \frac{1}{2}(x+y+z)[(x-y)^2 + (y-z)^2 + (z-x)^2]$$

18. Find the value of k , if $(x-2)$ is a factor of $4x^3 + 3x^2 - 4x + k$.

19. Write the quadrant in which each of the following points lie :

- (i) $(-3, -5)$
- (ii) $(2, -5)$
- (iii) $(-3, 5)$

Also, verify by locating them on the cartesian plane.

20. In Figure 3, ABC and ABD are two triangles on the same base AB.

If the line segment CD is bisected by AB at O, then show that:

$$\text{area}(\Delta ABC) = \text{area}(\Delta ABD)$$

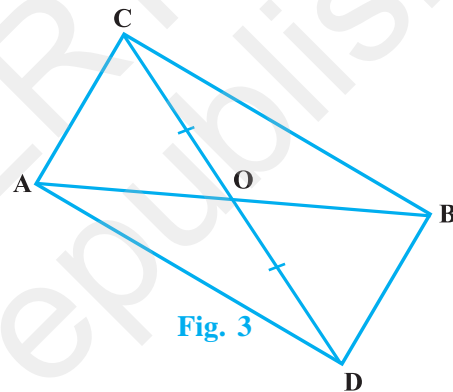

21. Solve the equation $3x + 2 = 2x - 2$ and represent the solution on the cartesian plane.

22. Construct a right triangle whose base is 12 cm and the difference in lengths of its hypotenuse and the other side is 8 cm. Also give justification of the steps of construction.

23. In a quadrilateral ABCD, $AB = 9$ cm, $BC = 12$ cm, $CD = 5$ cm, $AD = 8$ cm and $\angle C = 90^\circ$. Find the area of ΔABD

24. In a hot water heating system, there is a cylindrical pipe of length 35 m and diameter 10 cm. Find the total radiating surface in the system.

OR

The floor of a rectangular hall has a perimeter 150 m. If the cost of painting the four walls at the rate of Rs 10 per m^2 is Rs 9000, find the height of the hall.

25. Three coins are tossed simultaneously 200 times with the following frequencies of different outcomes:

Outcome	3 tails	2 tails	1 tail	no tail
Frequency	20	68	82	30

If the three coins are simultaneously tossed again, compute the probability of getting less than 3 tails.

SECTION D

26. The taxi fair in a city is as follows:

For the first kilometer, the fare is Rs 10 and for the subsequent distance it is Rs 6 per km. Taking the distance covered as x km and total fare as Rs y , write a linear equation for this information and draw its graph.

From the graph, find the fare for travelling a distance of 4 km.

27. Prove that the angles opposite to equal sides of an isosceles triangle are equal.

Using the above, find $\angle B$ in a right triangle ABC, right angled at A with $AB = AC$.

28. Prove that the angle subtended by an arc at the centre is double the angle subtended by it at any point on the remaining part of the circle.

Using the above result, find x in figure 4 where O is the centre of the circle.

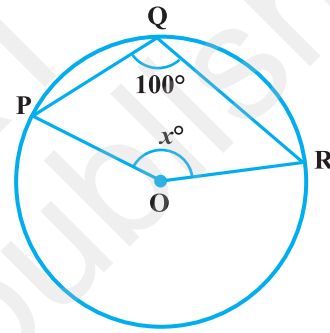

Fig. 4

29. A heap of wheat is in the form of a cone whose diameter is 48 m and height is 7 m. Find its volume. If the heap is to be covered by canvas to protect it from rain, find the area of the canvas required.

OR

A dome of a building is in the form of a hollow hemisphere. From inside, it was white-washed at the cost of Rs 498.96. If the rate of white washing is Rs 2.00 per square meter, find the volume of air inside the dome.

30. The following table gives the life times of 400 neon lamps:

Life time (in hours)	300-400	400-500	500-600	600-700	700-800	800-900	900-1000
Number of Lamps	14	56	60	86	74	62	48

- Represent the given information with the help of a histogram.
- How many lamps have a lifetime of less than 600 hours?

Marking Scheme

MATHEMATICS– CLASS IX

SECTION A

MARKS

1. (C)	2. (B)	3. (A)	4. (C)	5. (D)
6. (D)	7. (A)	8. (B)	9. (C)	10. (B)
(1 × 10 = 10)				

SECTION B

11. Yes,	($\frac{1}{2}$)
since $-5 = \frac{-5}{1}$ and $-5, 1$ are integers and $1 \neq 0$.	($1\frac{1}{2}$)
12. $(x - 5)$ is not a factor of $p(x)$,	($\frac{1}{2}$)
since, 5 is not a factor of -12	($1\frac{1}{2}$)
13. No,	($\frac{1}{2}$)
since, $y = 3x + 5$ have many solutions like $(-1, 2), (2, 11)$ etc.	($1\frac{1}{2}$)
14. $(4, 0)$	($\frac{1}{2}$)
since, any point on x -axis have coordinates $(x, 0)$, where x is the distance from origin.	($1\frac{1}{2}$)
15. $p = \frac{37}{50}$	($\frac{1}{2}$)

Since, frequency of one or more than one head = $100 + 270 = 370$

$$\text{Therefore, } P(\text{one or more Heads}) = \frac{370}{500} = \frac{37}{50} \quad \left(1 \frac{1}{2}\right)$$

SECTION C

$$\begin{aligned} 16. & (\sqrt{3}+1)(1-\sqrt{12}) + \frac{9}{\sqrt{3}+\sqrt{12}} \\ & = (\sqrt{3}-\sqrt{36}+1-\sqrt{12}) + \frac{9}{\sqrt{12}+\sqrt{3}} \cdot \frac{\sqrt{12}-\sqrt{3}}{\sqrt{12}-\sqrt{3}} \quad (1) \\ & = (\sqrt{3}-5-\sqrt{12}) + \frac{9(\sqrt{12}-\sqrt{3})}{(12-3)} \quad (1) \\ & = (\sqrt{3}-5-\sqrt{12}) + (\sqrt{12}-\sqrt{3}) = -5. \quad (1) \end{aligned}$$

OR

Let $x = 0.12\bar{3} = 0.123333\dots$

$$\text{Therefore, } 100x = 12.\bar{3} \quad (1)$$

$$\text{and } 1000x = 123.\bar{3} \quad \left(\frac{1}{2}\right)$$

$$\text{Therefore, } 900x = 111, \text{ i.e., } x = \frac{111}{900} \quad \left(1 \frac{1}{2}\right)$$

$$\begin{aligned} 17. \text{ LHS} & = x^3 + y^3 + z^3 - 3xyz \\ & = (x+y+z)(x^2 + y^2 + z^2 - xy - yz - zx) \quad (1) \\ & = \frac{1}{2}(x+y+z)(2x^2 + 2y^2 + 2z^2 - 2xy - 2yz - 2zx) \quad \left(\frac{1}{2}\right) \\ & = \frac{1}{2}(x+y+z)\left[(x^2 + y^2 - 2xy) + (x^2 + z^2 - 2xy) + (y^2 + z^2 - 2xz)\right] \quad (1) \\ & = \frac{1}{2}(x+y+z)\left[(x-y)^2 + (z-x)^2 + (y-z)^2\right] \quad \left(\frac{1}{2}\right) \end{aligned}$$

18. When $(x-2)$ is a factor of $p(x) = 4x^3 + 3x^2 - 4x + k$, then $p(2) = 0$ (1)

Therefore, $4(2)^3 + 3(2)^2 - 4(2) + k = 0$ (1)

or $32 + 12 - 8 + k = 0$, i.e., $k = -36$ (1)

19. $(-3, -5)$ lies in 3rd Quadrant

$(2, -5)$ lies in 4th Quadrant

$(-3, 5)$ lies in 2nd Quadrant

For correctly

locating the points

$$\left(\frac{1}{2} \times 3 = 1\frac{1}{2}\right)$$

$$\left(\frac{1}{2} \times 3 = 1\frac{1}{2}\right)$$

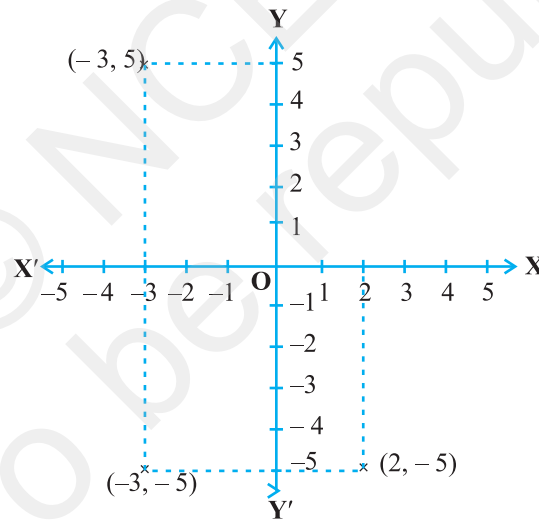

20. Draw $CL \perp AB$ and $DM \perp AB$

$$\triangle COL \cong \triangle DOM \text{ (AAS)}$$

Therefore, $CL = DM$

$$\left(\frac{1}{2}\right)$$

$$\left(\frac{1}{2}\right)$$

$$\left(\frac{1}{2}\right)$$

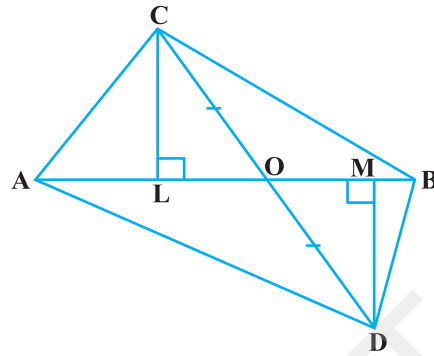

$$\begin{aligned} \text{Therefore, Area } (\Delta ABC) &= \frac{1}{2} AB \cdot CL && \left(\frac{1}{2}\right) \\ &= \frac{1}{2} AB \cdot DM && \left(\frac{1}{2}\right) \\ &= \text{Area } (\Delta ABD) && \left(\frac{1}{2}\right) \end{aligned}$$

21. $3x + 2 = 2x - 2$
 i.e., $3x - 2x = -2 - 2$, i.e., $x = -4$ (1)

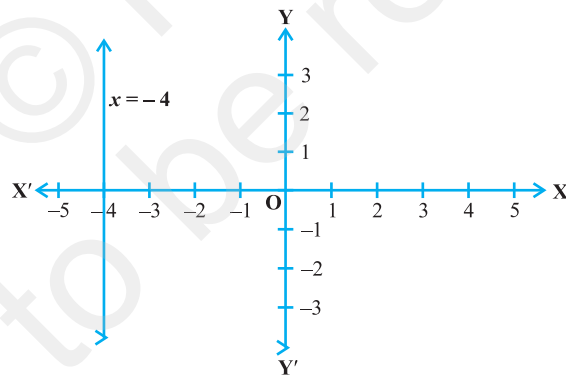

22. For correct geometrical construction (2)
 For Justification (1)

23. Getting $BD = \sqrt{12^2 + 5^2} = 13$ cm (1)

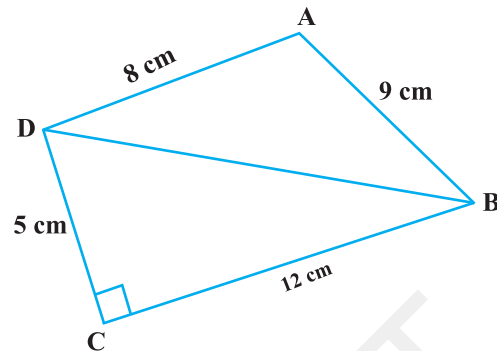

$$S = \frac{13+9+8}{2} = 15 \text{ cm} \quad \left(\frac{1}{2}\right)$$

$$\Delta ABD = \sqrt{(15)(15-13)(15-8)(15-9)}$$

$$= \sqrt{840} = 28.98 \text{ cm}^2$$

$$= 29 \text{ cm}^2 \text{ (approx)} \quad \left(\frac{1}{2}\right)$$

24. Radiating surface = curved surface of cylinder

$$= 2\pi rh \quad \left(\frac{1}{2}\right)$$

$$= 2 \cdot \frac{22}{7} \cdot \frac{5}{100} \cdot 35 \text{ m}^2 \quad \left(1\frac{1}{2}\right)$$

$$= 11 \text{ m}^2 \quad \left(\frac{1}{2}\right)$$

OR

If l, b represent the length, breadth of the hall, respectively,

$$\text{then } 2(l+b) = 150 \text{ m} \quad \left(\frac{1}{2}\right)$$

$$\text{Area of four walls} = 2(l+b)h, \text{ where } h \text{ is the height} \quad (1)$$

$$\text{Therefore, } 2(l+b)h \cdot 10 = 9000 \quad \left(\frac{1}{2}\right)$$

or $(150)h(10) = 9000$, i.e., $h = 6$ m

Therefore, height of the hall = 6 m (1)

25. Total number of trials = 200 $(\frac{1}{2})$

Frequency of the outcomes, less than 3 trials,
= $68 + 82 + 30 = 180$ (1)

Therefore, required probability = $\frac{180}{200} = \frac{9}{10}$ $(1\frac{1}{2})$

SECTION D

26. Let the distance covered be x km
and total fare for x km = Rs y

Therefore, $10 + 6(x - 1) = y$ (2)

or $6x - y + 4 = 0$ (1)

x	0	1	2
y	4	10	16

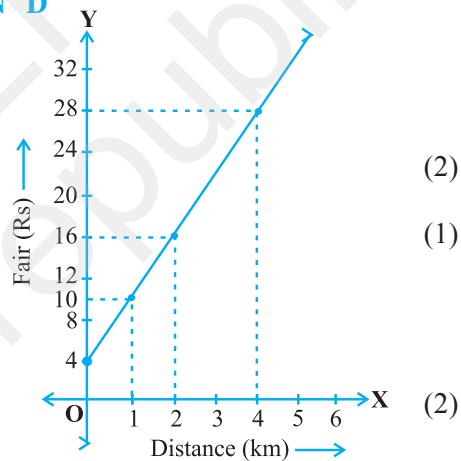

From the graph, when $x = 4$, $y = 28$ (2)
Therefore, fare is Rs 28 for a distance of 4 km. (1)

27. For correct given, to prove, construction and figure $(\frac{1}{2} \times 4 = 2)$

For correct proof (2)

Since, $\angle B = 90^\circ$, therefore, $\angle A + \angle C = 90^\circ$ $(\frac{1}{2})$

$AB = AC$ gives $\angle A = \angle C$ (1)

Therefore, $\angle A = \angle C = 45^\circ$ $(\frac{1}{2})$

28. For correct given, to prove, construction and figure

$$\left(\frac{1}{2} \times 4 = 2\right)$$

For correct proof

Since $\angle PQR = 100^\circ$

Therefore, $\angle y = 200^\circ$

Since $\angle x + \angle y = 360^\circ$

Therefore, $\angle x = 360^\circ - 200^\circ = 160^\circ$

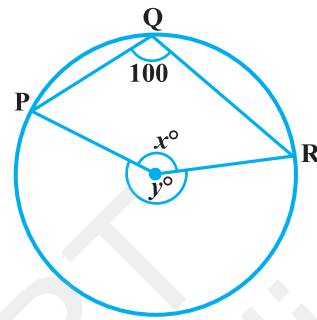

(2)

(1)

 $\left(\frac{1}{2}\right)$ $\left(\frac{1}{2}\right)$

29. Radius of conical heap = 24 m

Height = 7 m

$$\text{Volume} = \frac{1}{3} \pi r^2 h$$

$$= \frac{1}{3} \cdot \frac{22}{7} \cdot 24 \cdot 24 \cdot 7 \text{ m}^3$$

$$= 4224 \text{ m}^3$$

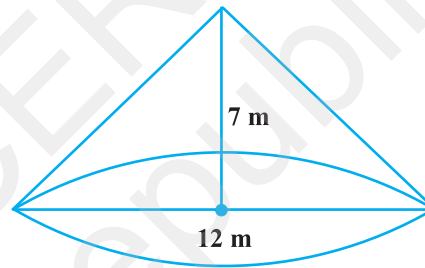

(1)

 $\left(1 \frac{1}{2}\right)$

Area of canvas = curved surface area of cone = $\pi r l$

 $\left(\frac{1}{2}\right)$

$$\text{where } l = \sqrt{r^2 + h^2} = \sqrt{24^2 + 7^2} = \sqrt{625} = 25 \text{ m}$$

(1)

$$\text{Therefore, Area} = \frac{22}{7} \times 24 \times 25 = 1885.7 \text{ m}^2$$

(2)

OR

Total cost = Rs 498.96, rate = Rs 2 per m^2

$$\text{Therefore, Area} = \frac{498.96}{2} = 249.48 \text{ m}^2$$

(1 + 1 = 2)

If r is the radius, then,

$$2\pi r^2 = 249.47, \text{ i.e., } r^2 = 249.48 \times \frac{1}{2} \times \frac{7}{22} \quad (1)$$

$$\text{i.e., } r^2 = \frac{567 \times 7}{100} \text{ which gives } r = 6.3 \text{ m} \quad (1)$$

$$\text{Therefore, volume of dome} = \frac{2}{3}\pi r^3 = \frac{2}{3} \cdot \frac{22}{7} \cdot \left(\frac{63}{10}\right)^3 \quad (1)$$

$$= 523.91 \text{ m}^3 \quad (1)$$

30. For correctly making the histogram (4)

No. of lamps having life time less than 600

$$= 14 + 56 + 60 = 130 \quad (2)$$

DESIGN OF THE QUESTION PAPER

MATHEMATICS – CLASS IX

Time : 3 Hours

Maximum Marks : 80

The weightage or the distribution of marks over different dimensions of the question paper shall be as follows:

1. Weightage to Content/ Subject Units

S.No.	Units	Marks
1.	Number Systems	06
2.	Algebra	20
3.	Coordinate Geometry	06
4.	Geometry	22
5.	Mensuration	14
6.	Statistics and Probability	12

2 Weightage to Forms of Questions

S.No.	Forms of Questions	Marks for each Question	Number of Questions	Total Marks
1.	MCQ	01	10	10
2.	SAR	02	05	10
3.	SA	03	10	30
4.	LA	06	05	30
Total			30	80

3. Scheme of Options

All questions are compulsory, i.e., there is no overall choice. However, internal choices are provided in two questions of 3 marks each and 1 question of 6 marks.

4. Weightage to Difficulty Level of Questions

S.No.	Estimated Difficulty Level of Questions	Percentage of Marks
1.	Easy	20
2.	Average	60
3.	Difficult	20

Note

A question may vary in difficulty level from individual to individual. As such, the assessment in respect of each question will be made by the paper setter/ teacher on the basis of general anticipation from the groups as whole taking the examination. This provision is only to make the paper balanced in its weight, rather to determine the pattern of marking at any stage.

BLUE PRINT
MATHEMATICS – CLASS IX

Forms of Questions → Content Units ↓	MCQ	SAR	SA	LA	Total
NUMBER SYSTEMS	1 (1)	2 (1)	3 (1)	–	6 (3)
ALGEBRA Polynomials, Linear Equations in Two Variables	1 (1)	4 (2)	9 (3)	6 (1)	20 (7)
COORDINATE GEOMETRY	1 (1)	2 (1)	3 (1)	–	6 (3)
GEOMETRY Introduction to Euclid's Geometry, Lines and Angles, Triangles, Quadrilaterals, Areas, Circles, Constructions	4 (4)	–	6 (2)	12 (2)	22 (8)
MENSURATION Areas, Surface areas and Volumes	2 (2)	–	6 (2)	6 (1)	14 (5)
STATISTICS AND PROBABILITY Statistics, Probability	1 (1)	2 (1)	3 (1)	6 (1)	12 (4)
Total	10 (10)	10 (05)	30 (10)	30 (05)	80 (30)

SUMMARY

Multiple Choice Questions (MCQ)	Number of Questions: 10	Marks: 10
Short Answer with Reasoning (SAR)	Number of Questions: 05	Marks: 10
Short Answer (SA)	Number of Questions: 10	Marks: 30
Long Answer (LA)	Number of Questions: 05	Marks: 30
Total	30	80

MATHEMATICS
CLASS IX

Time: 3 hours

Maximum Marks: 80

General Instructions

1. All questions are compulsory.
2. The question paper consists of four sections A, B, C and D. Section A has 10 questions of 1 mark each, section B has 5 questions of 2 marks each, section C has 10 questions of 3 marks each and section D is of 5 questions of 6 marks each.
3. There is no overall choice. However internal choices are provided in 2 questions of 3 marks each and 1 question of 6 marks.
4. Construction should be drawn neatly and exactly as per the given measurements.
5. Use of calculators is not allowed.

SECTION A

In Questions 1 to 10, four options of answer are given in each, out of which only one is correct. Write the correct option.

1. Which of the following represent a line parallel to x -axis?
(A) $x + y = 3$ (B) $2x + 3 = 7$ (C) $2y - 3 = y + 1$ (D) $x + 3 = 0$
2. Zero of the polynomial $p(x) = 3x + 5$ is :
(A) 0 (B) -5 (C) $\frac{5}{3}$ (D) $\frac{-5}{3}$
3. The abscissa of a point P, in cartesian plane, is the perpendicular distance of P from:
(A) y -axis (B) x -axis (C) origin (D) line $y = x$
4. The reflex angle is an angle:
(A) less than 90° (B) greater than 90°
(C) less than 180° (D) greater than 180°
5. If the lines l , m , and n are such that $l \parallel m$ and $m \parallel n$, then
(A) $l \parallel n$ (B) $l \perp n$
(C) l and n are intersecting (D) $l = n$

6. In Fig.1, $\angle B < \angle A$ and $\angle D > \angle C$, then:
- (A) $AD > BC$
 (B) $AD = BC$
 (C) $AD < BC$
 (D) $AD = 2BC$

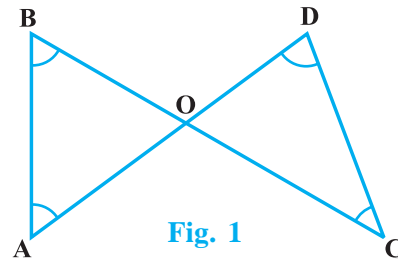

Fig. 1

7. In Fig. 2, the measure of $\angle BCD$ is:
- (A) 100°
 (B) 70°
 (C) 80°
 (D) 30°

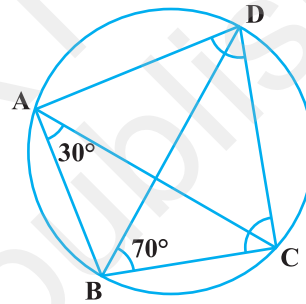

Fig. 2

8. The height of a cone of diameter 10 cm and slant height 13cm is:
- (A) $\sqrt{69}$ cm (B) 12 cm (C) 13 cm (D) $\sqrt{194}$ cm
9. The surface area of a solid hemisphere with radius r is
- (A) $4\pi r^2$ (B) $2\pi r^2$ (C) $3\pi r^2$ (D) $\frac{2}{3}\pi r^3$
10. If the mode of the following data 10, 11, 12, 10, 15, 14, 15, 13, 12, x, 9, 7 is 15, then the value of x is:
- (A) 10 (B) 15 (C) 12 (D) $\frac{21}{2}$

SECTION B

11. Find an irrational number between two numbers $\frac{1}{7}$ and $\frac{2}{7}$ and justify your answer.

It is given that $\frac{1}{7} = 0.\overline{142857}$

12. Without actually dividing, find the remainder when $x^4 + x^3 - 2x^2 + x + 1$ is divided by $x - 1$, and justify your answer.
13. Give the equations of two lines passing through $(2, 10)$. How many more such lines are there, and why?
14. Two points with coordinates $(2, 3)$ and $(2, -1)$ lie on a line, parallel to which axis? Justify your answer.
15. A die was rolled 100 times and the number of times, 6 came up was noted. If the experimental probability calculated from this information is $\frac{2}{5}$, then how many times 6 came up? Justify your answer.

SECTION C

16. Find three rational numbers between $\frac{2}{5}$ and $\frac{3}{5}$.
 17. Factorise: $54a^3 - 250b^3$
 18. Check whether the polynomial $p(y) = 2y^3 + y^2 + 4y - 15$ is a multiple of $(2y - 3)$.
 19. If the point $(3, 4)$ lies on the graph of the equation $2y = ax + 6$, find whether $(6, 5)$ also lies on the same graph.
 20. Plot $(-3, 0)$, $(5, 0)$ and $(0, 4)$ on cartesian plane. Name the figure formed by joining these points and find its area.
 21. Diagonals AC and BD of a trapezium ABCD with $AB \parallel DC$, intersect each other at O. Prove that $\text{ar}(\text{AOD}) = \text{ar}(\text{BOC})$.
- OR
- ABCD is a rectangle in which diagonal AC bisects $\angle A$ as well as $\angle C$. Show that ABCD is a square.
22. Construct a triangle PQR in which $\angle Q = 60^\circ$ and $\angle R = 45^\circ$ and $PQ + QR + PR = 11$ cm.

23. Find the area of a triangle two sides of which are 18 cm and 10 cm and the perimeter is 42 cm.
24. A cylindrical pillar is 50 cm in diameter and 3.5 m in height. Find the cost of painting the curved surface of the pillar at the rate of Rs 12.50 per m².

OR

The height of a solid cone is 16 cm and its base radius is 12 cm. Find the total surface area of cone. $\left(\text{Use } \pi = \frac{22}{7}\right)$

25. A die is thrown 400 times, the frequency of the outcomes of the events are given as under.

Outcome	1	2	3	4	5	6
Frequency	70	65	60	75	63	67

Find the probability of occurrence of an odd number.

SECTION D

26. A field is in the shape of a trapezium whose parallel sides are 25 m and 10 m. The non-parallel sides are 14 m and 13 m. Find the area of the field.
27. Draw a histogram and frequency polygon for the following distribution:

Marks Obtained	0 - 10	10 - 20	20 - 30	30 - 40	40 - 50	50 - 60	60 - 70	70 - 80
No. of Students	7	10	6	8	12	3	2	2

28. Prove that two triangles are congruent if two angles and the included side of one triangle are equal to two angles and the included side of the other triangle.

Using above, prove that CD bisects AB, in Figure 3, where AD and BC are equal perpendiculars to line segment AB.

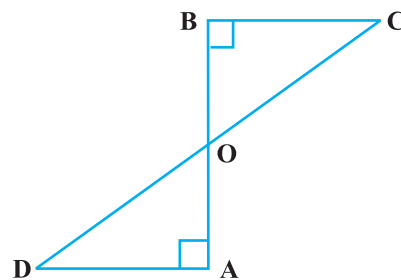

Fig. 3

29. Prove that equal chords AB and CD of a circle subtend equal angles at the centre.
Use the above to find $\angle ABO$ in Figure 4, where O is the centre of the circle

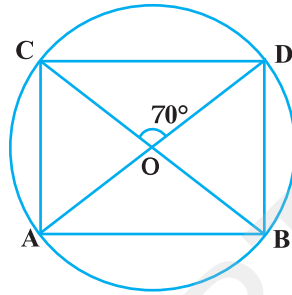

Fig. 4

30. Factorise the expression

$$8x^3 + 27y^3 + 36x^2y + 54xy^2$$

OR

The Linear equation that converts Fahrenheit to Celsius is $F = \left(\frac{9}{5}\right)C + 32$

Draw the graph of the equation using Celsius for x-axis and Fahrenheit for y-axis.
From the graph find the temperature in Fahrenheit for a temperature of 30°C.

Marking Scheme

MATHEMATICS – CLASSIX

SECTION A

1. (C) 2. (D) 3. (A) 4. (D) 5. (A)
 6. (C) 7. (C) 8. (B) 9. (C) 10. (B)
 (1 × 10 = 10)

SECTION B

11. Since $\frac{1}{7} = 0.142857\ 142857\ \dots$ and $\left(\frac{1}{2}\right)$

$\frac{2}{7} = 0.285714\ 285714\ \dots$ $\left(\frac{1}{2}\right)$

Therefore, an irrational number between $\frac{1}{7}$ and $\frac{2}{7}$ $\left(\frac{1}{2}\right)$

can be 0.1501500 15000 ... $\left(\frac{1}{2}\right)$

12. Let $p(x) = x^4 + x^3 - 2x^2 + x + 1$, then by Remainder theorem,

on dividing with $x - 1$, remainder is $f(1)$ $\left(1\ \frac{1}{2}\right)$

Therefore, remainder = $1 + 1 - 2 + 1 + 1 = 2$ $\left(\frac{1}{2}\right)$

13. $3x - y + 4 = 0$, $x - y + 8 = 0$ $\left(\frac{1}{2}\right)$

Through one point, infinitely many lines can pass.

Therefore, infinitely many such lines will be there. $\left(1\ \frac{1}{2}\right)$

14. Parallel to y -axis.

$\left(\frac{1}{2}\right)$

Since x -coordinate of both points is 2.

So, both points lie on the line $x = 2$ which is parallel to y -axis.

$\left(1\frac{1}{2}\right)$

15. Answer is 40

$\left(\frac{1}{2}\right)$

Probability of an event = $\frac{\text{frequency of the event occurring}}{\text{the total number of trials}}$

Therefore, $\frac{2}{5} = \frac{x}{100}$, i.e., $x = 40$

$\left(1\frac{1}{2}\right)$

SECTION C

16. $\frac{2}{5} = \frac{8}{20}$ and $\frac{3}{5} = \frac{12}{20}$

(1)

Therefore, three rational numbers can be $\frac{9}{20}, \frac{10}{20}, \frac{11}{20}$

(2)

17. $54a^3 - 250b^3 = 2[27a^3 - 125b^3]$

(1)

$= 2[(3a)^3 - (5b)^3]$

$\left(\frac{1}{2}\right)$

$= 2(3a - 5b)(9a^2 + 15ab + 25b^2)$

$\left(1\frac{1}{2}\right)$

18. $p(y)$ is a multiple of $(2y - 3)$ if $(2y - 3)$ is a factor of $p(y)$.

(1)

Therefore, $p\left(\frac{3}{2}\right)$ must be zero

$p\left(\frac{3}{2}\right) = 2\left(\frac{3}{2}\right)^3 + \left(\frac{3}{2}\right)^2 + 4\left(\frac{3}{2}\right) - 15$

(1)

$$= \frac{27}{4} + \frac{9}{4} + 6 - 15 = 9 + 6 - 15 = 0$$

Hence, $p(y)$ is a multiple of $(2y - 3)$ (1)

19. Since, $(3, 4)$ lies on $2y = ax + 6$. Therefore, $8 = 3a$, i.e., $a = \frac{2}{3}$ (1)

Now, we have $2y = \frac{2}{3}x + 6$ ($\frac{1}{2}$)

Putting $x = 6$, $y = 5$, we get $10 = \frac{2}{3} \cdot 6 + 6 = 4 + 6 = 10$ (1)

Hence $(6, 5)$ lies on the same graph ($\frac{1}{2}$)

20. Correct plotting figure formed is a triangle ($1\frac{1}{2}$)

Figure formed is a triangle

$$\text{Area} = \frac{1}{2} \times 8 \times 4 = 16 \text{ sq. unit}$$

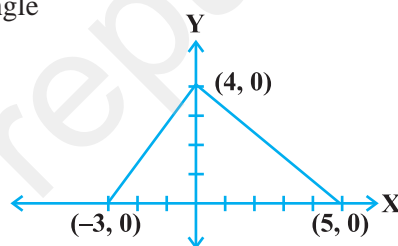

21. ar (ABD) = ar (ABC) (1)

[Δ s between same parallels and on the same base]

Therefore, ar (ABD) - ar (AOB) = ar (ABC) - ar (AOB) (1)

i.e., ar (AOD) = ar (BOC) (1)

OR

Given ABCD is a rectangle

with $\angle 1 = \angle 2$ and $\angle 3 = \angle 4$

But $\angle 1 = \angle 4$ (alternate angles)

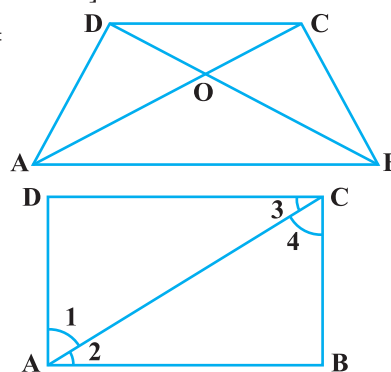

Therefore, we have $\angle 2 = \angle 4$, which means $AB = BC$, similarly $AD = CD$ ($\frac{1}{2}$)

Hence, ABCD is a square. (1)

22. For neat and accurate construction (3)

23. $a = 18$ cm, $b = 10$ cm. Therefore, $c = 42 - 28 = 14$ cm and $s = 21$ ($\frac{1}{2}$)

$$\Delta = \sqrt{s(s-a)(s-b)(s-c)} \quad \left(\frac{1}{2}\right)$$

$$= \sqrt{(21)(3)(11)(7)} \quad (1)$$

$$= 21\sqrt{11} \text{ or } 69.69 \text{ cm}^2 \text{ (Approx)} \quad (1)$$

24. $r = 25$ cm, $h = 3.5$ m ($\frac{1}{2}$)

$$\text{C.S.A.} = 2\pi rh$$

$$= 2 \times \frac{22}{7} \times \frac{25}{100} \times \frac{35}{10} = \frac{11}{2} \text{ m}^2 \quad \left(1 \frac{1}{2}\right)$$

$$\text{Therefore, cost} = \text{Rs } \frac{11}{2} \times 12.50 = \text{Rs } 68.75 \quad (1)$$

OR

$$h = 16 \text{ cm and } r = 12 \text{ cm, therefore, } l = \sqrt{h^2 + r^2} = 20 \text{ cm} \quad (1)$$

$$\text{Total surface area} = \pi rl + \pi r^2 = \pi r(l + r) \quad (1)$$

$$= \frac{22}{7} \times 12 \times 32 = 1206 \frac{6}{7} \text{ cm}^2 \quad (1)$$

25. Sum of frequencies = 400 ($\frac{1}{2}$)

Odd numbers are 1, 3, 5

$$\text{Therefore, frequency of all odd numbers} = 70 + 60 + 63 = 193 \quad (1)$$

$$P(\text{event}) = \frac{\text{Frequency of occurring of event}}{\text{The total number of trials}} \quad \left(\frac{1}{2}\right)$$

$$\text{Therefore, probability of occurrence of odd number} = \frac{193}{400} \quad (1)$$

SECTION D

26. Let $AL = x$, therefore, $BM = 15 - x$

$$\text{Now } 13^2 - x^2 = (14)^2 - (15 - x)^2$$

Solving to get $x = 6.6$ m

$$\begin{aligned} \text{Therefore, height } DL &= \sqrt{(13)^2 - (6.6)^2} \\ &= 11.2 \text{ m} \end{aligned}$$

$$\text{Therefore, area of trapezium} = \frac{1}{2} (\text{sum of parallel sides}) \times \text{height} \quad (1)$$

$$= \frac{1}{2} (10 + 25) (11.2) \text{ m}^2 \quad (1)$$

$$= 196 \text{ m}^2 \quad \left(\frac{1}{2}\right)$$

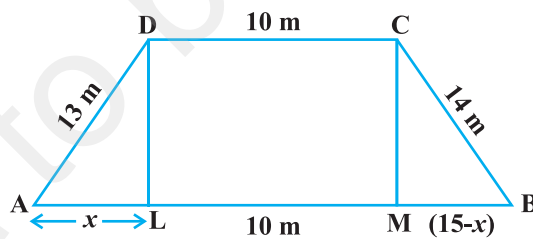

27. For correctly making the histogram (4)

For correctly making the frequency polygon (2)

28. For correct given, to prove, construction and figure

$$\left(\frac{1}{2} \times 4 = 2\right)$$

For correct proof

$$(2)$$

$$\angle A = \angle B = 90^\circ$$

$$\left(\frac{1}{2}\right)$$

$$\angle 1 = \angle 2 \quad (\text{vert. opp. angles})$$

$$AD = BC \quad (\text{Given})$$

$$\left(\frac{1}{2}\right)$$

Therefore, $\Delta AOD \cong \Delta BOC$ [AAS]

$$\left(\frac{1}{2}\right)$$

Therefore, $AO = OB$, i.e., CD bisects AB

$$\left(\frac{1}{2}\right)$$

29. For correct given, to prove, construction and figure

$$\left(\frac{1}{2} \times 4 = 2\right)$$

For correct proof

$$(2)$$

$$\angle AOB = \angle DOC = 70^\circ$$

$$(1)$$

$$\text{Therefore, } \angle ABO = 180^\circ - [70^\circ + 40^\circ] = 70^\circ$$

$$(1)$$

30. $8x^3 + 27y^3 + 36x^2y + 54xy^2$

$$= (2x)^3 + (3y)^3 + 18xy(2x + 3y)$$

$$(2)$$

$$= (2x)^3 + (3y)^3 + 3(2x)(3y)(2x + 3y)$$

$$(2)$$

$$= (2x + 3y)^3 = (2x + 3y)(2x + 3y)(2x + 3y)$$

$$(2)$$

OR

For correct graph taking Celsius on x -axis and Fahrenheit on y -axis

$$(4)$$

From graph getting $F = 86$ for $C = 30$

$$(2)$$

NOTES

© NCERT
not to be republished

NOTES

© NCERT
not to be republished

Other Exemplar Problems by NCERT

- Exemplar Problems in Science for Class IX
- Exemplar Problems in Physics for Class XI
- Exemplar Problems in Chemistry for Class XI
- Exemplar Problems in Mathematics for Class XI
- Exemplar Problems in Biology for Class XI

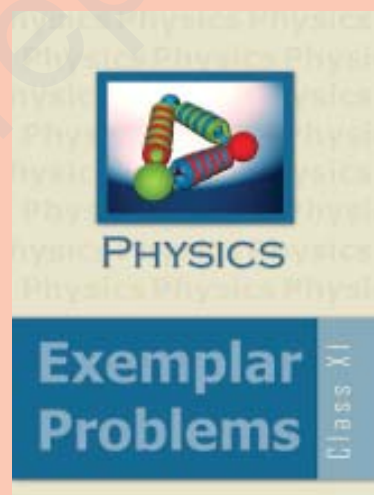
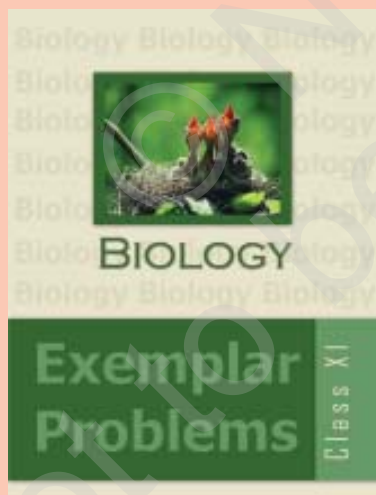

ANSWERS

EXERCISE 1.1

- | | | | | |
|---------|---------|---------|---------|---------|
| 1. (C) | 2. (C) | 3. (D) | 4. (D) | 5. (D) |
| 6. (C) | 7. (D) | 8. (C) | 9. (C) | 10. (C) |
| 11. (B) | 12. (A) | 13. (D) | 14. (B) | 15. (B) |
| 16. (C) | 17. (C) | 18. (B) | 19. (A) | 20. (A) |
| 21. (C) | | | | |

EXERCISE 1.2

- Yes. Let $x = 21$, $y = \sqrt{2}$ be a rational number.
Now $x + y = 21 + \sqrt{2} = 21 + 1.4142 \dots = 22.4142 \dots$
Which is non-terminating and non-recurring. Hence $x + y$ is irrational.
- No. $0 \times \sqrt{2} = 0$ which is not irrational.
- False. Although $\frac{\sqrt{2}}{3}$ is of the form $\frac{p}{q}$ but here p , i.e., $\sqrt{2}$ is not an integer.
 - False. Between 2 and 3, there is no integer.
 - False, because between any two rational numbers we can find infinitely many rational numbers.
 - True. $\frac{\sqrt{2}}{\sqrt{3}}$ is of the form $\frac{p}{q}$ but p and q here are not integers.
 - False, as $(\sqrt[4]{2})^2 = \sqrt{2}$ which is not a rational number.

(vi) False, because $\frac{\sqrt{12}}{\sqrt{3}} = \sqrt{4} = 2$ which is a rational number.

(vii) False, because $\frac{\sqrt{15}}{\sqrt{3}} = \sqrt{5} = \frac{\sqrt{5}}{1}$ which is p , i.e., $\sqrt{5}$ is not an integer.

4. (i) Rational, as $\sqrt{196} = 14$

(ii) $3\sqrt{18} = 9\sqrt{2}$, which is the product of a rational and an irrational number and so an irrational number.

(iii) $\sqrt{\frac{9}{27}} = \frac{1}{\sqrt{3}}$, which is the quotient of a rational and an irrational number and so an irrational number.

(iv) $\frac{\sqrt{28}}{\sqrt{343}} = \frac{2}{7}$, which is a rational number.

(v) Irrational, $-\sqrt{0.4} = -\frac{2}{\sqrt{10}}$, which is the quotient of a rational and an irrational.

(vi) $\frac{\sqrt{12}}{\sqrt{75}} = \frac{2}{7}$, which is a rational number.

(vii) Rational, as decimal expansion is terminating.

(viii) $(1 + \sqrt{5}) - (4 + \sqrt{5}) = -3$, which is a rational number.

(ix) Rational, as decimal expansion is non-terminating recurring.

(x) Irrational, as decimal expansion is non-terminating non-recurring.

EXERCISE 1.3

1. Rational numbers: (ii), (iii)

Irrational numbers: (i), (iv)

2. (i) $-1.1, -1.2, -1.3$

(ii) $0.101, 0.102, 0.103$

(iii) $\frac{51}{70}, \frac{52}{70}, \frac{53}{70}$

(iv) $\frac{9}{40}, \frac{17}{80}, \frac{19}{80}$

3. (i) 2.1, 2.040040004 ... (ii) 0.03, 0.007000700007, ...
 (iii) $\frac{5}{12}$, 0.414114111 ... (iv) 0, 0.151151115 ...
 (v) 0.151, 0.151551555 ... (vi) 1.5, 1.585585558 ...
 (vii) 3, 3.101101110 ... (viii) 0.00011, .0001131331333 ...
 (ix) 1, 1.909009000 ... (x) 6.3753, 6.375414114111 ...
7. (i) $\frac{1}{5}$ (ii) $\frac{8}{9}$ (iii) $\frac{47}{9}$ (iv) $\frac{1}{999}$ (v) $\frac{23}{90}$
 (vi) $\frac{133}{990}$ (vii) $\frac{8}{2475}$ (viii) $\frac{40}{99}$
9. (i) $\sqrt{5}$ (ii) $\frac{7\sqrt{6}}{12}$ (iii) $168\sqrt{2}$ (iv) $\frac{8}{3}$ (v) $\frac{34\sqrt{3}}{3}$
 (vi) $5 - 2\sqrt{6}$ (vii) 0 (viii) $\frac{5}{4}\sqrt{2}$ (ix) $\frac{\sqrt{3}}{2}$
10. (i) $\frac{2}{9}\sqrt{3}$ (ii) $\frac{2}{3}\sqrt{30}$ (iii) $\frac{2+3\sqrt{2}}{8}$ (iv) $\sqrt{41} + 5$
 (v) $7 + 4\sqrt{3}$ (vi) $3\sqrt{2} - 2\sqrt{3}$ (vii) $5 + 2\sqrt{6}$ (viii) $9 + 2\sqrt{15}$
 (ix) $\frac{9 + 4\sqrt{6}}{15}$
11. (i) $a = 11$ (ii) $a = \frac{9}{11}$ (iii) $b = \frac{-5}{6}$ (iv) $a = 0, b = 1$
12. $2\sqrt{3}$
13. (i) 2.309 (ii) 2.449 (iii) 0.463 (iv) 0.414 (v) 0.318
14. (i) 6 (ii) $\frac{2025}{64}$ (iii) 9 (iv) 5
 (v) $3^{-\frac{1}{3}}$ (vi) -3 (vii) 16

EXERCISE 1.4

1. $\frac{167}{90}$ 2. 1 3. 2.063 4. 7
 5. 98 6. $\frac{1}{2}$ 7. 214

EXERCISE 2.1

1. (C) 2. (B) 3. (A) 4. (D) 5. (B)
 6. (A) 7. (D) 8. (C) 9. (B) 10. (B)
 11. (D) 12. (C) 13. (B) 14. (D) 15. (D)
 16. (B) 17. (D) 18. (D) 19. (C) 20. (C)
 21. (C)

EXERCISE 2.2

1. Polynomials: (i), (ii), (iv), (vii)
 because the exponent of the variable after simplification in each of these is a whole number.
2. (i) False, because a binomial has exactly two terms.
 (ii) False, $x^3 + x + 1$ is a polynomial but not a binomial.
 (iii) True, because a binomial is a polynomial whose degree is a whole number ≥ 1 , so, degree can be 5 also.
 (iv) False, because zero of a polynomial can be any real number.
 (v) False, a polynomial can have any number of zeroes. It depends upon the degree of the polynomial.
 (vi) False, $x^5 + 1$ and $-x^5 + 2x + 3$ are two polynomials of degree 5 but the degree of the sum of the two polynomials is 1.

EXERCISE 2.3

1. (i) One variable (ii) One variable
 (iii) Three variable (iv) Two variables
2. (i) 1 (ii) 0 (iii) 5 (iv) 7

3. (i) 6 (ii) $\frac{1}{5}$ (iii) -1 (iv) $\frac{1}{5}$
4. (i) 1 (ii) 0 (iii) 3 (iv) -16
5. Constant Polynomial : (v)
 Linear Polynomials : (iii), (vi), (x)
 Quadratic Polynomials : (iv), (viii), (ix)
 Cubic Polynomials : (i), (ii), (vii)
6. (i) $10x$ (ii) $x^{20} + 1$ (iii) $2x^2 - x - 1$
7. 61, -143 8. $\frac{-31}{4}$
9. (i) -3, 3, -39 (ii) -4, -3, 0
10. (i) False (ii) True (iii) False (iv) True (v) True
11. (i) 4 (ii) $\frac{1}{2}$ (iii) $\frac{7}{2}$ (iv) 0
12. 0 13. $x^3 + x^2 + x + 1, 2$
14. (i) 0 (ii) 62 (iii) $\frac{3}{2}$ (iv) $\frac{-136}{27}$
15. (i) No (ii) No 17. (i) 19. 1
20. $\frac{3}{2}$ 21. -2 22. 2
23. (i) $(x + 6)(x + 3)$ (ii) $(3x - 1)(2x + 3)$
 (iii) $(x - 5)(2x + 3)$ (iv) $2(7 + r)(6 - r)$
24. (i) $(x - 2)(x + 3)(2x - 5)$ (ii) $(x - 1)(x - 2)(x - 3)$
 (iii) $(x + 1)(x - 2)(x + 2)$ (iv) $(x - 1)(x + 1)(3x - 1)$
25. (i) 1092727 (ii) 10302 (iii) 998001
26. (i) $(2x + 5)^2$ (ii) $(3y - 11z)^2$ (iii) $\left(3x - \frac{1}{6}\right)\left(x + \frac{5}{6}\right)$
27. (i) $3(x - 1)(3x - 1)$ (ii) $(3x - 2)(3x - 2)$

28. (i) $16a^2 + b^2 + 4c^2 - 8ab - 4bc + 16ac$
 (ii) $9a^2 + 25b^2 + c^2 - 30ab + 10bc - 6ac$
 (iii) $x^2 + 4y^2 + 9z^2 - 4xy - 12yz + 6xz$
29. (i) $(3x + 2y - 4z)(3x + 2y - 4z)$ (ii) $(-5x + 4y + 2z)(-5x + 4y + 2z)$
 (iii) $(4x - 2y + 3z)(4x - 2y + 3z)$
30. 29
31. (i) $27a^3 - 54a^2b + 36ab^2 - 8b^3$ (ii) $\frac{1}{x^3} + \frac{y}{x^2} + \frac{y^2}{3x} + \frac{y^3}{27}$
 (iii) $64 - \frac{16}{x} + \frac{4}{3x^2} - \frac{1}{27x^3}$
32. (i) $(1 - 4a)(1 - 4a)(1 - 4a)$ (ii) $\left(2p + \frac{1}{5}\right)\left(2p + \frac{1}{5}\right)\left(2p + \frac{1}{5}\right)$
33. (i) $\frac{x^3}{8} + 8y^3$ (ii) $x^6 - 1$
34. (i) $(1 + 4x)(1 - 4x + 16x^2)$ (ii) $(a - \sqrt{2}b)(a^2 + \sqrt{2}ab + 2b^2)$
35. $8x^3 - y^3 + 27z^3 + 18xyz$
36. (i) $(a - 2b - 4c)(a^2 + 4b^2 + 16c^2 + 2ab - 8bc + 4ac)$
 (ii) $(\sqrt{2}a + 2b - 3c)(2a^2 + 4b^2 + 9c^2 - 2\sqrt{2}ab + 6bc + 3\sqrt{2}ac)$
37. (i) $-\frac{5}{12}$ (ii) -0.018 38. $3(x - 2y)(2y - 3z)(3z - x)$
39. (i) 0 (ii) 0
40. One possible answer is:
 Length = $2a - 1$, Breadth = $2a + 3$

EXERCISE 2.4

1. -1 2. $a = 5$; 62 5. $-120x^2y - 250y^3$ 6. $x^3 - 8y^3 - z^3 - 6xyz$

EXERCISE 3.1

- | | | | | |
|---------|---------|---------|---------|---------|
| 1. (B) | 2. (C) | 3. (C) | 4. (A) | 5. (D) |
| 6. (A) | 7. (C) | 8. (C) | 9. (D) | 10. (C) |
| 11. (C) | 12. (D) | 13. (B) | 14. (B) | 15. (B) |
| 16. (D) | 17. (B) | 18. (D) | 19. (B) | 20. (C) |
| 21. (B) | 22. (C) | 23. (C) | 24. (A) | |

EXERCISE 3.2

1. (i) False, because if ordinate of a point is zero, the point lies on the x -axis.
- (ii) False $(1, -1)$, lies in IV quadrant and $(-1, 1)$ lies in II quadrant.
- (iii) False, because in the coordinates of a point abscissa comes first and then the ordinate .
- (iv) False, because a point on the y -axis is of the form $(0, y)$.
- (v) True, because in the II quadrant, signs of abscissa and ordinate are $-$, $+$, respectively.

EXERCISE 3.3

1. $P(1, 1)$, $Q(-3, 0)$, $R(-3, -2)$, $S(2, 1)$, $T(4, -2)$, $O(0, 0)$
2. Trapezium
4. (i) Collinear (ii) Not collinear (iii) Collinear
5. (i) II (ii) III (iii) II (iv) I
6. (i) $P(3, 2)$, $R(3, 0)$, $Q(3, -1)$ (ii) 0
7. II, IV, x -axis, I, III
8. C, D, E, G 10. $(7, 0)$, $(0, -7)$ 11. (i) $(0, 0)$ (ii) $(0, -4)$ (iii) $(5, 0)$

EXERCISE 3.4

1. $C(-2, -4)$ 2. $(0, 0)$, $(-5, 0)$, $(0, -3)$ 3. $(4, 3)$
4. (i) A, L and O
(ii) G I and O
(iii) D and H
5. (i) $(2, 1)$, (ii) $(5, 7)$

EXERCISE 4.1

- | | | | | |
|---------|---------|---------|---------|---------|
| 1. (C) | 2. (A) | 3. (A) | 4. (A) | 5. (D) |
| 6. (B) | 7. (C) | 8. (A) | 9. (B) | 10. (A) |
| 11. (C) | 12. (B) | 13. (A) | 14. (C) | 15. (C) |
| 16. (B) | 17. (C) | 18. (C) | 19. (D) | |

EXERCISE 4.2

- True, since $(0, 3)$ satisfies the equation $3x + 4y = 12$.
- False, since $(0, 7)$ does not satisfy the equation.
- True, since $(-1, 1)$ and $(-3, 3)$ satisfy the given equation and two points determine a unique line.
- True, since this graph is a line parallel to y -axis at a distance 3 units (to the right) from it.
- False, since the point $(3, -5)$ does not satisfy the given equation.
- False, since every point on the graph of the equation represents a solution.
- False, since the graph of a linear equation in two variables is always a line.

EXERCISE 4.3

- Graph of each equation is a line passing through $(0, 0)$.
- $(2, 3)$
- Any line parallel to x -axis and at a distance of 3 units below it is given by $y = -3$
- $x + y = 10$
- $y = 3x$
- $\frac{5}{3}$
- (i) one (ii) Infinitely many solutions
- (i) $(4, 0)$ (ii) $(0, 2)$
- $c = \frac{8-2x}{x}, x \neq 0$
- $y = 3x; y = 15.$

EXERCISE 4.4

- The graph cuts the x -axis at $(3, 0)$ and the y -axis at $(0, 2)$.
- The graph cuts the x -axis at $(2, 0)$ and the y -axis at $\left(0, \frac{3}{2}\right)$.

4. (i) 30°C (ii) 95°F (iii) $32^{\circ}\text{F}, \left(\frac{-160}{9}\right)^{\circ}\text{C}$
 (iv) -40
5. (i) 104°F (ii) 343°K
6. $y = mx$, where y denotes the force, x denotes the acceleration and m denotes the constant mass.
 (i) 30 Newton (ii) 36 Newton

EXERCISE 5.1

- | | | | | |
|---------|---------|---------|---------|---------|
| 1. (A) | 2. (C) | 3. (B) | 4. (A) | 5. (A) |
| 6. (A) | 7. (A) | 8. (B) | 9. (B) | 10. (D) |
| 11. (A) | 12. (B) | 13. (A) | 14. (C) | 15. (B) |
| 16. (A) | 17. (C) | 18. (C) | 19. (A) | 20. (A) |
| 21. (C) | 22. (B) | | | |

EXERCISE 5.2

- False, it is valid only for the figures in the plane.
- False, boundaries of the solids are surfaces.
- False, the edges of surfaces are line.
- True, one of the Euclid's axioms.
- True, because of one of Euclid's axioms.
- False, statements that are proved are theorms.
- True, it is an equivalent version of Euclid's fifth postulate.
- True, it is an equivalent version of Euclid's fifth postulate.
- True, these geometries are different from Euclidean geometry.

EXERCISE 5.4

- Answer this question on the same manner as given in the solution of Sample Question 1 in (E).
- No 4. No 5. Consistent

EXERCISE 6.1

1. (C) 2. (D) 3. (A) 4. (A) 5. (D)
6. (A) 7. (C) 8. (B)

EXERCISE 6.2

- $x + y$ must be equal to 180° . For ABC to be a line, the sum of the two adjacent angles must be 180° .
- No, angle sum will be less than 180° .
- No, angle sum cannot be more than 180° .
- None, angle sum cannot be 181° .
- Infinitely many triangles. sum of the angles of every triangle is 180° .
- 136° .
- No, each of these will be a right angle only when they form a linear pair.
- Each will be a right angle. Linear pair axiom .
- $l \parallel m$ because $132^\circ + 48^\circ = 180^\circ$, p is not parallel to q , because $73^\circ + 106^\circ \neq 180^\circ$.
- No, they are parallel

EXERCISE 6.3

7. 90° 8. $40^\circ, 60, 80^\circ$

EXERCISE 7.1

1. (C) 2. (B) 3. (B) 4. (C) 5. (A)
6. (B) 7. (B) 8. (D) 9. (B) 10. (A)
11. (B)

EXERCISE 7.2

- QR; They will be congruent by ASA.
- RP; They will be congruent by AAS.
- No; Angles must be included angles.
- No; Sides must be corresponding sides.

5. No; Sum of the two sides = the third side.
6. No; $BC = PQ$.
7. Yes; They are corresponding sides.
8. PR; Side opposite the greater angle is longer.
9. Yes; $AB + BD > AD$ and $AC + CD > AD$.
10. Yes; $AB + BM > AM$ and $AC + CM > AM$.
11. No; Sum of two sides is less than the third side.
12. Yes, because in each case the sum of two sides is greater than the third side.

EXERCISE 7.4

1. $60^\circ, 60^\circ, 60^\circ$
3. It is defective to use $\angle ABD = \angle ACD$ for proving this result.
19. $\angle B$ will be greater.

EXERCISE 8.1

- | | | | | |
|---------|---------|---------|---------|---------|
| 1. (D) | 2. (B) | 3. (C) | 4. (C) | 5. (D) |
| 6. (C) | 7. (D) | 8. (C) | 9. (B) | 10. (D) |
| 11. (C) | 12. (C) | 13. (C) | 14. (C) | |

EXERCISE 8.2

1. 6 cm, 4 cm; Diagonals of a parallelogram bisect each other.
2. No; Diagonals of a parallelogram bisect each other.
3. No; Angle sum must be 360° .
4. Trapezium.
5. Rectangle.
6. No; Diagonals of a rectangle need not be perpendicular.
7. No; sum of the angles of a quadrilateral is 360° .
8. 3.5 cm, as $DE = \frac{1}{2} AC$.
9. Yes; because $BD = EF$ and $CD = EF$.
10. 55° , $\angle F = \angle A$ and $\angle A = \angle C$.
11. No; Angle sum of a quadrilateral is 360° .

12. Yes, Angle sum of a quadrilateral is 360° .

13. 145°

14. 4 cm

EXERCISE 8.3

1. 84°

2. 135° each

3. $120^\circ, 60^\circ, 120^\circ, 60^\circ$

4. $120^\circ, 60^\circ, 120^\circ, 60^\circ$

EXERCISE 8.4

2. 4 cm.

EXERCISE 9.1

1. (A)

2. (D)

3. (D)

4. (C)

5. (C)

6. (A)

7. (B)

8. (D)

9. (B)

10. (B)

EXERCISE 9.2

1. False, since $\text{ar}(AXCD) = \text{ar}(ABCD) - \text{ar}(BCX) = 48 - 12 = 36 \text{ cm}^2$

2. True, $SR = \sqrt{(13)^2 - (5)^2} = 12$, $\text{ar}(PAS) = \frac{1}{2} \text{ar}(PQRS) = 30 \text{ cm}$

3. False, because area of $\Delta QSR = 90 \text{ cm}^2$ and area of $\Delta ASR <$ area of ΔQRS .

4. True, $\frac{\text{ar BDE}}{\text{ar ABC}} = \frac{\frac{\sqrt{3} (BD)^2}{4}}{\frac{\sqrt{3} (BC)^2}{4}} = \frac{(BD)^2}{(BC)^2} = \frac{1}{4}$

5. False, because $\text{ar}(DPC) = \frac{1}{2} \text{ar}(ABCD) = \text{ar}(EFGD)$

EXERCISE 9.3

3. (i) 90 cm^2 (ii) 45 cm^2 (iii) 45 cm^2

7. 12 cm^2

EXERCISE 10.1

1. (D)

2. (A)

3. (C)

4. (B)

5. (D)

6. (A)

7. (C)

8. (B)

9. (C)

10. (D)

EXERCISE 10.2

1. True. Because the distances from the centre of two chords are equal.
2. False. The angles will be equal only if $AB = AC$.
3. True. Because equal chords of congruent circles subtend equal angles at the respective centres.
4. False. Because a circle through two points cannot pass through a point which is collinear to these two points.
5. True. Because AB will be the diameter.
6. True. As $\angle C$ is right angle, $AC^2 + BC^2 = AB^2$.
7. False, as $\angle A + \angle C = 90^\circ + 95^\circ = 185^\circ \neq 180^\circ$.
8. False, because there can be many points D such that $\angle BDC = 60^\circ$ and each such point cannot be the centre of the circle through A,B,C.
9. True. Angles in the same segment.
10. True. $\angle B = 180^\circ - 120^\circ = 60^\circ$, $\angle CAB = 90^\circ - 60^\circ = 30^\circ$.

EXERCISE 10.3

1. 1:1
9. 60°
14. 30°
15. 100°
16. 50°
17. 40°
19. 278
20. $\angle BOC = 66^\circ$, $\angle AOC = 54^\circ$

EXERCISE 10.4

13. $x = 30^\circ$, $y = 15^\circ$
14. 30°

EXERCISE 11.1

1. (B)
2. (A)
3. (D)

EXERCISE 11.2

1. True. As $52.5^\circ = \frac{210^\circ}{4}$ and $210^\circ = 180^\circ + 30^\circ$ which can be constructed.
2. False. As $42.5^\circ = \frac{1}{2} \times 85^\circ$ and 85° cannot be constructed.
3. False. As $BC + AC$ must be greater than AB which is not so.
4. True. As $AC - AB < BC$, i.e., $AC < AB + BC$.

5. False. As $\angle B + \angle C = 105^\circ + 90^\circ = 195^\circ > 180^\circ$.
 6. True. As $\angle B + \angle C = 60^\circ + 45^\circ = 105^\circ < 180^\circ$.

EXERCISE 11.3

2. Yes.

EXERCISE 12.1

1. (A) 2. (D) 3. (C) 4. (A) 5. (D)
 6. (B) 7. (C) 8. (A) 9. (B)

EXERCISE 12.2

1. False, area of the triangle is 12 cm^2 .
 2. True, area of the triangle = $\frac{1}{2} \times 4 \times 4 = 8 \text{ cm}^2$
 3. True, Each of equal side = 3 cm.
 4. False, area of the triangle $16\sqrt{3} \text{ cm}^2$.
 5. True, the other diagonal will be 12 cm.
 6. False, the area of the parallelogram is 35 cm^2 .
 7. False, area is the sum of all the six equilateral triangles.
 8. True, area = 306 m^2 .
 9. True, area of the triangle = $12\sqrt{105} \text{ cm}^2$.

EXERCISE 12.3

1. Rs 10500 2. Rs 84,000 3. $300\sqrt{3} \text{ cm}$ 4. $32\sqrt{2} \text{ cm}^2$
 5. 180 cm^2 6. $600\sqrt{15} \text{ m}^2$ 7. $2100\sqrt{15} \text{ m}^2$ 8. $24(\sqrt{6} + 1) \text{ cm}^2$
 9. Rs 960 10. 114 m^2

EXERCISE 12.4

1. Yellow : 484 m²; Red : 242 m²; Green : 373.04 m²
2. $20\sqrt{30}$ cm²
3. 23 cm, 27 cm
4. 374 cm²
5. Rs 19200
6. 3 cm
7. 45 cm, 40 cm
8. 1632 cm², 1868 cm²

EXERCISE 13.1

1. (D)
2. (C)
3. (B)
4. (C)
5. (B)
6. (B)
7. (A)
8. (B)
9. (A)
10. (A)

EXERCISE 13.2

1. True, $\frac{4}{3}\pi r^3 = \frac{2}{3}\pi r^2(2r)$
2. False, since new volume = $\frac{1}{3}\pi\left(\frac{r}{2}\right)^2 \cdot 2h = \frac{1}{2}$ (Original volume)
3. True, since $r^2 + h^2 = l^2$
4. True, $2\pi rh = 2\pi(2r) \cdot \frac{h}{2}$
5. True, since volume of cone = $\frac{1}{3}\pi r^2 \cdot (2r) = \frac{2}{3}\pi r^3 =$ volume of hemisphere
6. True, since $V_1 =$ volume of cylinder = $\pi r^2 h$
 since $V_2 =$ volume of cone = $\frac{1}{3}\pi r^2 h$ Therefore, $V_1 = 3V_2$
7. True, $V_1 = \frac{1}{3}\pi r^2 r$, $V_2 = \frac{2}{3}\pi r^3$, $V_3 = \pi r^2 r$
8. False, $\sqrt{3}a = 6\sqrt{3} = a = 6$ Therefore, edge = 6 cm

9. True, V_1 (volume of cube) = a^3

$$\text{Radius of sphere} = \frac{a}{2}. V_2 \text{ (Volume of sphere)} = \frac{4}{3}\pi \frac{a^3}{8}$$

$$V_1 : V_2 = 6 : \pi$$

10. True, new volume = $\pi(2r)^2 \cdot \left(\frac{h}{2}\right) = 2[\pi r^2 h]$. Therefore, volume is doubled.

EXERCISE 13.3

1. 488 cm³ 2. 7.5 cm³ 3. 14.8 cm³ 4. 471.42 m²
 5. 5 cm 6. 739.2 litres 7. 200 revolutions 8. 40 days
 9. 8 laddoos 10. 304 cm³, 188.5 cm²

EXERCISE 13.4

1. 8800 cm³ 2. 677.6 cm³ 3. 110, 241.7 cm³ 4. 668.66 m³
 5. 16 : 9 6. 30.48 cm³ 7. 50% 8. (i) 9152 cm²
 (ii) 55440 cm³

EXERCISE 14.1

1. (B) 2. (D) 3. (B) 4. (C) 5. (B)
 6. (B) 7. (B) 8. (C) 9. (B) 10. (D)
 11. (D) 12. (C) 13. (B) 14. (D) 15. (B)
 16. (B) 17. (C) 18. (B) 19. (D) 20. (B)
 21. (C) 22. (C) 23. (C) 24. (B) 25. (D)
 26. (C) 27. (C) 28. (C) 29. (C) 30. (D)

EXERCISE 14.2

1. Not correct. The classes are of varying widths, not of uniform widths.
 2. Median will be a good representative of the data, because
 (i) each value occurs once,
 (ii) The data is influenced by extreme values.

3. Data has to be arranged in ascending (or descending) order before finding the median.
4. No, the data have first to be arranged in ascending (or descending) order before finding the median.
5. It is not correct. In a histogram, the area of each rectangle is propotional to the frequency of its class.
6. It is not correct. Reason is that differnce between two consecutive marks should be equal to the class size.
7. No. Infact the number of children who watch TV for 10 or more hours a week is $4 + 2$, i.e., 6.
8. No, since the number of trials in which the event can happen cannot be negative, and the total number of trials is always positive.
9. No, since the number of trials in which the event can happen cannot be greater than the total number of trials.
10. No. As the number of tosses of a coin increases, the ratio of the number of heads to the total number of tosses will be **nearer** to $\frac{1}{2}$, not exactly $\frac{1}{2}$.

EXERCISE 14.3

1.

Blood Group	Number of Students (frequency)
A	12
B	8
AB	4
O	6
Total	30

2.

Digit	0	1	2	3	4	5	6	7	8	9
Frequency	1	2	5	6	3	4	3	2	5	4

3. Scores	48	58	64	66	69	71	73	81	83	84
Frequency	3	3	4	7	6	3	2	1	2	2

4. Class	0 - 10	10 - 20	20 - 30	30 - 40	40 - 50
Frequency	4	8	13	12	6

Class size = 10

5. Class intervals	Frequency
149.5 - 153.5	7
153.5 - 157.5	7
157.5 - 161.5	15
161.5 - 165.5	10
165.5 - 169.5	5
169.5 - 173.5	6

153.5 is included in the class interval 153.5-157.5 and 157.5 in 157.5 - 161.5.

9. 20 **10.** 8.05 **11.** 72.2 **12.** 80.94 **13.** 20

14. Median = 12, mode = 10

15. Class intervals	Frequency
150 - 200	50
200 - 250	30
250 - 300	35
300 - 350	20
350 - 400	10
Total	145

16. (i) 0.06 (ii) 0.19 (iii) $\frac{3}{400}$

17. (i) 0.06 (ii) 0.086 (iii) 0.282 (iv) 0.254

18. (i) $\frac{4}{7}$ (ii) $\frac{59}{350}$ (iii) $\frac{669}{700}$

19. (i) 0.25 (ii) 0.75 (iii) 0.73 (iv) 0

20. (i) 0.675 (ii) 0.325 (iii) 0.135 (iv) 0.66

EXERCISE 14.4

1.

Class	0 - 9	10 - 19	20 - 29	30 - 39	40 - 49	50 - 59	60 - 69	70 - 79	80 - 89	90 - 99
Frequency	1	2	5	6	3	4	3	2	5	4

2.

Class intervals	Frequency
0 - 10	4
10 - 20	7
20 - 30	5
30 - 40	10
40 - 50	5
50 - 60	8
60 - 70	5
70 - 80	8
80 - 90	5
90 - 100	3

10. $a = 5$, frequency of 30 is 28 and that of 70 is 24.

11. 2 : 1

12. Mean = 75.64, Median = 77, Mode = 85