

PHYSICS

Exemplar Problems

CLASS
XI

PHYSICS
Exemplar Problems

Class XI



राष्ट्रीय शैक्षिक अनुसंधान और प्रशिक्षण परिषद्
NATIONAL COUNCIL OF EDUCATIONAL RESEARCH AND TRAINING

© NCERT
not to be republished

FOREWORD

The National Curriculum Framework (NCF) – 2005 initiated a new phase of development of syllabi and textbooks for all stages of school education. Conscious effort has been made to discourage rote learning and to diffuse sharp boundaries between different subject areas. This is well in tune with the NPE-1986 and *Learning Without Burden – 1993* that recommend child-centred system of education. The textbooks for classes IX and XI were released in 2006 and for classes X and XII in 2007. Overall, the books have been well received by students and teachers.

NCF-2005 notes that treating the prescribed textbooks as the sole basis of examination is one of the key reasons why other resources and sites of learning are ignored. It further reiterates that the methods used for teaching and evaluation will also determine how effective these textbooks prove for making children's life at school a happy experience, rather than source of stress or boredom. It calls for reform in examination system currently prevailing in the country.

The position papers of the National Focus Groups on *Teaching of Science*, *Teaching of Mathematics* and *Examination Reform* envisage that the Physics question papers, set in annual examinations conducted by the various Boards do not really assess genuine understanding of the subjects. The quality of question papers is often not up to the mark. They usually seek mere information based on rote memorisation, and fail to test higher-order skills like reasoning and analysis, let alone lateral thinking, creativity and judgment. Good unconventional questions, challenging problems and experiment-based problems rarely find a place in question papers. In order to address the issue, and also to provide additional learning material, the Department of Education in Science and Mathematics (DESM) has made an attempt to develop resource book of exemplar problems in different subjects at secondary and higher secondary stages. Each resource book contains different types of questions of varying difficulty level. Some questions would require the students to apply simultaneous understanding of more than one chapters/units. These problems are *not* meant to serve merely as question bank for examinations but are primarily meant to improve the quality of teaching/learning process in schools. It is expected that these problems would encourage teachers to design quality questions on their own. Students and teachers should always keep in mind that

examination and assessment should test comprehension, information recall, analytical thinking and problem- solving ability, creativity and speculative ability.

A team of experts and teachers with an understanding of the subject and a proper role of examination worked hard to accomplish this task. The material was discussed, edited, and finally included in this resource book.

NCERT would welcome suggestions from students, teachers and parents which would help us to further improve the quality of material in subsequent editions.



YASH PAL

Chairperson

National Steering Committee
National Council of Educational
Research and Training

New Delhi
21 May 2008

PREFACE

The Department of Education in Science and Mathematics (DESM), National Council of Educational Research and Training (NCERT), initiated the development of 'Exemplar Problems' in science and mathematics for secondary and higher secondary stages after completing the preparation of textbooks based on National Curriculum Framework - 2005.

The main objective of the book on 'Exemplar Problems in Physics' is to provide the teachers and students a large number of quality problems with varying cognitive levels to facilitate teaching-learning of concepts in physics that are presented through the textbook for Class XI. It is envisaged that the problems included in this volume would help the teachers to design tasks to assess effectiveness of their teaching and to know about the achievement of their students besides facilitating preparation of balanced question papers for unit and terminal tests. The feedback based on the analysis of students' responses may help the teachers in further improving the quality of classroom instructions. In addition, the problems given in this book are also expected to help the teachers to perceive the basic characteristics of good quality questions and motivate them to frame similar questions on their own. Students can benefit themselves by attempting the exercises given in the book for self assessment and also in mastering the basic techniques of problem solving. Some of the questions given in the book are expected to challenge the understanding of the concepts of physics of the students and their ability to apply them in novel situations.

The problems included in this book were prepared through a series of workshops organised by the DESM for their development and refinement involving practicing teachers, subject experts from universities and institutes of higher learning, and the members of the physics group of the DESM whose names appear separately. We gratefully acknowledge their efforts and thank them for their valuable contribution in our endeavour to provide good quality instructional material for the school system.

I express my gratitude to Professor Krishna Kumar, *Director* and Professor G.Ravindra, *Joint Director*, NCERT for their valuable motivation and guidance from time to time. Special thanks are also due to Dr. V.P.Srivastava, *Reader* in Physics, DESM for coordinating the programme, taking pains in editing and refinement of problems and for making the manuscript pressworthy.

We look forward to feedback from students, teachers and parents for further improvement of the contents of this book.

HUKUM SINGH
Professor and Head
DESM, NCERT
New Delhi

DEVELOPMENT TEAM

MEMBER

A.W. Joshi, *Professor (Retired)*, Department of Physics, University of Pune, Pune.

Atul Mody, *Lecturer(SG)*, Department of Physics, VES College of Arts, Science & Commerce, Chembur, Mumbai.

B.K.Sharma, *Professor of Physics*, Department of Education in Science & Mathematics, NCERT, New Delhi.

B.Labroo, *PGT, Physics*, Convent of Jesus & Mary, New Delhi.

Gagan Gupta, *Reader in Physics*, Department of Education in Science & Mathematics, NCERT, New Delhi

H.S.Mani, *Raja Ramanna Fellow*, Institute of Mathematical Sciences, Chennai.

Kiran Nayak, *PGT, Physics*, Apeejay School, Pitampura, New Delhi.

K.Thyagarajan, *Professor*, Department of Physics, I.I.T., Delhi.

M.A.H.Ahsan, *Lecturer*, Department of Physics, Jamia Millia Islamia, New Delhi.

Pragya Nopany, *PGT, Physics*, Birla Vidya Niketan, Pushpa Vihar, New Delhi.

Pushpa Tyagi, *PGT, Physics*, Sanskriti School, Chanakya Puri, New Delhi.

Ravi Bhattacharjee, *Reader in Physics*, SGTB Khalsa College, University of Delhi, Delhi.

R.S.Dass, *Vice-Principal (Retired)*, Balwant Ray Mehta Sr.Sec. School, Lajpat Nagar, New Delhi.

R.Joshi, *Lecturer (SG) in Physics*, Department of Education in Science & Mathematics, NCERT, New Delhi.

S.Rai Choudhury, *Raja Ramanna Fellow*, Centre for Theoretical Physics, Jamia Millia Islamia, New Delhi.

S.D.Joglekar, *Professor*, Department of Physics, I.I.T., Kanpur.

Shashi Prabha, *Lecturer in Physics*, Department of Education in Science & Mathematics, NCERT, New Delhi.

MEMBER – COORDINATOR

V.P.Srivastava, *Reader*, Department of Education in Science & Mathematics, NCERT, New Delhi.

ACKNOWLEDGEMENT

The National Council of Educational Research and Training acknowledges the valuable contribution of the individuals and organisations involved in the development of Exemplar Problems in Physics for Class XI. The Council also acknowledges the valuable contribution of the following academics for reviewing and refining the manuscripts of this book: Aprajita, *PGT(Physics)*, Kendriya Vidyalaya No.3, Delhi Cantt., Naraina, New Delhi; Anu Venugopalan, *Reader in Physics*, School of Basic and Applied Sciences, GGSIP University, New Delhi; C.Kadolkar, *Associate Professor*, Department of Physics, I.I.T., Guwahati; Girija Shankar, *PGT(Physics)*, Rajkiya Pratibha Vikas Vidyalaya, Surajmal Vihar, Delhi; Mahesh Shetti, *Lecturer in Physics*, Wilson College, Mumbai; R.P.Sharma, *Education Officer (Science)*, CBSE, New Delhi; Sangeeta Gadre, *Reader in Physics*, Kirori Mal College, University of Delhi, Delhi; Sucharita Basu Kasturi, *PGT(Physics)*, Sardar Patel Vidyalaya, Lodi Estate, New Delhi; Shyama Rath, *Reader*, Department of Physics, University of Delhi, Delhi and Yashu Kumar, *PGT(Physics)*, Kulachi Hans Raj Model School, Ashok Vihar, New Delhi.

Special thanks are due to Hukum Singh, *Professor and Head*, DESM, NCERT for his support. The Council also acknowledges the efforts of Deepak Kapoor, *Incharge*, Computer Station; Ritu Jha, *DTP Operators*.

The contributions of the Publication Department in bringing out this book are also duly acknowledged.

CONTENTS

FOREWORD	iii
PREFACE	v
CHAPTER ONE	
INTRODUCTION	1
CHAPTER TWO	
UNITS AND MEASUREMENTS	5
CHAPTER THREE	
MOTION IN A STRAIGHT LINE	13
CHAPTER FOUR	
MOTION IN A PLANE	19
CHAPTER FIVE	
LAWS OF MOTION	29
CHAPTER SIX	
WORK, ENERGY AND POWER	38
CHAPTER SEVEN	
SYSTEM OF PARTICLES AND ROTATIONAL MOTION	50
CHAPTER EIGHT	
GRAVITATION	57
CHAPTER NINE	
MECHANICAL PROPERTIES OF SOLIDS	65
CHAPTER TEN	
MECHANICAL PROPERTIES OF FLUIDS	72

CHAPTER ELEVEN THERMAL PROPERTIES OF MATTER	77
CHAPTER TWELVE THERMODYNAMICS	83
CHAPTER THIRTEEN KINETIC THEORY	90
CHAPTER FOURTEEN OSCILLATIONS	97
CHAPTER FIFTEEN WAVES	105
ANSWERS	113
SAMPLE QUESTION PAPERS	181

Chapter One

INTRODUCTION

The National Curriculum Framework (NCF) – 2005 initiated a new phase of curriculum revision. First, new syllabi for Science and Mathematics for all stages of school education were developed. Based on these syllabi, new textbooks were developed. As a part of this effort, Physics textbooks for Classes XI and XII were published in 2006 and 2007, respectively.

One of the major concerns expressed in NCF-2005 is regarding *Examination Reform*.

According to NCF-2005, “A good evaluation and examination system can become an integral part of the learning process and benefit both the learners themselves and the educational system by giving credible feedback”.

It further notes that,

“Education is concerned with preparing citizens for a meaningful and productive life, and evaluation should be a way of providing credible feedback on the extent to which we have been successful in imparting such an education. Seen from this perspective, current processes of evaluation, which measure and assess a very limited range of faculties, are highly inadequate and do not provide a complete picture of an individual’s ability or progress towards fulfilling the aims of education”.

The purpose of assessment is to determine the extent to which learning has taken, on the one hand and to improve the teaching-learning process and instructional materials, on the other. It should inter alia be able to review the objectives that have been identified for different school stages by gauging the extent to which the capabilities of learners have been developed. Tests should be so designed that we must be able to gauge what children have learnt, and their ability to use this knowledge for problem-solving and application in the real world. In addition, they must also be able to test the processes of thinking to gauge if the learner has also learnt where to find information, how to use new information, and to analyse and evaluate the same. The types of questions that are set for assessment need to go beyond what is given in the book. Often children's learning is restricted as teachers do not accept their answers if they are different from what is presented in the guidebooks. Designing good test items and questions is an art, and teachers should spend time thinking about and devising such questions.

Observing on the current practices of the different boards of school education in the country, the National Focus Group paper on *Examination Reform* says:

“...Because the quality of question papers is low, they usually call for rote memorisation and fail to test higher-order skills like reasoning and analysis, let alone lateral thinking, creativity and judgement”.

It further advocates the inclusion of Multiple Choice Questions (MCQ)- a type of question that has great untapped potential. It also notes the limitation of testing through MCQ's only. “While MCQ can more deeply probe the level of conceptual understanding of students and gauge a student's mastery of subtleties, it cannot be the only kind of question in any examination. MCQs work best in conjunction with some open-ended essay questions in the second part of the paper, which tests expression and the ability to formulate an argument using relevant facts.”

In order to address to the problem, the Department of Education in Science and Mathematics undertook a programme, *Development of Exemplar Problems in Physics* for Class XI during 2007-08. Problems based on different chapters in textbook of Physics for Class XI published by the NCERT has been developed. Problems have been classified broadly into five categories:

1. Multiple Choice Questions I (MCQ I): only one correct answer.
2. Multiple Choice Questions II (MCQII): may have one or more than one correct answer.
3. Very Short Answer Questions (VSA): may be answered in one/two sentences.
4. Short Answer Questions (SA): require some analytical/numerical work.
5. Long Answer Questions (LA): require detailed analytical/numerical solution.

Though most of the questions given in a particular chapter are based on concepts covered in that chapter, some questions have been developed which are based on concepts covered in more than one chapter.

One of the major objectives of involving learners in solving problems in teaching-learning process is to promote a more active learning environment, improve student learning and also support young teachers in their professional development during their early formative teaching experiences. For this to be achieved, problem-solving based on good question should form an integral part of teaching-learning process. Good questions engage students in progressively deeper levels of thinking and reasoning. It is envisaged that the questions presented through this book would motivate teachers to design good questions. What makes a question good? According to Robyn L. Miller et al.¹

Some characteristics of a good question are:

- stimulates students' interest and curiosity.
- helps students monitor their understanding.
- offers students frequent opportunities to make conjectures and argue about their validity.
- draws on students' prior knowledge, understanding, and/or misunderstanding.
- provides teachers a tool for frequent formative assessments of what their students are learning.
- supports teachers' efforts to foster an active learning environment.

A NOTE TO STUDENTS

A good number of problems have been provided in this book. Some are easy, some are of average difficult level, some difficult and some problems will challenge even the best amongst you. It is advised that you first master the concepts covered in your textbook, solve the examples and exercises provided in your textbook and then attempt to solve the problems given in this book. There is no single prescription which can help you in solving each and every problem in physics but still researches in physics education show that most of the problems can be attempted if you follow certain steps in a sequence. The following prescription due to Dan Styer² presents one such set of steps :

1. Strategy design
 - (a) Classify the problem by its method of solution.
 - (b) Summarise the situation with a diagram.
 - (c) Keep the goal in sight (perhaps by writing it down).
2. Execution tactics
 - (a) Work with symbols.
 - (b) Keep packets of related variables together.

¹ http://www.math.cornell.edu/~maria/mathfest_education_preprint.pdf

² <http://www.oberlin.edu/physics/dstyer/SolvingProblems.html>

- (c) Be neat and organised.
 - (d) Keep it simple.
3. Answer checking
- (a) Dimensionally consistent?
 - (b) Numerically reasonable (including sign)?
 - (c) Algebraically possible? (Example: no imaginary or infinite answers)
 - (d) Functionally reasonable? (Example: greater range with greater initial speed)
 - (e) Check special cases and symmetry.
 - (f) Report numbers with units specified and with reasonable significant figures.

We would like to emphasise that the problems in this book should be used to improve the quality of teaching-learning process of physics. Some can be directly adopted for evaluation purpose but most of them should be suitably adapted according to the time/marks assigned. Most of the problems included under SA and LA can be used to generate more problems of VSA or SA categories, respectively.

Chapter Two

UNITS AND MEASUREMENTS



MCQ I

- 2.1** The number of significant figures in 0.06900 is
- (a) 5
 - (b) 4
 - (c) 2
 - (d) 3
- 2.2** The sum of the numbers 436.32, 227.2 and 0.301 in appropriate significant figures is
- (a) 663.821
 - (b) 664
 - (c) 663.8
 - (d) 663.82
- 2.3** The mass and volume of a body are 4.237 g and 2.5 cm³, respectively. The density of the material of the body in correct significant figures is

- (a) 1.6048 g cm^{-3}
 (b) 1.69 g cm^{-3}
 (c) 1.7 g cm^{-3}
 (d) 1.695 g cm^{-3}
- 2.4** The numbers 2.745 and 2.735 on rounding off to 3 significant figures will give
 (a) 2.75 and 2.74
 (b) 2.74 and 2.73
 (c) 2.75 and 2.73
 (d) 2.74 and 2.74
- 2.5** The length and breadth of a rectangular sheet are 16.2 cm and 10.1cm, respectively. The area of the sheet in appropriate significant figures and error is
 (a) $164 \pm 3 \text{ cm}^2$
 (b) $163.62 \pm 2.6 \text{ cm}^2$
 (c) $163.6 \pm 2.6 \text{ cm}^2$
 (d) $163.62 \pm 3 \text{ cm}^2$
- 2.6** Which of the following pairs of physical quantities does not have same dimensional formula?
 (a) Work and torque.
 (b) Angular momentum and Planck's constant.
 (c) Tension and surface tension.
 (d) Impulse and linear momentum.
- 2.7** Measure of two quantities along with the precision of respective measuring instrument is
 $A = 2.5 \text{ m s}^{-1} \pm 0.5 \text{ m s}^{-1}$
 $B = 0.10 \text{ s} \pm 0.01 \text{ s}$
 The value of $A B$ will be
 (a) $(0.25 \pm 0.08) \text{ m}$
 (b) $(0.25 \pm 0.5) \text{ m}$
 (c) $(0.25 \pm 0.05) \text{ m}$
 (d) $(0.25 \pm 0.135) \text{ m}$
- 2.8** You measure two quantities as $A = 1.0 \text{ m} \pm 0.2 \text{ m}$, $B = 2.0 \text{ m} \pm 0.2 \text{ m}$. We should report correct value for \sqrt{AB} as:
 (a) $1.4 \text{ m} \pm 0.4 \text{ m}$
 (b) $1.41\text{m} \pm 0.15 \text{ m}$
 (c) $1.4\text{m} \pm 0.3 \text{ m}$
 (d) $1.4\text{m} \pm 0.2 \text{ m}$

- 2.9** Which of the following measurements is most precise?
- 5.00 mm
 - 5.00 cm
 - 5.00 m
 - 5.00 km.
- 2.10** The mean length of an object is 5 cm. Which of the following measurements is most accurate?
- 4.9 cm
 - 4.805 cm
 - 5.25 cm
 - 5.4 cm
- 2.11** Young's modulus of steel is $1.9 \times 10^{11} \text{ N/m}^2$. When expressed in CGS units of dynes/cm², it will be equal to ($1\text{N} = 10^5 \text{ dyne}$, $1\text{m}^2 = 10^4 \text{ cm}^2$)
- 1.9×10^{10}
 - 1.9×10^{11}
 - 1.9×10^{12}
 - 1.9×10^{13}
- 2.12** If momentum (P), area (A) and time (T) are taken to be fundamental quantities, then energy has the dimensional formula
- $(P^1 A^{-1} T^1)$
 - $(P^2 A^1 T^1)$
 - $(P^1 A^{-1/2} T^1)$
 - $(P^1 A^{1/2} T^{-1})$

MCQ II

- 2.13** On the basis of dimensions, decide which of the following relations for the displacement of a particle undergoing simple harmonic motion is *not* correct:
- $y = a \sin 2\pi t / T$
 - $y = a \sin vt.$
 - $y = \frac{a}{T} \sin\left(\frac{t}{a}\right)$
 - $y = a\sqrt{2} \left(\sin \frac{2\pi t}{T} - \cos \frac{2\pi t}{T} \right)$
- 2.14** If P, Q, R are physical quantities, having different dimensions, which of the following combinations can never be a meaningful quantity?
- $(P - Q)/R$
 - $PQ - R$

- (c) PQ/R
 (d) $(PR - Q^2)/R$
 (e) $(R + Q)/P$
- 2.15** Photon is quantum of radiation with energy $E = h\nu$ where ν is frequency and h is Planck's constant. The dimensions of h are the same as that of
- (a) Linear impulse
 (b) Angular impulse
 (c) Linear momentum
 (d) Angular momentum
- 2.16** If Planck's constant (h) and speed of light in vacuum (c) are taken as two fundamental quantities, which one of the following can, in addition, be taken to express length, mass and time in terms of the three chosen fundamental quantities?
- (a) Mass of electron (m_e)
 (b) Universal gravitational constant (G)
 (c) Charge of electron (e)
 (d) Mass of proton (m_p)
- 2.17** Which of the following ratios express pressure?
- (a) Force/ Area
 (b) Energy/ Volume
 (c) Energy/ Area
 (d) Force/ Volume
- 2.18** Which of the following are *not* a unit of time?
- (a) Second
 (b) Parsec
 (c) Year
 (d) Light year

VSA

- 2.19** Why do we have different units for the same physical quantity?
- 2.20** The radius of atom is of the order of 1 \AA and radius of nucleus is of the order of fermi. How many magnitudes higher is the volume of atom as compared to the volume of nucleus?
- 2.21** Name the device used for measuring the mass of atoms and molecules.

2.22 Express unified atomic mass unit in kg.

2.23 A function $f(\theta)$ is defined as:

$$f(\theta) = 1 - \theta + \frac{\theta^2}{2!} - \frac{\theta^3}{3!} + \frac{\theta^4}{4!} \dots$$

Why is it necessary for q to be a dimensionless quantity?

2.24 Why length, mass and time are chosen as base quantities in mechanics?

SA

- 2.25** (a) The earth-moon distance is about 60 earth radius. What will be the diameter of the earth (approximately in degrees) as seen from the moon?
(b) Moon is seen to be of $(\frac{1}{2})^\circ$ diameter from the earth. What must be the relative size compared to the earth?
(c) From parallax measurement, the sun is found to be at a distance of about 400 times the earth-moon distance. Estimate the ratio of sun-earth diameters.

2.26 Which of the following time measuring devices is most precise?

- (a) A wall clock.
(b) A stop watch.
(c) A digital watch.
(d) An atomic clock.

Give reason for your answer.

2.27 The distance of a galaxy is of the order of 10^{25} m. Calculate the order of magnitude of time taken by light to reach us from the galaxy.

2.28 The vernier scale of a travelling microscope has 50 divisions which coincide with 49 main scale divisions. If each main scale division is 0.5 mm, calculate the minimum inaccuracy in the measurement of distance.

2.29 During a total solar eclipse the moon almost entirely covers the sphere of the sun. Write the relation between the distances and sizes of the sun and moon.

2.30 If the unit of force is 100 N, unit of length is 10 m and unit of time is 100 s, what is the unit of mass in this system of units?

- 2.31** Give an example of
- a physical quantity which has a unit but no dimensions.
 - a physical quantity which has neither unit nor dimensions.
 - a constant which has a unit.
 - a constant which has no unit.
- 2.32** Calculate the length of the arc of a circle of radius 31.0 cm which subtends an angle of $\frac{\pi}{6}$ at the centre.
- 2.33** Calculate the solid angle subtended by the periphery of an area of 1 cm^2 at a point situated symmetrically at a distance of 5 cm from the area.
- 2.34** The displacement of a progressive wave is represented by $y = A \sin(\omega t - kx)$, where x is distance and t is time. Write the dimensional formula of (i) ω and (ii) k .
- 2.35** Time for 20 oscillations of a pendulum is measured as $t_1 = 39.6 \text{ s}$; $t_2 = 39.9 \text{ s}$; $t_3 = 39.5 \text{ s}$. What is the precision in the measurements? What is the accuracy of the measurement?

LA

- 2.36** A new system of units is proposed in which unit of mass is $\alpha \text{ kg}$, unit of length $\beta \text{ m}$ and unit of time $\gamma \text{ s}$. How much will 5 J measure in this new system?
- 2.37** The volume of a liquid flowing out per second of a pipe of length l and radius r is written by a student as

$$v = \frac{\pi Pr^4}{8 \eta l}$$

where P is the pressure difference between the two ends of the pipe and η is coefficient of viscosity of the liquid having dimensional formula $\text{ML}^{-1}\text{T}^{-1}$.

Check whether the equation is dimensionally correct.

- 2.38** A physical quantity X is related to four measurable quantities a , b , c and d as follows:

$$X = a^2 b^3 c^{5/2} d^{-2}.$$

The percentage error in the measurement of a , b , c and d are 1%, 2%, 3% and 4%, respectively. What is the percentage error in

quantity X ? If the value of X calculated on the basis of the above relation is 2.763, to what value should you round off the result.

- 2.39** In the expression $P = E l^2 m^{-5} G^{-2}$, E , m , l and G denote energy, mass, angular momentum and gravitational constant, respectively. Show that P is a dimensionless quantity.
- 2.40** If velocity of light c , Planck's constant h and gravitational constant G are taken as fundamental quantities then express mass, length and time in terms of dimensions of these quantities.
- 2.41** An artificial satellite is revolving around a planet of mass M and radius R , in a circular orbit of radius r . From Kepler's Third law about the period of a satellite around a common central body, square of the period of revolution T is proportional to the cube of the radius of the orbit r . Show using dimensional analysis, that

$$T = \frac{k}{R} \sqrt{\frac{r^3}{g}},$$

where k is a dimensionless constant and g is acceleration due to gravity.

- 2.42** In an experiment to estimate the size of a molecule of oleic acid 1 mL of oleic acid is dissolved in 19 mL of alcohol. Then 1 mL of this solution is diluted to 20 mL by adding alcohol. Now 1 drop of this diluted solution is placed on water in a shallow trough. The solution spreads over the surface of water forming one molecule thick layer. Now, lycopodium powder is sprinkled evenly over the film and its diameter is measured. Knowing the volume of the drop and area of the film we can calculate the thickness of the film which will give us the size of oleic acid molecule.

Read the passage carefully and answer the following questions:

- Why do we dissolve oleic acid in alcohol?
 - What is the role of lycopodium powder?
 - What would be the volume of oleic acid in each mL of solution prepared?
 - How will you calculate the volume of n drops of this solution of oleic acid?
 - What will be the volume of oleic acid in one drop of this solution?
- 2.43**
- How many astronomical units (A.U.) make 1 parsec?
 - Consider a sunlike star at a distance of 2 parsecs. When it is seen through a telescope with 100 magnification, what should be the angular size of the star? Sun appears to be $(1/2)^\circ$ from

the earth. Due to atmospheric fluctuations, eye can't resolve objects smaller than 1 arc minute.

- (c) Mars has approximately half of the earth's diameter. When it is closest to the earth it is at about $1/2$ A.U. from the earth. Calculate what size it will appear when seen through the same telescope.

(*Comment* : This is to illustrate why a telescope can magnify planets but not stars.)

2.44 Einstein's mass - energy relation emerging out of his famous theory of relativity relates mass (m) to energy (E) as $E = mc^2$, where c is speed of light in vacuum. At the nuclear level, the magnitudes of energy are very small. The energy at nuclear level is usually measured in MeV, where $1 \text{ MeV} = 1.6 \times 10^{-13} \text{ J}$; the masses are measured in unified atomic mass unit (u) where $1u = 1.67 \times 10^{-27} \text{ kg}$.

- (a) Show that the energy equivalent of $1 u$ is 931.5 MeV .
(b) A student writes the relation as $1 u = 931.5 \text{ MeV}$. The teacher points out that the relation is dimensionally incorrect. Write the correct relation.

Chapter Three

MOTION IN A STRAIGHT LINE

MCQ I

- 3.1** Among the four graphs (Fig. 3.1), there is only one graph for which average velocity over the time interval $(0, T)$ can vanish for a suitably chosen T . Which one is it?

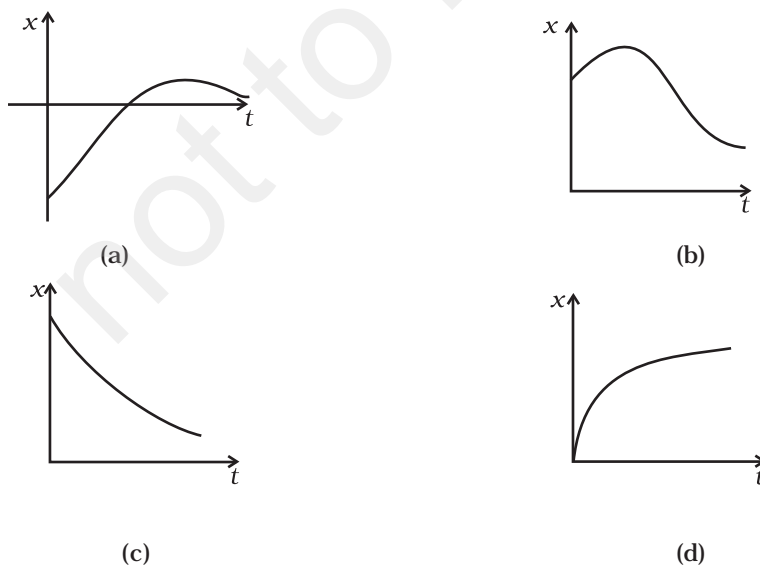

Fig. 3.1

3.2 A lift is coming from 8th floor and is just about to reach 4th floor. Taking ground floor as origin and positive direction upwards for all quantities, which one of the following is correct?

- (a) $x < 0, v < 0, a > 0$
- (b) $x > 0, v < 0, a < 0$
- (c) $x > 0, v < 0, a > 0$
- (d) $x > 0, v > 0, a < 0$

3.3 In one dimensional motion, instantaneous speed v satisfies $0 \leq v < v_0$.

- (a) The displacement in time T must always take non-negative values.
- (b) The displacement x in time T satisfies $-v_0 T < x < v_0 T$.
- (c) The acceleration is always a non-negative number.
- (d) The motion has no turning points.

3.4 A vehicle travels half the distance L with speed V_1 and the other half with speed V_2 , then its average speed is

- (a) $\frac{V_1 + V_2}{2}$
- (b) $\frac{2V_1 + V_2}{V_1 + V_2}$
- (c) $\frac{2V_1V_2}{V_1 + V_2}$
- (d) $\frac{L(V_1 + V_2)}{V_1V_2}$

3.5 The displacement of a particle is given by $x = (t - 2)^2$ where x is in metres and t in seconds. The distance covered by the particle in first 4 seconds is

- (a) 4 m
- (b) 8 m
- (c) 12 m
- (d) 16 m

3.6 At a metro station, a girl walks up a stationary escalator in time t_1 . If she remains stationary on the escalator, then the escalator take

her up in time t_2 . The time taken by her to walk up on the moving escalator will be

- (a) $(t_1 + t_2)/2$
- (b) $t_1 t_2 / (t_2 - t_1)$
- (c) $t_1 t_2 / (t_2 + t_1)$
- (d) $t_1 - t_2$

MCQ II

3.7 The variation of quantity A with quantity B, plotted in Fig. 3.2 describes the motion of a particle in a straight line.

- (a) Quantity B may represent time.
- (b) Quantity A is velocity if motion is uniform.
- (c) Quantity A is displacement if motion is uniform.
- (d) Quantity A is velocity if motion is uniformly accelerated.

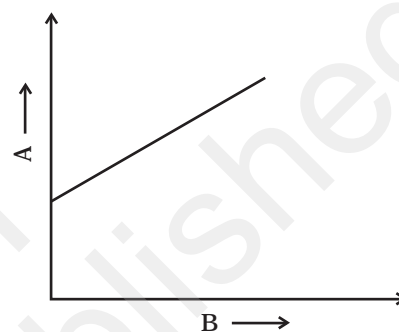

Fig. 3.2

3.8 A graph of x versus t is shown in Fig. 3.3. Choose correct alternatives from below.

- (a) The particle was released from rest at $t = 0$.
- (b) At B, the acceleration $a > 0$.
- (c) At C, the velocity and the acceleration vanish.
- (d) Average velocity for the motion between A and D is positive.
- (e) The speed at D exceeds that at E.

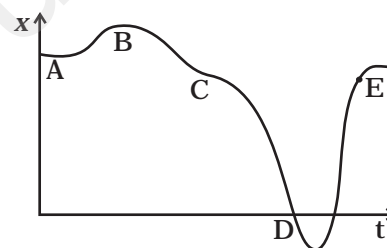

Fig. 3.3

3.9 For the one-dimensional motion, described by $x = t - \sin t$

- (a) $x(t) > 0$ for all $t > 0$.
- (b) $v(t) > 0$ for all $t > 0$.
- (c) $a(t) > 0$ for all $t > 0$.
- (d) $v(t)$ lies between 0 and 2.

3.10 A spring with one end attached to a mass and the other to a rigid support is stretched and released.

- (a) Magnitude of acceleration, when just released is maximum.
- (b) Magnitude of acceleration, when at equilibrium position, is maximum.
- (c) Speed is maximum when mass is at equilibrium position.
- (d) Magnitude of displacement is always maximum whenever speed is minimum.

- 3.11** A ball is bouncing elastically with a speed 1 m/s between walls of a railway compartment of size 10 m in a direction perpendicular to walls. The train is moving at a constant velocity of 10 m/s parallel to the direction of motion of the ball. As seen from the ground,
- the direction of motion of the ball changes every 10 seconds.
 - speed of ball changes every 10 seconds.
 - average speed of ball over any 20 second interval is fixed.
 - the acceleration of ball is the same as from the train.

VSA

- 3.12** Refer to the graphs in Fig 3.1. Match the following.

Graph	Characteristic
(a)	(i) has $v > 0$ and $a < 0$ throughout.
(b)	(ii) has $x > 0$ throughout and has a point with $v = 0$ and a point with $a = 0$.
(c)	(iii) has a point with zero displacement for $t > 0$.
(d)	(iv) has $v < 0$ and $a > 0$.

- 3.13** A uniformly moving cricket ball is turned back by hitting it with a bat for a very short time interval. Show the variation of its acceleration with time. (Take acceleration in the backward direction as positive).

- 3.14** Give examples of a one-dimensional motion where

- the particle moving along positive x -direction comes to rest periodically and moves *forward*.
- the particle moving along positive x -direction comes to rest periodically and moves *backward*.

- 3.15** Give example of a motion where $x > 0$, $v < 0$, $a > 0$ at a particular instant.

- 3.16** An object falling through a fluid is observed to have acceleration given by $a = g - bv$ where $g =$ gravitational acceleration and b is constant. After a long time of release, it is observed to fall with constant speed. What must be the value of constant speed?

SA

3.17 A ball is dropped and its displacement vs time graph is as shown Fig. 3.4 (displacement x is from ground and all quantities are +ve upwards).

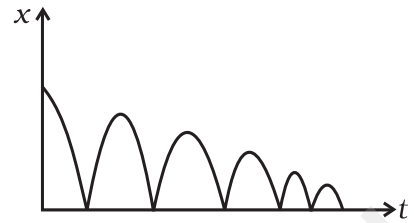

Fig. 3.4

- (a) Plot qualitatively velocity vs time graph.
- (b) Plot qualitatively acceleration vs time graph.

3.18 A particle executes the motion described by $x(t) = x_0(1 - e^{-\gamma t})$; $t \geq 0$, $x_0 > 0$.

- (a) Where does the particle start and with what velocity?
- (b) Find maximum and minimum values of $x(t)$, $v(t)$, $a(t)$. Show that $x(t)$ and $a(t)$ increase with time and $v(t)$ decreases with time.

3.19 A bird is tossing (flying to and fro) between two cars moving towards each other on a straight road. One car has a speed of 18 m/h while the other has the speed of 27km/h. The bird starts moving from first car towards the other and is moving with the speed of 36km/h and when the two cars were separated by 36 km. What is the total distance covered by the bird? What is the total displacement of the bird?

3.20 A man runs across the roof-top of a tall building and jumps horizontally with the hope of landing on the roof of the next building which is of a lower height than the first. If his speed is 9 m/s, the (horizontal) distance between the two buildings is 10 m and the height difference is 9 m, will he be able to land on the next building? (take $g = 10 \text{ m/s}^2$)

3.21 A ball is dropped from a building of height 45 m. Simultaneously another ball is thrown up with a speed 40 m/s. Calculate the relative speed of the balls as a function of time.

3.22 The velocity-displacement graph of a particle is shown in Fig. 3.5.

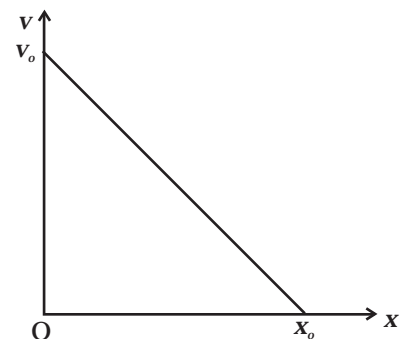

Fig. 3.5

- (a) Write the relation between v and x .
- (b) Obtain the relation between acceleration and displacement and plot it.

LA

3.23 It is a common observation that rain clouds can be at about a kilometre altitude above the ground.

- If a rain drop falls from such a height freely under gravity, what will be its speed? Also calculate in km/h. ($g = 10\text{m/s}^2$)
- A typical rain drop is about 4mm diameter. Momentum is mass \times speed in magnitude. Estimate its momentum when it hits ground.
- Estimate the time required to flatten the drop.
- Rate of change of momentum is force. Estimate how much force such a drop would exert on you.
- Estimate the order of magnitude force on umbrella. Typical lateral separation between two rain drops is 5 cm.
(Assume that umbrella is circular and has a diameter of 1m and cloth is not pierced through !!)

3.24 A motor car moving at a speed of 72km/h can not come to a stop in less than 3.0 s while for a truck this time interval is 5.0 s. On a highway the car is behind the truck both moving at 72km/h. The truck gives a signal that it is going to stop at emergency. At what distance the car should be from the truck so that it does not bump onto (collide with) the truck. Human response time is 0.5s.

(Comment : This is to illustrate why vehicles carry the message on the rear side. "Keep safe Distance")

3.25 A monkey climbs up a slippery pole for 3 seconds and subsequently slips for 3 seconds. Its velocity at time t is given by $v(t) = 2t(3-t)$; $0 < t < 3$ and $v(t) = -(t-3)(6-t)$ for $3 < t < 6$ s in m/s. It repeats this cycle till it reaches the height of 20 m.

- At what time is its velocity maximum?
- At what time is its average velocity maximum?
- At what time is its acceleration maximum in magnitude?
- How many cycles (counting fractions) are required to reach the top?

3.26 A man is standing on top of a building 100 m high. He throws two balls vertically, one at $t = 0$ and other after a time interval (less than 2 seconds). The later ball is thrown at a velocity of half the first. The vertical gap between first and second ball is +15 m at $t = 2$ s. The gap is found to remain constant. Calculate the velocity with which the balls were thrown and the exact time interval between their throw.

Chapter Four

MOTION IN A PLANE



MCQ I

4.1 The angle between $\mathbf{A} = \hat{i} + \hat{j}$ and $\mathbf{B} = \hat{i} - \hat{j}$ is

- (a) 45° (b) 90° (c) -45° (d) 180°

4.2 Which one of the following statements is true?

- (a) A scalar quantity is the one that is conserved in a process.
(b) A scalar quantity is the one that can never take negative values.
(c) A scalar quantity is the one that does not vary from one point to another in space.
(d) A scalar quantity has the same value for observers with different orientations of the axes.

4.3 Figure 4.1 shows the orientation of two vectors \mathbf{u} and \mathbf{v} in the XY plane.

If $\mathbf{u} = a\hat{i} + b\hat{j}$ and

$\mathbf{v} = p\hat{i} + q\hat{j}$

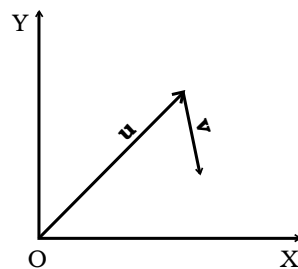

Fig. 4.1

which of the following is correct?

- (a) a and p are positive while b and q are negative.
- (b) a, p and b are positive while q is negative.
- (c) a, q and b are positive while p is negative.
- (d) a, b, p and q are all positive.

4.4 The component of a vector \mathbf{r} along X-axis will have maximum value if

- (a) \mathbf{r} is along positive Y-axis
- (b) \mathbf{r} is along positive X-axis
- (c) \mathbf{r} makes an angle of 45° with the X-axis
- (d) \mathbf{r} is along negative Y-axis

4.5 The horizontal range of a projectile fired at an angle of 15° is 50 m. If it is fired with the same speed at an angle of 45° , its range will be

- (a) 60 m
- (b) 71 m
- (c) 100 m
- (d) 141 m

4.6 Consider the quantities, pressure, power, energy, impulse, gravitational potential, electrical charge, temperature, area. Out of these, the only vector quantities are

- (a) Impulse, pressure and area
- (b) Impulse and area
- (c) Area and gravitational potential
- (d) Impulse and pressure

4.7 In a two dimensional motion, instantaneous speed v_0 is a positive constant. Then which of the following are necessarily true?

- (a) The average velocity is not zero at any time.
- (b) Average acceleration must always vanish.
- (c) Displacements in equal time intervals are equal.
- (d) Equal path lengths are traversed in equal intervals.

4.8 In a two dimensional motion, instantaneous speed v_0 is a positive constant. Then which of the following are necessarily true?

- (a) The acceleration of the particle is zero.
- (b) The acceleration of the particle is bounded.
- (c) The acceleration of the particle is necessarily in the plane of motion.
- (d) The particle must be undergoing a uniform circular motion

4.9 Three vectors \mathbf{A}, \mathbf{B} and \mathbf{C} add up to zero. Find which is false.

- (a) $(\mathbf{A} \times \mathbf{B}) \times \mathbf{C}$ is not zero unless \mathbf{B}, \mathbf{C} are parallel
- (b) $(\mathbf{A} \times \mathbf{B}) \cdot \mathbf{C}$ is not zero unless \mathbf{B}, \mathbf{C} are parallel
- (c) If $\mathbf{A}, \mathbf{B}, \mathbf{C}$ define a plane, $(\mathbf{A} \times \mathbf{B}) \times \mathbf{C}$ is in that plane
- (d) $(\mathbf{A} \times \mathbf{B}) \cdot \mathbf{C} = |\mathbf{A}| |\mathbf{B}| |\mathbf{C}| \rightarrow C^2 = A^2 + B^2$

4.10 It is found that $|\mathbf{A} + \mathbf{B}| = |\mathbf{A}|$. This necessarily implies,

- (a) $\mathbf{B} = \mathbf{0}$
- (b) \mathbf{A}, \mathbf{B} are antiparallel
- (c) \mathbf{A}, \mathbf{B} are perpendicular
- (d) $\mathbf{A} \cdot \mathbf{B} \leq 0$

MCQ II

4.11 Two particles are projected in air with speed v_0 at angles θ_1 and θ_2 (both acute) to the horizontal, respectively. If the height reached by the first particle is greater than that of the second, then tick the right choices

- (a) angle of projection : $q_1 > q_2$
- (b) time of flight : $T_1 > T_2$
- (c) horizontal range : $R_1 > R_2$
- (d) total energy : $U_1 > U_2$.

4.12 A particle slides down a frictionless parabolic ($y = x^2$) track (A – B – C) starting from rest at point A (Fig. 4.2). Point B is at the vertex of parabola and point C is at a height less than that of point A. After C, the particle moves freely in air as a projectile. If the particle reaches highest point at P, then

- (a) KE at P = KE at B
- (b) height at P = height at A
- (c) total energy at P = total energy at A
- (d) time of travel from A to B = time of travel from B to P.

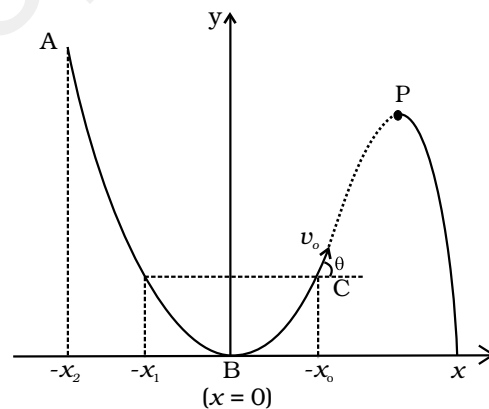

Fig. 4.2

4.13 Following are four different relations about displacement, velocity and acceleration for the motion of a particle in general. Choose the incorrect one (s) :

- (a) $\mathbf{v}_{av} = \frac{1}{2} [\mathbf{v}(t_1) + \mathbf{v}(t_2)]$
- (b) $\mathbf{v}_{av} = \frac{\mathbf{r}(t_2) - \mathbf{r}(t_1)}{t_2 - t_1}$

$$(c) \mathbf{r} = \frac{1}{2}(\mathbf{v}(t_2) - \mathbf{v}(t_1))(t_2 - t_1)$$

$$(d) \mathbf{a}_{av} = \frac{\mathbf{v}(t_2) - \mathbf{v}(t_1)}{t_2 - t_1}$$

4.14 For a particle performing uniform circular motion, choose the correct statement(s) from the following:

- (a) Magnitude of particle velocity (speed) remains constant.
- (b) Particle velocity remains directed perpendicular to radius vector.
- (c) Direction of acceleration keeps changing as particle moves.
- (d) Angular momentum is constant in magnitude but direction keeps changing.

4.15 For two vectors \mathbf{A} and \mathbf{B} , $|\mathbf{A} + \mathbf{B}| = |\mathbf{A} - \mathbf{B}|$ is always true when

- (a) $|\mathbf{A}| = |\mathbf{B}| \neq 0$
- (b) $\mathbf{A} \perp \mathbf{B}$
- (c) $|\mathbf{A}| = |\mathbf{B}| \neq 0$ and \mathbf{A} and \mathbf{B} are parallel or anti parallel
- (d) when either $|\mathbf{A}|$ or $|\mathbf{B}|$ is zero.

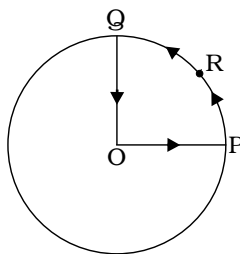

Fig. 4.3

4.16 A cyclist starts from centre O of a circular park of radius 1km and moves along the path OPRQO as shown Fig. 4.3. If he maintains constant speed of 10ms^{-1} , what is his acceleration at point R in magnitude and direction?

4.17 A particle is projected in air at some angle to the horizontal, moves along parabola as shown in Fig. 4.4, where x and y indicate horizontal and vertical directions, respectively. Show in the diagram, direction of velocity and acceleration at points A, B and C.

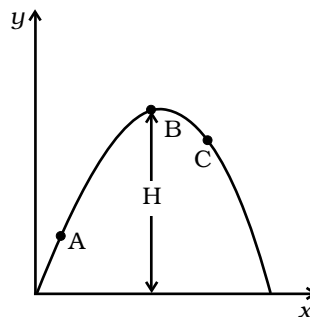

Fig. 4.4

- 4.18** A ball is thrown from a roof top at an angle of 45° above the horizontal. It hits the ground a few seconds later. At what point during its motion, does the ball have
- (a) greatest speed.
 - (b) smallest speed.
 - (c) greatest acceleration?
- Explain
- 4.19** A football is kicked into the air vertically upwards. What is its
- (a) acceleration, and (b) velocity at the highest point?
- 4.20** **A**, **B** and **C** are three non-collinear, non co-planar vectors. What can you say about direction of $\mathbf{A} \times (\mathbf{B} \times \mathbf{C})$?

SA

- 4.21** A boy travelling in an open car moving on a levelled road with constant speed tosses a ball vertically up in the air and catches it back. Sketch the motion of the ball as observed by a boy standing on the footpath. Give explanation to support your diagram.
- 4.22** A boy throws a ball in air at 60° to the horizontal along a road with a speed of 10 m/s (36km/h). Another boy sitting in a passing by car observes the ball. Sketch the motion of the ball as observed by the boy in the car, if car has a speed of (18km/h). Give explanation to support your diagram.
- 4.23** In dealing with motion of projectile in air, we ignore effect of air resistance on motion. This gives trajectory as a parabola as you have studied. What would the trajectory look like if air resistance is included? Sketch such a trajectory and explain why you have drawn it that way.
- 4.24** A fighter plane is flying horizontally at an altitude of 1.5 km with speed 720 km/h. At what angle of sight (w.r.t. horizontal) when the target is seen, should the pilot drop the bomb in order to attack the target?
- 4.25** (a) Earth can be thought of as a sphere of radius 6400 km. Any object (or a person) is performing circular motion around the axis of earth due to earth's rotation (period 1 day). What is acceleration of object on the surface of the earth (at equator) towards its centre? what is it at latitude θ ? How does these accelerations compare with $g = 9.8 \text{ m/s}^2$?

- (b) Earth also moves in circular orbit around sun once every year with an orbital radius of $1.5 \times 10^{11} \text{ m}$. What is the acceleration of earth (or any object on the surface of the earth) towards the centre of the sun? How does this acceleration compare with $g = 9.8 \text{ m/s}^2$?

(Hint : acceleration $\frac{V^2}{R} = \frac{4\pi^2 R}{T^2}$)

4.26 Given below in column I are the relations between vectors **a**, **b** and **c** and in column II are the orientations of **a**, **b** and **c** in the XY plane. Match the relation in column I to correct orientations in column II.

Column I

Column II

(a) $\mathbf{a} + \mathbf{b} = \mathbf{c}$

(i)

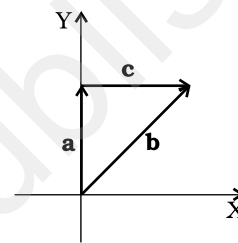

(b) $\mathbf{a} - \mathbf{c} = \mathbf{b}$

(ii)

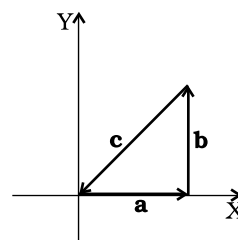

(c) $\mathbf{b} - \mathbf{a} = \mathbf{c}$

(iii)

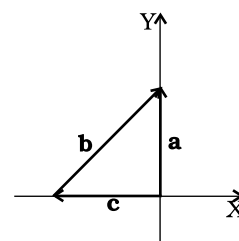

(d) $\mathbf{a} + \mathbf{b} + \mathbf{c} = 0$

(iv)

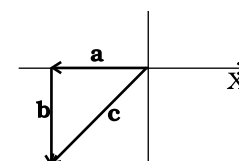

4.27 If $|\mathbf{A}| = 2$ and $|\mathbf{B}| = 4$, then match the relations in column I with the angle θ between \mathbf{A} and \mathbf{B} in column II.

Column I	Column II
(a) $\mathbf{A} \cdot \mathbf{B} = 0$	(i) $\theta = 0$
(b) $\mathbf{A} \cdot \mathbf{B} = +8$	(ii) $\theta = 90^\circ$
(c) $\mathbf{A} \cdot \mathbf{B} = 4$	(iii) $\theta = 180^\circ$
(d) $\mathbf{A} \cdot \mathbf{B} = -8$	(iv) $\theta = 60^\circ$

4.28 If $|\mathbf{A}| = 2$ and $|\mathbf{B}| = 4$, then match the relations in column I with the angle θ between \mathbf{A} and \mathbf{B} in column II

Column I	Column II
(a) $ \mathbf{A} \times \mathbf{B} = 0$	(i) $\theta = 30^\circ$
(b) $ \mathbf{A} \times \mathbf{B} = 8$	(ii) $\theta = 45^\circ$
(c) $ \mathbf{A} \times \mathbf{B} = 4$	(iii) $\theta = 90^\circ$
(d) $ \mathbf{A} \times \mathbf{B} = 4\sqrt{2}$	(iv) $\theta = 0^\circ$

LA

4.29 A hill is 500 m high. Supplies are to be sent across the hill using a canon that can hurl packets at a speed of 125 m/s over the hill. The canon is located at a distance of 800m from the foot of hill and can be moved on the ground at a speed of 2 m/s; so that its distance from the hill can be adjusted. What is the shortest time in which a packet can reach on the ground across the hill? Take $g = 10 \text{ m/s}^2$.

4.30 A gun can fire shells with maximum speed v_0 and the maximum horizontal range that can be achieved is $R = \frac{v_0^2}{g}$.

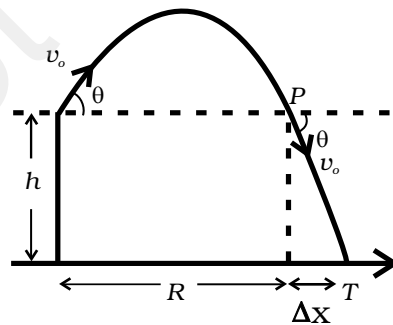

Fig 4.5

If a target farther away by distance Δx (beyond R) has to be hit with the same gun (Fig 4.5), show that it could be achieved by raising the gun to a height at least

$$h = \Delta x \left[1 + \frac{\Delta x}{R} \right]$$

(Hint : This problem can be approached in two different ways:

- (i) Refer to the diagram: target T is at horizontal distance $x = R + \Delta x$ and below point of projection $y = -h$.
- (ii) From point P in the diagram: Projection at speed v_0 at an angle θ below horizontal with height h and horizontal range Δx .)

4.31 A particle is projected in air at an angle β to a surface which itself is inclined at an angle α to the horizontal (Fig. 4.6).

- (a) Find an expression of range on the plane surface (distance on the plane from the point of projection at which particle will hit the surface).
- (b) Time of flight.
- (c) β at which range will be maximum.

Fig. 4.6

(Hint : This problem can be solved in two different ways:

- (i) Point P at which particle hits the plane can be seen as intersection of its trajectory (parabola) and straight line. Remember particle is projected at an angle $(\alpha + \beta)$ w.r.t. horizontal.
- (ii) We can take x -direction along the plane and y -direction perpendicular to the plane. In that case resolve g (acceleration due to gravity) in two different components, g_x along the plane and g_y perpendicular to the plane. Now the problem can be solved as two independent motions in x and y directions respectively with time as a common parameter.)

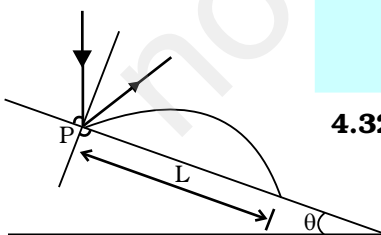

Fig 4.7

4.32 A particle falling vertically from a height hits a plane surface inclined to horizontal at an angle θ with speed v_0 and rebounds elastically (Fig 4.7). Find the distance along the plane where it will hit second time.

- (Hint: (i) After rebound, particle still has speed V_0 to start.
 (ii) Work out angle particle speed has with horizontal after it rebounds.
 (iii) Rest is similar to if particle is projected up the incline.)

4.33 A girl riding a bicycle with a speed of 5 m/s towards north direction, observes rain falling vertically down. If she increases her speed to 10 m/s, rain appears to meet her at 45° to the vertical. What is the speed of the rain? In what direction does rain fall as observed by a ground based observer?

(Hint: Assume north to be \hat{i} direction and vertically downward to be $-\hat{j}$. Let the rain velocity \mathbf{v}_r be $a\hat{i}+b\hat{j}$. The velocity of rain as observed by the girl is always $\mathbf{v}_r - \mathbf{v}_{girl}$. Draw the vector diagram/s for the information given and find a and b . You may draw all vectors in the reference frame of ground based observer.)

4.34 A river is flowing due east with a speed 3m/s. A swimmer can swim in still water at a speed of 4 m/s (Fig. 4.8).

- If swimmer starts swimming due north, what will be his resultant velocity (magnitude and direction)?
- If he wants to start from point A on south bank and reach opposite point B on north bank,
 - which direction should he swim?
 - what will be his resultant speed?
- From two different cases as mentioned in (a) and (b) above, in which case will he reach opposite bank in shorter time?

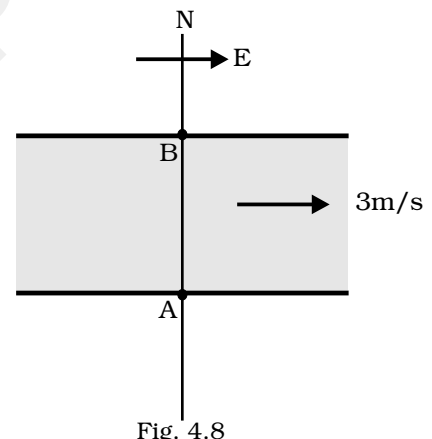

Fig. 4.8

4.35 A cricket felder can throw the cricket ball with a speed v_0 . If he throws the ball while running with speed u at an angle θ to the horizontal, find

- the effective angle to the horizontal at which the ball is projected in air as seen by a spectator.
- what will be time of flight?
- what is the distance (horizontal range) from the point of projection at which the ball will land?

- (d) find θ at which he should throw the ball that would maximise the horizontal range as found in (iii).
 (e) how does θ for maximum range change if $u > v_0$, $u = v_0$, $u < v_0$?
 (f) how does θ in (v) compare with that for $u = 0$ (i.e. 45°)?

4.36 Motion in two dimensions, in a plane can be studied by expressing position, velocity and acceleration as vectors in Cartesian co-ordinates $\mathbf{A} = A_x \hat{\mathbf{i}} + A_y \hat{\mathbf{j}}$ where $\hat{\mathbf{i}}$ and $\hat{\mathbf{j}}$ are unit vector along x and y directions, respectively and A_x and A_y are corresponding components of \mathbf{A} (Fig. 4.9). Motion can also be studied by expressing vectors in circular polar co-ordinates as $\mathbf{A} = A_r \hat{\mathbf{r}} + A_\theta \hat{\boldsymbol{\theta}}$ where $\hat{\mathbf{r}} = \frac{\mathbf{r}}{r} = \cos \theta \hat{\mathbf{i}} + \sin \theta \hat{\mathbf{j}}$ and $\hat{\boldsymbol{\theta}} = -\sin \theta \hat{\mathbf{i}} + \cos \theta \hat{\mathbf{j}}$ are unit vectors along direction in which 'r' and ' θ ' are increasing.

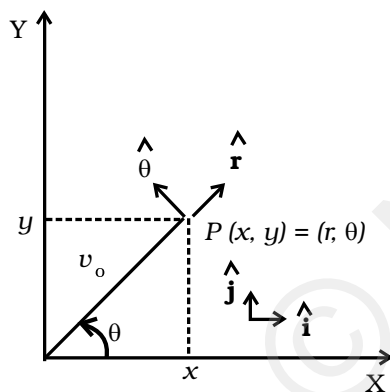

Fig. 4.9

- (a) Express $\hat{\mathbf{i}}$ and $\hat{\mathbf{j}}$ in terms of $\hat{\mathbf{r}}$ and $\hat{\boldsymbol{\theta}}$
 (b) Show that both $\hat{\mathbf{r}}$ and $\hat{\boldsymbol{\theta}}$ are unit vectors and are perpendicular to each other.
 (c) Show that $\frac{d}{dt}(\hat{\mathbf{r}}) = \omega \hat{\boldsymbol{\theta}}$ where

$$\omega = \frac{d\theta}{dt} \text{ and } \frac{d}{dt}(\hat{\boldsymbol{\theta}}) = -\omega \hat{\mathbf{r}}$$

 (d) For a particle moving along a spiral given by $\mathbf{r} = a\theta \hat{\mathbf{r}}$, where $a = 1$ (unit), find dimensions of 'a'.
 (e) Find velocity and acceleration in polar vector representation for particle moving along spiral described in (d) above.

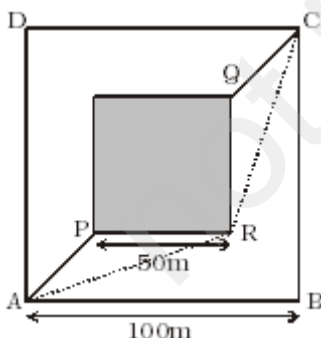

Fig. 4.10

4.37 A man wants to reach from A to the opposite corner of the square C (Fig. 4.10). The sides of the square are 100 m. A central square of 50m \times 50m is filled with sand. Outside this square, he can walk at a speed 1 m/s. In the central square, he can walk only at a speed of v m/s ($v < 1$). What is smallest value of v for which he can reach faster via a straight path through the sand than any path in the square outside the sand?

Chapter Five

LAWS OF MOTION



MCQ I

- 5.1** A ball is travelling with uniform translatory motion. This means that
- (a) it is at rest.
 - (b) the path can be a straight line or circular and the ball travels with uniform speed.
 - (c) all parts of the ball have the same velocity (magnitude and direction) and the velocity is constant.
 - (d) the centre of the ball moves with constant velocity and the ball spins about its centre uniformly.
- 5.2** A metre scale is moving with uniform velocity. This implies
- (a) the force acting on the scale is zero, but a torque about the centre of mass can act on the scale.
 - (b) the force acting on the scale is zero and the torque acting about centre of mass of the scale is also zero.

- (c) the total force acting on it need not be zero but the torque on it is zero.
- (d) neither the force nor the torque need to be zero.
- 5.3** A cricket ball of mass 150 g has an initial velocity $\mathbf{u} = (3\hat{\mathbf{i}} + 4\hat{\mathbf{j}}) \text{ m s}^{-1}$ and a final velocity $\mathbf{v} = -(3\hat{\mathbf{i}} + 4\hat{\mathbf{j}}) \text{ m s}^{-1}$ after being hit. The change in momentum (final momentum-initial momentum) is (in kg m s^{-1})
- (a) zero
- (b) $-(0.45\hat{\mathbf{i}} + 0.6\hat{\mathbf{j}})$
- (c) $-(0.9\hat{\mathbf{i}} + 1.2\hat{\mathbf{j}})$
- (d) $-5(\hat{\mathbf{i}} + \hat{\mathbf{j}})$.
- 5.4** In the previous problem (5.3), the magnitude of the momentum transferred during the hit is
- (a) Zero (b) 0.75 kg m s^{-1} (c) 1.5 kg m s^{-1} (d) 14 kg m s^{-1} .
- 5.5** Conservation of momentum in a collision between particles can be understood from
- (a) conservation of energy.
- (b) Newton's first law only.
- (c) Newton's second law only.
- (d) both Newton's second and third law.
- 5.6** A hockey player is moving northward and suddenly turns westward with the same speed to avoid an opponent. The force that acts on the player is
- (a) frictional force along westward.
- (b) muscle force along southward.
- (c) frictional force along south-west.
- (d) muscle force along south-west.
- 5.7** A body of mass 2kg travels according to the law $x(t) = pt + qt^2 + rt^3$ where $p = 3 \text{ m s}^{-1}$, $q = 4 \text{ m s}^{-2}$ and $r = 5 \text{ m s}^{-3}$.
- The force acting on the body at $t = 2$ seconds is
- (a) 136 N
- (b) 134 N
- (c) 158 N
- (d) 68 N

- 5.8** A body with mass 5 kg is acted upon by a force $\mathbf{F} = (-3\hat{\mathbf{i}} + 4\hat{\mathbf{j}})$ N. If its initial velocity at $t = 0$ is $\mathbf{v} = (6\hat{\mathbf{i}} - 12\hat{\mathbf{j}})$ m s⁻¹, the time at which it will just have a velocity along the y -axis is
- never
 - 10 s
 - 2 s
 - 15 s
- 5.9** A car of mass m starts from rest and acquires a velocity along east $\mathbf{v} = v\hat{\mathbf{i}}$ ($v > 0$) in two seconds. Assuming the car moves with uniform acceleration, the force exerted on the car is
- $\frac{mv}{2}$ eastward and is exerted by the car engine.
 - $\frac{mv}{2}$ eastward and is due to the friction on the tyres exerted by the road.
 - more than $\frac{mv}{2}$ eastward exerted due to the engine and overcomes the friction of the road.
 - $\frac{mv}{2}$ exerted by the engine .

MCQ II

- 5.10** The motion of a particle of mass m is given by $x = 0$ for $t < 0$ s, $x(t) = A \sin 4\pi t$ for $0 < t < (1/4)$ s ($A > 0$), and $x = 0$ for $t > (1/4)$ s. Which of the following statements is true?
- The force at $t = (1/8)$ s on the particle is $-16\pi^2 A m$.
 - The particle is acted upon by an impulse of magnitude $4\pi^2 A m$ at $t = 0$ s and $t = (1/4)$ s.
 - The particle is not acted upon by any force.
 - The particle is not acted upon by a constant force.
 - There is no impulse acting on the particle.
- 5.11** In Fig. 5.1, the co-efficient of friction between the floor and the body B is 0.1. The co-efficient of friction between the bodies B and A is 0.2. A force \mathbf{F} is applied as shown

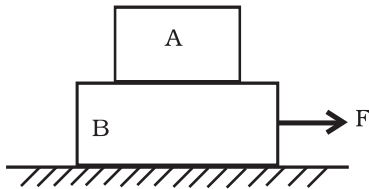

Fig. 5.1

on B. The mass of A is $m/2$ and of B is m . Which of the following statements are true?

- (a) The bodies will move together if $F = 0.25 mg$.
- (b) The body A will slip with respect to B if $F = 0.5 mg$.
- (c) The bodies will move together if $F = 0.5 mg$.
- (d) The bodies will be at rest if $F = 0.1 mg$.
- (e) The maximum value of F for which the two bodies will move together is $0.45 mg$.

5.12 Mass m_1 moves on a slope making an angle θ with the horizontal and is attached to mass m_2 by a string passing over a frictionless pulley as shown in Fig. 5.2. The co-efficient of friction between m_1 and the sloping surface is μ .

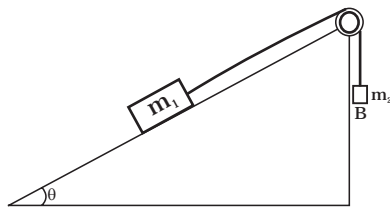

Fig. 5.2

Which of the following statements are true?

- (a) If $m_2 > m_1 \sin \theta$, the body will move up the plane.
- (b) If $m_2 > m_1 (\sin \theta + \mu \cos \theta)$, the body will move up the plane.
- (c) If $m_2 < m_1 (\sin \theta + \mu \cos \theta)$, the body will move up the plane.
- (d) If $m_2 < m_1 (\sin \theta - \mu \cos \theta)$, the body will move down the plane.

5.13 In Fig. 5.3, a body A of mass m slides on plane inclined at angle θ_1 to the horizontal and μ_1 is the coefficient of friction between A and the plane. A is connected by a light string passing over a frictionless pulley to another body B, also of mass m , sliding on a frictionless plane inclined at angle θ_2 to the horizontal. Which of the following statements are true?

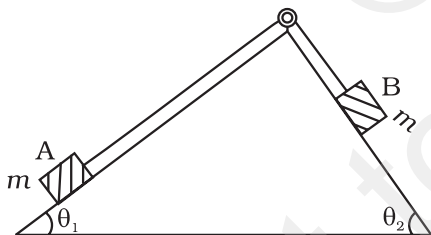

Fig. 5.3

- (a) A will never move up the plane.
- (b) A will just start moving up the plane when

$$\mu = \frac{\sin \theta_2 - \sin \theta_1}{\cos \theta_1}$$

- (c) For A to move up the plane, θ_2 must always be greater than θ_1 .
- (d) B will always slide down with constant speed.

5.14 Two billiard balls A and B, each of mass $50g$ and moving in opposite directions with speed of $5m s^{-1}$ each, collide and rebound with the same speed. If the collision lasts for $10^{-3} s$, which of the following statements are true?

- (a) The impulse imparted to each ball is $0.25 m s^{-1}$ and the force on each ball is $250 N$.

- (b) The impulse imparted to each ball is 0.25 kg m s^{-1} and the force exerted on each ball is $25 \times 10^{-5} \text{ N}$.
- (c) The impulse imparted to each ball is 0.5 N s .
- (d) The impulse and the force on each ball are equal in magnitude and opposite in direction.

5.15 A body of mass 10 kg is acted upon by two perpendicular forces, 6 N and 8 N . The resultant acceleration of the body is

- (a) 1 m s^{-2} at an angle of $\tan^{-1}\left(\frac{4}{3}\right)$ w.r.t. 6 N force.
- (b) 0.2 m s^{-2} at an angle of $\tan^{-1}\left(\frac{4}{3}\right)$ w.r.t. 6 N force.
- (c) 1 m s^{-2} at an angle of $\tan^{-1}\left(\frac{3}{4}\right)$ w.r.t. 8 N force.
- (d) 0.2 m s^{-2} at an angle of $\tan^{-1}\left(\frac{3}{4}\right)$ w.r.t. 8 N force.

VSA

- 5.16** A girl riding a bicycle along a straight road with a speed of 5 m s^{-1} throws a stone of mass 0.5 kg which has a speed of 15 m s^{-1} with respect to the ground along her direction of motion. The mass of the girl and bicycle is 50 kg . Does the speed of the bicycle change after the stone is thrown? What is the change in speed, if so?
- 5.17** A person of mass 50 kg stands on a weighing scale on a lift. If the lift is descending with a downward acceleration of 9 m s^{-2} , what would be the reading of the weighing scale? ($g = 10 \text{ m s}^{-2}$)
- 5.18** The position time graph of a body of mass 2 kg is as given in Fig. 5.4. What is the impulse on the body at $t = 0 \text{ s}$ and $t = 4 \text{ s}$.

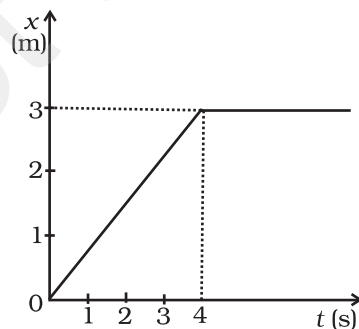

Fig. 5.4

- 5.19** A person driving a car suddenly applies the brakes on seeing a child on the road ahead. If he is not wearing seat belt, he falls forward and hits his head against the steering wheel. Why?
- 5.20** The velocity of a body of mass 2 kg as a function of t is given by $\mathbf{v}(t) = 2t \hat{\mathbf{i}} + t^2 \hat{\mathbf{j}}$. Find the momentum and the force acting on it, at time $t = 2\text{s}$.
- 5.21** A block placed on a rough horizontal surface is pulled by a horizontal force F . Let f be the force applied by the rough surface on the block. Plot a graph of f versus F .
- 5.22** Why are porcelain objects wrapped in paper or straw before packing for transportation?
- 5.23** Why does a child feel more pain when she falls down on a hard cement floor, than when she falls on the soft muddy ground in the garden?
- 5.24** A woman throws an object of mass 500 g with a speed of 25 m s^{-1} .
- (a) What is the impulse imparted to the object?
- (b) If the object hits a wall and rebounds with half the original speed, what is the change in momentum of the object?
- 5.25** Why are mountain roads generally made winding upwards rather than going straight up?

SA

- 5.26** A mass of 2kg is suspended with thread AB (Fig. 5.5). Thread CD of the same type is attached to the other end of 2 kg mass. Lower thread is pulled gradually, harder and harder in the downward direction so as to apply force on AB. Which of the threads will break and why?
- 5.27** In the above given problem if the lower thread is pulled with a jerk, what happens?
- 5.28** Two masses of 5 kg and 3 kg are suspended with help of massless inextensible strings as shown in Fig. 5.6. Calculate T_1 and T_2 when whole system is going upwards with acceleration = 2 m s^{-2} (use $g = 9.8 \text{ m s}^{-2}$).

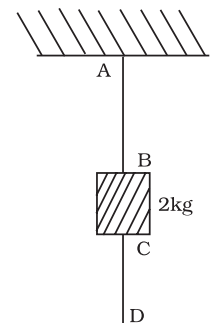

Fig. 5.5

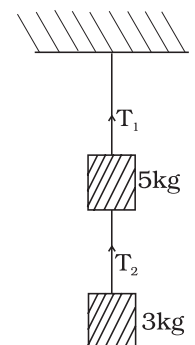

Fig. 5.6

5.29 Block A of weight 100 N rests on a frictionless inclined plane of slope angle 30° (Fig. 5.7). A flexible cord attached to A passes over a frictionless pulley and is connected to block B of weight W. Find the weight W for which the system is in equilibrium.

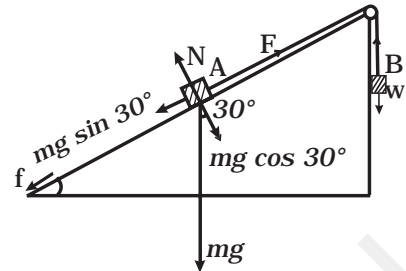

Fig. 5.7

5.30 A block of mass M is held against a rough vertical wall by pressing it with a finger. If the coefficient of friction between the block and the wall is μ and the acceleration due to gravity is g , calculate the minimum force required to be applied by the finger to hold the block against the wall?

5.31 A 100 kg gun fires a ball of 1 kg horizontally from a cliff of height 500m. It falls on the ground at a distance of 400m from the bottom of the cliff. Find the recoil velocity of the gun. (acceleration due to gravity = 10 m s^{-2})

5.32 Figure 5.8 shows (x, t) , (y, t) diagram of a particle moving in 2-dimensions.

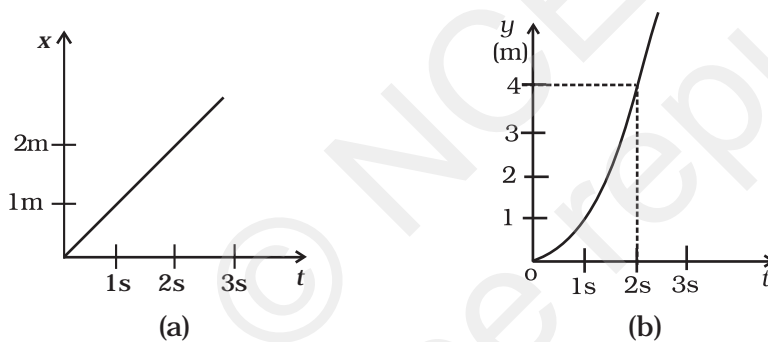

Fig. 5.8

If the particle has a mass of 500 g, find the force (direction and magnitude) acting on the particle.

5.33 A person in an elevator accelerating upwards with an acceleration of 2 m s^{-2} , tosses a coin vertically upwards with a speed of 20 m s^{-1} . After how much time will the coin fall back into his hand? ($g = 10 \text{ m s}^{-2}$)

LA

5.34 There are three forces \mathbf{F}_1 , \mathbf{F}_2 and \mathbf{F}_3 acting on a body, all acting on a point P on the body. The body is found to move with uniform speed.

- Show that the forces are coplanar.
- Show that the torque acting on the body about any point due to these three forces is zero.

5.35 When a body slides down from rest along a smooth inclined plane making an angle of 45° with the horizontal, it takes time T . When the same body slides down from rest along a rough inclined plane making the same angle and through the same distance, it is seen to take time pT , where p is some number greater than 1. Calculate the co-efficient of friction between the body and the rough plane.

5.36 Figure 5.9 shows (v_x, t) and (v_y, t) diagrams for a body of unit mass. Find the force as a function of time.

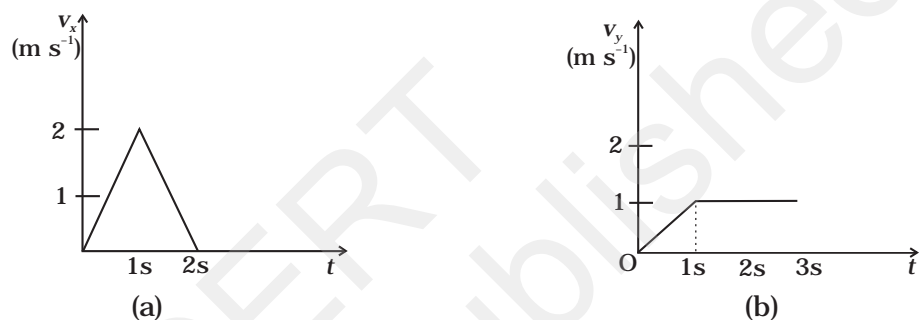

Fig. 5.9

5.37 A racing car travels on a track (without banking) ABCDEFA (Fig. 5.10). ABC is a circular arc of radius $2R$. CD and FA are straight paths of length R and DEF is a circular arc of radius R . The co-efficient of friction on the road is $\mu = 0.1$. The maximum speed of the car is 50 m s^{-1} . Find the minimum time for completing one round.

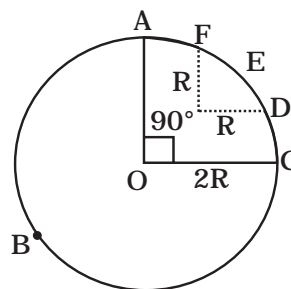

Fig. 5.10

5.38 The displacement vector of a particle of mass m is given by $\mathbf{r}(t) = \hat{\mathbf{i}} A \cos \omega t + \hat{\mathbf{j}} B \sin \omega t$.

- Show that the trajectory is an ellipse.
- Show that $\mathbf{F} = -m\omega^2 \mathbf{r}$.

5.39 A cricket bowler releases the ball in two different ways

- giving it only horizontal velocity, and
- giving it horizontal velocity and a small downward velocity.

The speed v_s at the time of release is the same. Both are released at a height H from the ground. Which one will have greater speed when the ball hits the ground? Neglect air resistance.

5.40 There are four forces acting at a point P produced by strings as shown in Fig. 5.11, which is at rest. Find the forces F_1 and F_2 .

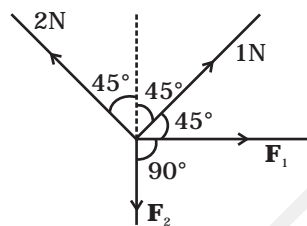

Fig. 5.11

5.41 A rectangular box lies on a rough inclined surface. The co-efficient of friction between the surface and the box is μ . Let the mass of the box be m .

- At what angle of inclination θ of the plane to the horizontal will the box just start to slide down the plane?
- What is the force acting on the box down the plane, if the angle of inclination of the plane is increased to $\alpha > \theta$?
- What is the force needed to be applied upwards along the plane to make the box either remain stationary or just move up with uniform speed?
- What is the force needed to be applied upwards along the plane to make the box move up the plane with acceleration a ?

5.42 A helicopter of mass 2000kg rises with a vertical acceleration of 15 m s^{-2} . The total mass of the crew and passengers is 500 kg. Give the magnitude and direction of the ($g = 10 \text{ m s}^{-2}$)

- force on the floor of the helicopter by the crew and passengers.
- action of the rotor of the helicopter on the surrounding air.
- force on the helicopter due to the surrounding air.

Chapter Six

WORK, ENERGY AND POWER



MCQ I

- 6.1** An electron and a proton are moving under the influence of mutual forces. In calculating the change in the kinetic energy of the system during motion, one ignores the magnetic force of one on another. This is because,
- (a) the two magnetic forces are equal and opposite, so they produce no net effect.
 - (b) the magnetic forces do no work on each particle.
 - (c) the magnetic forces do equal and opposite (but non-zero) work on each particle.
 - (d) the magnetic forces are necessarily negligible.
- 6.2** A proton is kept at rest. A positively charged particle is released from rest at a distance d in its field. Consider two experiments; one in which the charged particle is also a proton and in another, a positron. In the same time t , the work done on the two moving charged particles is

- (a) same as the same force law is involved in the two experiments.
 (b) less for the case of a positron, as the positron moves away more rapidly and the force on it weakens.
 (c) more for the case of a positron, as the positron moves away a larger distance.
 (d) same as the work done by charged particle on the stationary proton.
- 6.3** A man squatting on the ground gets straight up and stand. The force of reaction of ground on the man during the process is
- (a) constant and equal to mg in magnitude.
 (b) constant and greater than mg in magnitude.
 (c) variable but always greater than mg .
 (d) at first greater than mg , and later becomes equal to mg .
- 6.4** A bicyclist comes to a skidding stop in 10 m. During this process, the force on the bicycle due to the road is 200N and is directly opposed to the motion. The work done by the cycle on the road is
- (a) + 2000J
 (b) - 200J
 (c) zero
 (d) - 20,000J
- 6.5** A body is falling freely under the action of gravity alone in vacuum. Which of the following quantities remain constant during the fall?
- (a) Kinetic energy.
 (b) Potential energy.
 (c) Total mechanical energy.
 (d) Total linear momentum.
- 6.6** During inelastic collision between two bodies, which of the following quantities always remain conserved?
- (a) Total kinetic energy.
 (b) Total mechanical energy.
 (c) Total linear momentum.
 (d) Speed of each body.
- 6.7** Two inclined frictionless tracks, one gradual and the other steep meet at A from where two stones are allowed to slide down from rest, one on each track as shown in Fig. 6.1.
- Which of the following statement is correct?
- (a) Both the stones reach the bottom at the same time but not with the same speed.
 (b) Both the stones reach the bottom with the same speed and stone I reaches the bottom earlier than stone II.

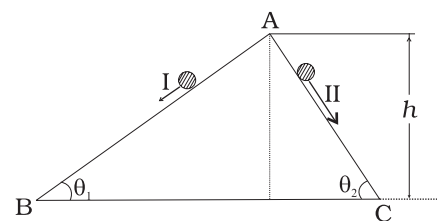

Fig. 6.1

- (c) Both the stones reach the bottom with the same speed and stone II reaches the bottom earlier than stone I.
 (d) Both the stones reach the bottom at different times and with different speeds.

6.8 The potential energy function for a particle executing linear SHM is given by $V(x) = \frac{1}{2}kx^2$ where k is the force constant of the oscillator (Fig. 6.2).

For $k = 0.5\text{N/m}$, the graph of $V(x)$ versus x is shown in the figure. A particle of total energy E turns back when it reaches $x = \pm x_m$. If V and K indicate the P.E. and K.E., respectively of the particle at $x = +x_m$, then which of the following is correct?

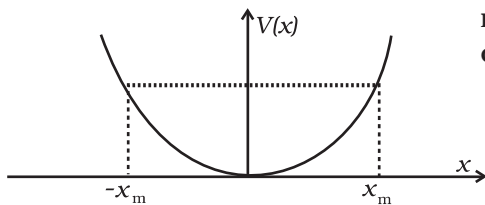

Fig. 6.2

- (a) $V = 0, K = E$
 (b) $V = E, K = 0$
 (c) $V < E, K = 0$
 (d) $V = 0, K < E$

6.9 Two identical ball bearings in contact with each other and resting on a frictionless table are hit head-on by another ball bearing of the same mass moving initially with a speed V as shown in Fig. 6.3.

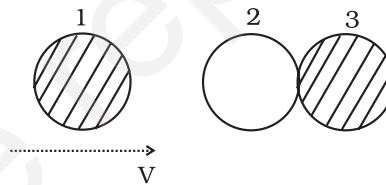

Fig. 6.3

If the collision is elastic, which of the following (Fig. 6.4) is a possible result after collision?

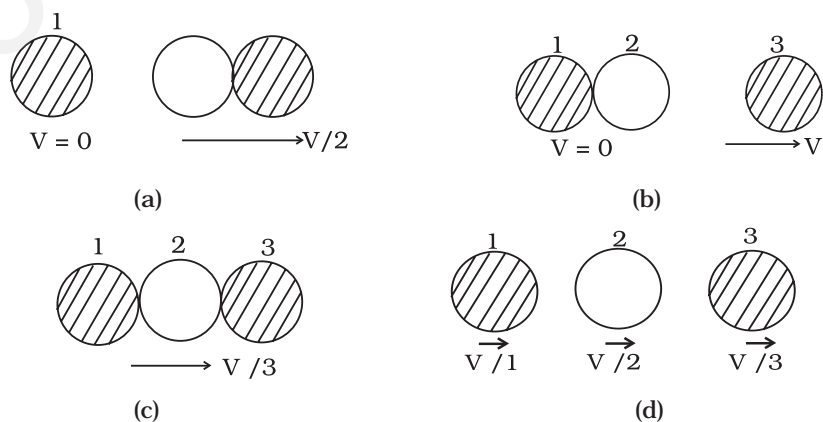

Fig. 6.4

6.10 A body of mass 0.5 kg travels in a straight line with velocity $v = a x^{3/2}$ where $a = 5 \text{ m}^{-1/2} \text{ s}^{-1}$. The work done by the net force during its displacement from $x = 0$ to $x = 2 \text{ m}$ is

- (a) 1.5 J
- (b) 50 J
- (c) 10 J
- (d) 100 J

6.11 A body is moving unidirectionally under the influence of a source of constant power supplying energy. Which of the diagrams shown in Fig. 6.5 correctly shows the displacement-time curve for its motion?

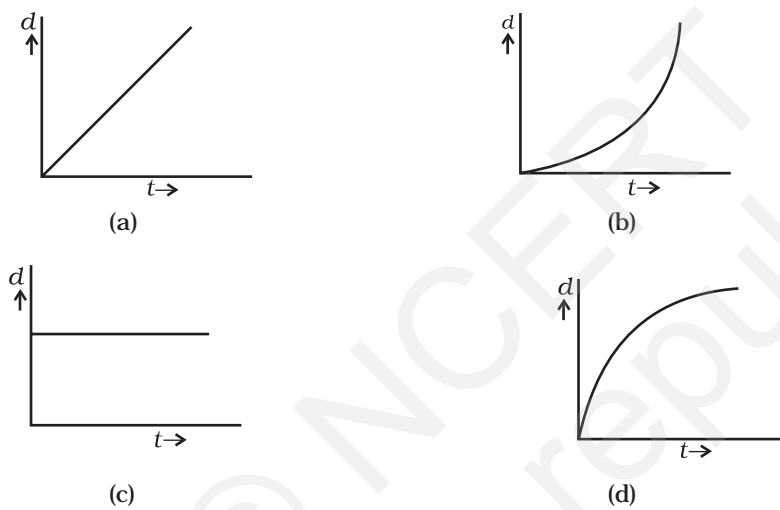

Fig. 6.5

6.12 Which of the diagrams shown in Fig. 6.6 most closely shows the variation in kinetic energy of the earth as it moves once around the sun in its elliptical orbit?

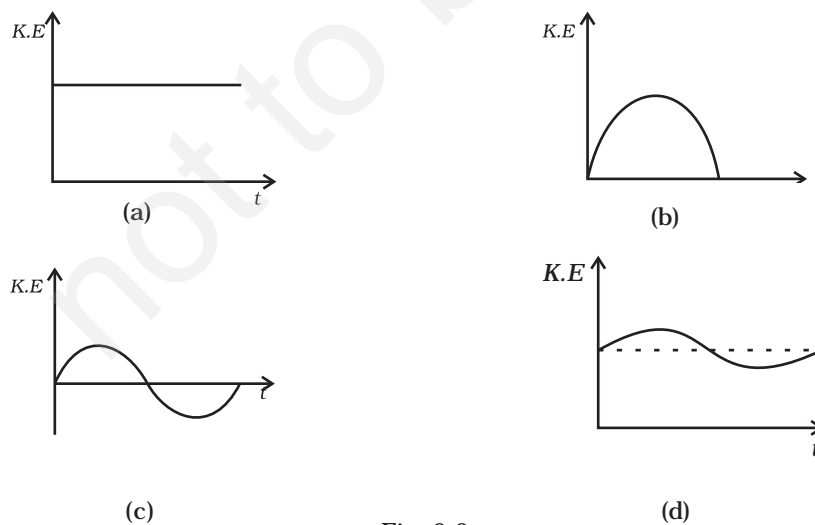

Fig. 6.6

6.13 Which of the diagrams shown in Fig. 6.7 represents variation of total mechanical energy of a pendulum oscillating in air as function of time?

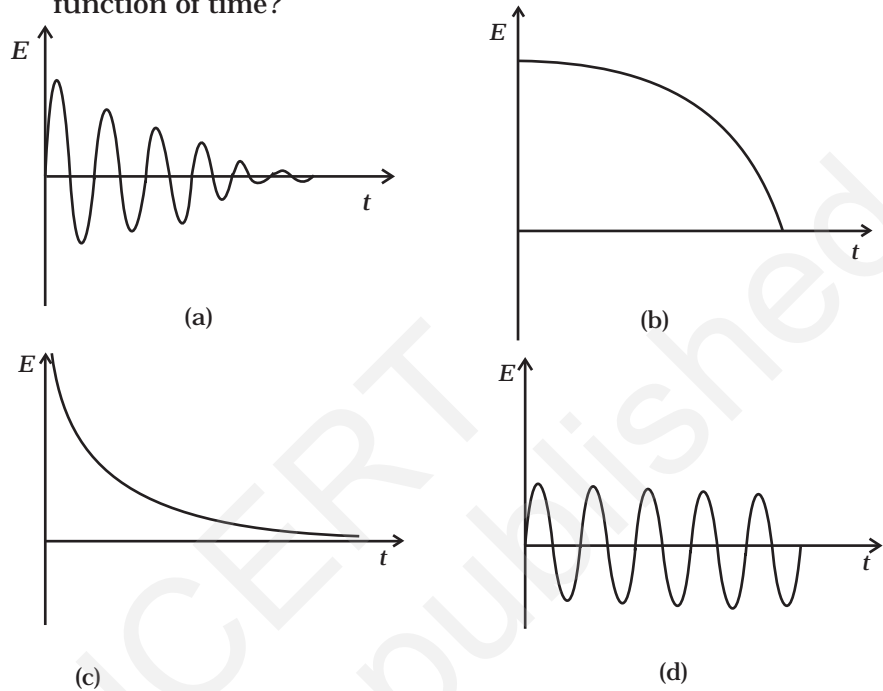
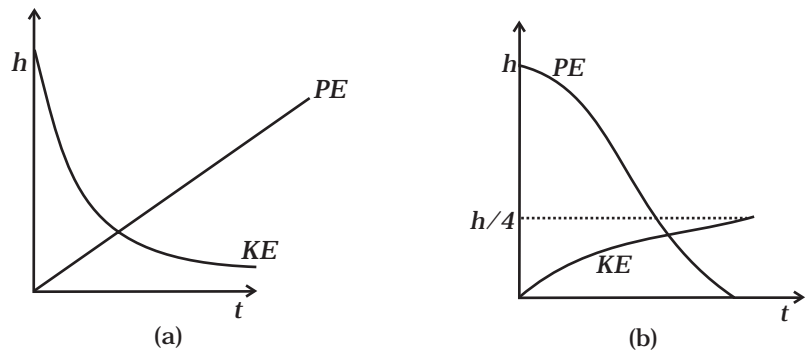

Fig. 6.7

6.14 A mass of 5 kg is moving along a circular path of radius 1 m. If the mass moves with 300 revolutions per minute, its kinetic energy would be

- (a) $250\pi^2$
- (b) $100\pi^2$
- (c) $5\pi^2$
- (d) 0

6.15 A raindrop falling from a height h above ground, attains a near terminal velocity when it has fallen through a height $(3/4)h$. Which of the diagrams shown in Fig. 6.8 correctly shows the change in kinetic and potential energy of the drop during its fall up to the ground?



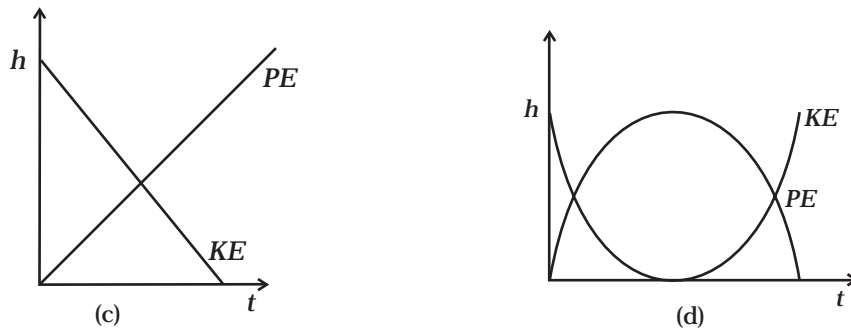

Fig. 6.8

6.16 In a shotput event an athlete throws the shotput of mass 10 kg with an initial speed of 1 m s^{-1} at 45° from a height 1.5 m above ground. Assuming air resistance to be negligible and acceleration due to gravity to be 10 m s^{-2} , the kinetic energy of the shotput when it just reaches the ground will be

- (a) 2.5 J
- (b) 5.0 J
- (c) 52.5 J
- (d) 155.0 J

6.17 Which of the diagrams in Fig. 6.9 correctly shows the change in kinetic energy of an iron sphere falling freely in a lake having sufficient depth to impart it a terminal velocity?

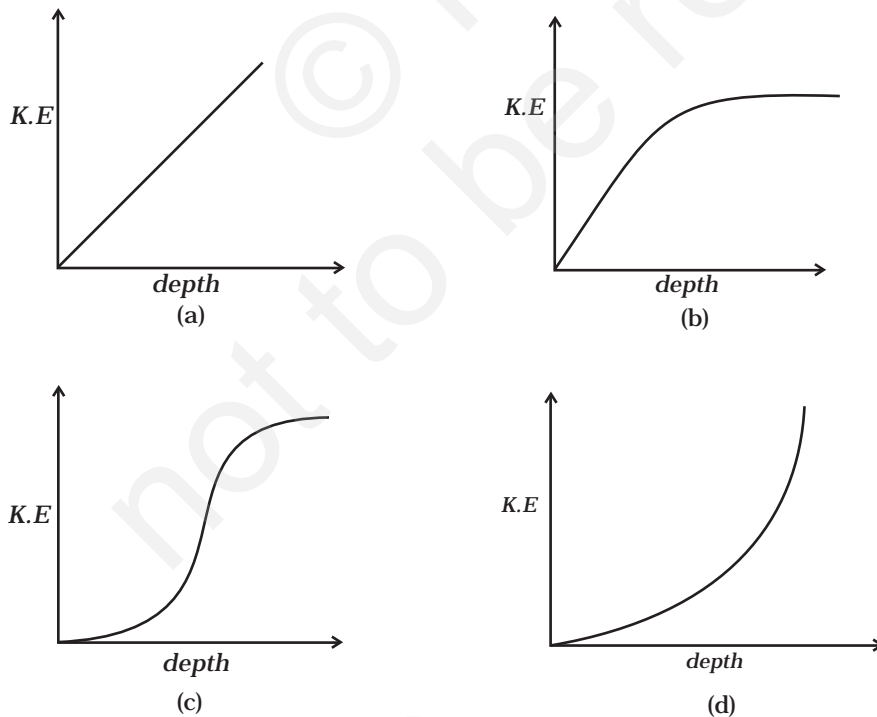

Fig. 6.9

- 6.18** A cricket ball of mass 150 g moving with a speed of 126 km/h hits at the middle of the bat, held firmly at its position by the batsman. The ball moves straight back to the bowler after hitting the bat. Assuming that collision between ball and bat is completely elastic and the two remain in contact for 0.001s, the force that the batsman had to apply to hold the bat firmly at its place would be
- 10.5 N
 - 21 N
 - 1.05×10^4 N
 - 2.1×10^4 N

MCQ II

- 6.19** A man, of mass m , standing at the bottom of the staircase, of height L climbs it and stands at its top.
- Work done by all forces on man is equal to the rise in potential energy mgL .
 - Work done by *all* forces on man is zero.
 - Work done by the gravitational force on man is mgL .
 - The reaction force from a step does not do work because the point of application of the force does not move while the force exists.
- 6.20** A bullet of mass m fired at 30° to the horizontal leaves the barrel of the gun with a velocity v . The bullet hits a soft target at a height h above the ground while it is moving downward and emerges out with half the kinetic energy it had before hitting the target.
- Which of the following statements are correct in respect of bullet after it emerges out of the target?
- The velocity of the bullet will be reduced to half its initial value.
 - The velocity of the bullet will be more than half of its earlier velocity.
 - The bullet will continue to move along the same parabolic path.
 - The bullet will move in a different parabolic path.
 - The bullet will fall vertically downward after hitting the target.
 - The internal energy of the particles of the target will increase.
- 6.21** Two blocks M_1 and M_2 having equal mass are free to move on a horizontal frictionless surface. M_2 is attached to a massless spring as shown in Fig. 6.10. Initially M_2 is at rest and M_1 is moving toward M_2 with speed v and collides head-on with M_2 .
- While spring is fully compressed all the KE of M_1 is stored as PE of spring.

- (b) While spring is fully compressed the system momentum is not conserved, though final momentum is equal to initial momentum.
- (c) If spring is massless, the final state of the M_1 is state of rest.
- (d) If the surface on which blocks are moving has friction, then collision cannot be elastic.



Fig. 6.10

VSA

- 6.22** A rough inclined plane is placed on a cart moving with a constant velocity u on horizontal ground. A block of mass M rests on the incline. Is any work done by force of friction between the block and incline? Is there then a dissipation of energy?
- 6.23** Why is electrical power required at all when the elevator is descending? Why should there be a limit on the number of passengers in this case?
- 6.24** A body is being raised to a height h from the surface of earth. What is the sign of work done by
- applied force
 - gravitational force?
- 6.25** Calculate the work done by a car against gravity in moving along a straight horizontal road. The mass of the car is 400 kg and the distance moved is 2m.
- 6.26** A body falls towards earth in air. Will its total mechanical energy be conserved during the fall? Justify.
- 6.27** A body is moved along a closed loop. Is the work done in moving the body necessarily zero? If not, state the condition under which work done over a closed path is always zero.
- 6.28** In an elastic collision of two billiard balls, which of the following quantities remain conserved during the short time of collision of the balls (i.e., when they are in contact).
- Kinetic energy.
 - Total linear momentum?
- Give reason for your answer in each case.
- 6.29** Calculate the power of a crane in watts, which lifts a mass of 100 kg to a height of 10 m in 20s.

- 6.30** The average work done by a human heart while it beats once is 0.5 J. Calculate the power used by heart if it beats 72 times in a minute.
- 6.31** Give example of a situation in which an applied force does not result in a change in kinetic energy.
- 6.32** Two bodies of unequal mass are moving in the same direction with equal kinetic energy. The two bodies are brought to rest by applying retarding force of same magnitude. How would the distance moved by them before coming to rest compare?

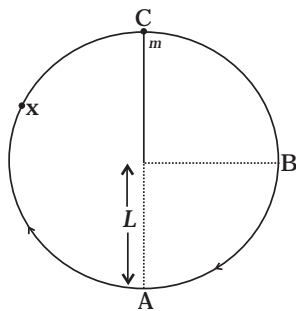

Fig. 6.11

- 6.33** A bob of mass m suspended by a light string of length L is whirled into a vertical circle as shown in Fig. 6.11. What will be the trajectory of the particle if the string is cut at
- Point B?
 - Point C?
 - Point X?

SA

- 6.34** A graph of potential energy $V(x)$ versus x is shown in Fig. 6.12. A particle of energy E_0 is executing motion in it. Draw graph of velocity and kinetic energy versus x for one complete cycle AFA.

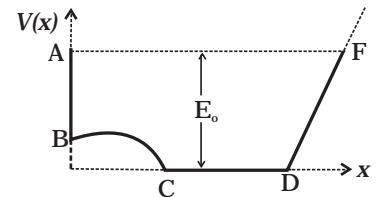

Fig. 6.12

- 6.35** A ball of mass m , moving with a speed $2v_0$, collides inelastically ($e > 0$) with an identical ball at rest. Show that
- For head-on collision, both the balls move forward.
 - For a general collision, the angle between the two velocities of scattered balls is less than 90° .

- 6.36** Consider a one-dimensional motion of a particle with total energy E . There are four regions A, B, C and D in which the relation between potential energy V , kinetic energy (K) and total energy E is as given below:

Region A : $V > E$

Region B : $V < E$

Region C : $K > E$

Region D : $V > K$

State with reason in each case whether a particle can be found in the given region or not.

- 6.37** The bob A of a pendulum released from horizontal to the vertical hits another bob B of the same mass at rest on a table as shown in Fig. 6.13.

If the length of the pendulum is 1 m, calculate

- the height to which bob A will rise after collision.
 - the speed with which bob B starts moving.
- Neglect the size of the bobs and assume the collision to be elastic.

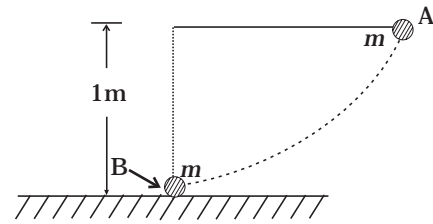

Fig. 6.13

- 6.38** A raindrop of mass 1.00 g falling from a height of 1 km hits the ground with a speed of 50 m s^{-1} . Calculate

- the loss of P.E. of the drop.
- the gain in K.E. of the drop.
- Is the gain in K.E. equal to loss of P.E.? If not why.

Take $g = 10 \text{ m s}^{-2}$

- 6.39** Two pendulums with identical bobs and lengths are suspended from a common support such that in rest position the two bobs are in contact (Fig. 6.14). One of the bobs is released after being displaced by 10° so that it collides elastically head-on with the other bob.

- Describe the motion of two bobs.
- Draw a graph showing variation in energy of either pendulum with time, for $0 \leq t \leq 2T$, where T is the period of each pendulum.

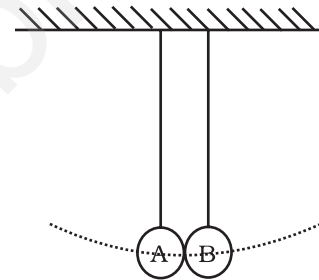

Fig. 6.14

- 6.40** Suppose the average mass of raindrops is $3.0 \times 10^{-5} \text{ kg}$ and their average terminal velocity 9 m s^{-1} . Calculate the energy transferred by rain to each square metre of the surface at a place which receives 100 cm of rain in a year.

- 6.41** An engine is attached to a wagon through a shock absorber of length 1.5 m. The system with a total mass of 50,000 kg is moving with a speed of 36 km h^{-1} when the brakes are applied to bring it to rest. In the process of the system being brought to rest, the spring of the shock absorber gets compressed by 1.0 m. If 90% of energy of the wagon is lost due to friction, calculate the spring constant.

- 6.42** An adult weighing 600 N raises the centre of gravity of his body by 0.25 m while taking each step of 1 m length in jogging. If he jogs for 6 km, calculate the energy utilised by him in jogging assuming that there is no energy loss due to friction of ground and air. Assuming that the body of the adult is capable of converting 10% of energy intake in the form of food, calculate the energy equivalents

of food that would be required to compensate energy utilised for jogging.

- 6.43** On complete combustion a litre of petrol gives off heat equivalent to 3×10^7 J. In a test drive a car weighing 1200 kg, including the mass of driver, runs 15 km per litre while moving with a uniform speed on a straight track. Assuming that friction offered by the road surface and air to be uniform, calculate the force of friction acting on the car during the test drive, if the efficiency of the car engine were 0.5.

LA

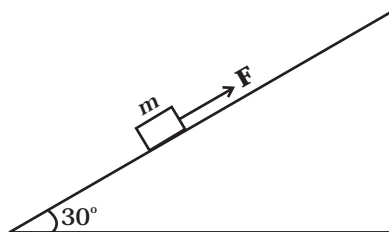

Fig. 6.15

- 6.44** A block of mass 1 kg is pushed up a surface inclined to horizontal at an angle of 30° by a force of 10 N parallel to the inclined surface (Fig. 6.15). The coefficient of friction between block and the incline is 0.1. If the block is pushed up by 10 m along the incline, calculate

- work done against gravity
- work done against force of friction
- increase in potential energy
- increase in kinetic energy
- work done by applied force.

- 6.45** A curved surface is shown in Fig. 6.16. The portion BCD is free of friction. There are three spherical balls of identical radii and masses. Balls are released from rest one by one from A which is at a slightly greater height than C.

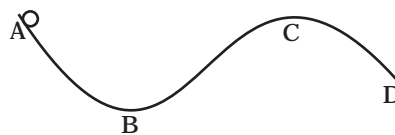

Fig. 6.16

With the surface AB, ball 1 has large enough friction to cause rolling down without slipping; ball 2 has a small friction and ball 3 has a negligible friction.

- For which balls is total mechanical energy conserved?
- Which ball (s) can reach D?
- For balls which do not reach D, which of the balls can reach back A?

- 6.46** A rocket accelerates straight up by ejecting gas downwards. In a small time interval Δt , it ejects a gas of mass Δm at a relative speed u . Calculate KE of the entire system at $t + \Delta t$ and t and show that the device that ejects gas does work = $(\frac{1}{2})\Delta m u^2$ in this time interval (neglect gravity).
- 6.47** Two identical steel cubes (masses 50g, side 1cm) collide head-on face to face with a speed of 10cm/s each. Find the maximum compression of each. Young's modulus for steel = $Y = 2 \times 10^{11} \text{ N/m}^2$.
- 6.48** A balloon filled with helium rises against gravity increasing its potential energy. The speed of the balloon also increases as it rises. How do you reconcile this with the law of conservation of mechanical energy? You can neglect viscous drag of air and assume that density of air is constant.

Chapter Seven

SYSTEM OF PARTICLES AND ROTATIONAL MOTION



MCQ I

- 7.1** For which of the following does the centre of mass lie outside the body ?
- (a) A pencil
 - (b) A shotput
 - (c) A dice
 - (d) A bangle
- 7.2** Which of the following points is the likely position of the centre of mass of the system shown in Fig. 7.1?
- (a) A
 - (b) B
 - (c) C
 - (d) D
- 7.3** A particle of mass m is moving in yz -plane with a uniform velocity v with its trajectory running parallel to $+ve$ y -axis and intersecting

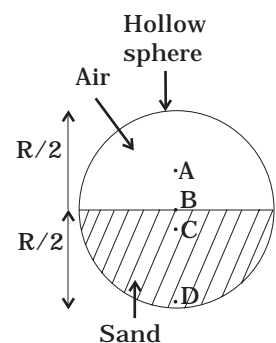

Fig. 7.1

z -axis at $z = a$ (Fig. 7.2). The change in its angular momentum about the origin as it bounces elastically from a wall at $y = \text{constant}$ is:

- (a) $mva \hat{e}_x$
- (b) $2mva \hat{e}_x$
- (c) $ymv \hat{e}_x$
- (d) $2ymv \hat{e}_x$

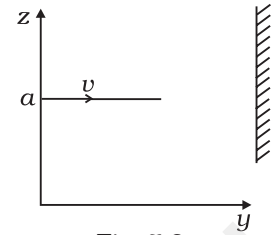

Fig. 7.2

7.4 When a disc rotates with uniform angular velocity, which of the following is not true?

- (a) The sense of rotation remains same.
- (b) The orientation of the axis of rotation remains same.
- (c) The speed of rotation is non-zero and remains same.
- (d) The angular acceleration is non-zero and remains same.

7.5 A uniform square plate has a small piece Q of an irregular shape removed and glued to the centre of the plate leaving a hole behind (Fig. 7.3). The moment of inertia about the z -axis is then

- (a) increased
- (b) decreased
- (c) the same
- (d) changed in unpredicted manner.



Fig. 7.3

7.6 In problem 7.5, the CM of the plate is now in the following quadrant of x - y plane,

- (a) I
- (b) II
- (c) III
- (d) IV

7.7 The density of a non-uniform rod of length 1m is given by $\rho(x) = a(1+bx^2)$

where a and b are constants and $0 \leq x \leq 1$.

The centre of mass of the rod will be at

- (a) $\frac{3(2+b)}{4(3+b)}$
- (b) $\frac{4(2+b)}{3(3+b)}$
- (c) $\frac{3(3+b)}{4(2+b)}$
- (d) $\frac{4(3+b)}{3(2+b)}$

7.8 A Merry-go-round, made of a ring-like platform of radius R and mass M , is revolving with angular speed ω . A person of mass M is standing on it. At one instant, the person jumps off the round, radially away from the centre of the round (as seen from the round). The speed of the round afterwards is

- (a) 2ω (b) ω (c) $\frac{\omega}{2}$ (d) 0

MCQ II

7.9 Choose the correct alternatives:

- (a) For a general rotational motion, angular momentum \mathbf{L} and angular velocity $\boldsymbol{\omega}$ need not be parallel.
 (b) For a rotational motion about a fixed axis, angular momentum \mathbf{L} and angular velocity $\boldsymbol{\omega}$ are always parallel.
 (c) For a general translational motion, momentum \mathbf{p} and velocity \mathbf{v} are always parallel.
 (d) For a general translational motion, acceleration \mathbf{a} and velocity \mathbf{v} are always parallel.

7.10 Figure 7.4 shows two identical particles 1 and 2, each of mass m , moving in opposite directions with same speed v along parallel lines. At a particular instant, \mathbf{r}_1 and \mathbf{r}_2 are their respective position vectors drawn from point A which is in the plane of the parallel lines. Choose the correct options:

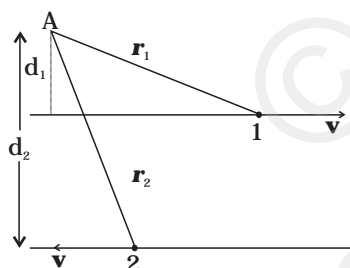

Fig. 7.4

- (a) Angular momentum \mathbf{I}_1 of particle 1 about A is $\mathbf{I}_1 = mvd_1 \odot$
 (b) Angular momentum \mathbf{I}_2 of particle 2 about A is $\mathbf{I}_2 = mvr_2 \odot$
 (c) Total angular momentum of the system about A is $\mathbf{I} = mv(\mathbf{r}_1 + \mathbf{r}_2) \odot$
 (d) Total angular momentum of the system about A is $\mathbf{I} = mv(d_2 - d_1) \otimes$

\odot represents a unit vector coming out of the page.

\otimes represents a unit vector going into the page.

7.11 The net external torque on a system of particles about an axis is zero. Which of the following are compatible with it?

- (a) The forces may be acting radially from a point on the axis.
 (b) The forces may be acting on the axis of rotation.
 (c) The forces may be acting parallel to the axis of rotation.
 (d) The torque caused by some forces may be equal and opposite to that caused by other forces.

7.12 Figure 7.5 shows a lamina in x - y plane. Two axes z and z' pass perpendicular to its plane. A force \mathbf{F} acts in the plane of lamina at point P as shown. Which of the following are true? (The point P is closer to z' -axis than the z -axis.)

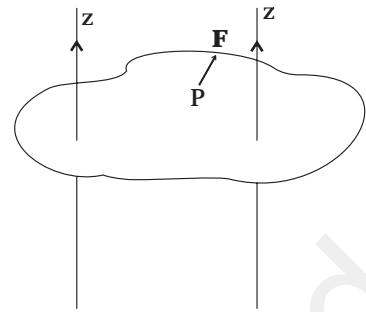

Fig. 7.5

- (a) Torque τ caused by \mathbf{F} about z axis is along $-\hat{\mathbf{k}}$.
- (b) Torque τ' caused by \mathbf{F} about z' axis is along $-\hat{\mathbf{k}}$.
- (c) Torque τ caused by \mathbf{F} about z axis is greater in magnitude than that about z' axis.
- (d) Total torque is given by $\tau = \tau + \tau'$.

7.13 With reference to Fig. 7.6 of a cube of edge a and mass m , state whether the following are true or false. (O is the centre of the cube.)

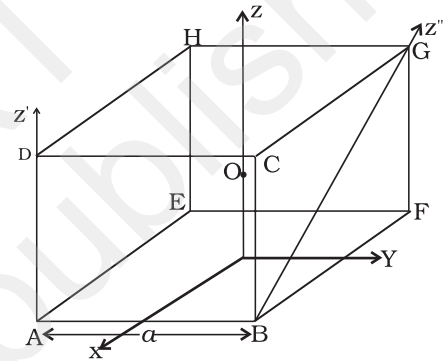

Fig. 7.6

- (a) The moment of inertia of cube about z -axis is $I_z = I_x + I_y$
- (b) The moment of inertia of cube about z' is $I'_z = I_z + \frac{m a^2}{2}$
- (c) The moment of inertia of cube about z'' is $I_{z''} = I_z + \frac{m a^2}{2}$
- (d) $I_x = I_y$

VSA

7.14 The centre of gravity of a body on the earth coincides with its centre of mass for a 'small' object whereas for an 'extended' object it may not. What is the qualitative meaning of 'small' and 'extended' in this regard?

For which of the following the two coincides? A building, a pond, a lake, a mountain?

7.15 Why does a solid sphere have smaller moment of inertia than a hollow cylinder of same mass and radius, about an axis passing through their axes of symmetry?

7.16 The variation of angular position θ , of a point on a rotating rigid body, with time t is shown in Fig. 7.7. Is the body rotating clock-wise or anti-clockwise?

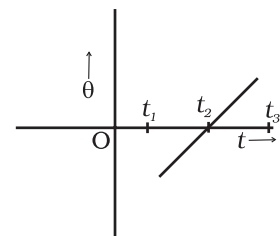

Fig. 7.7

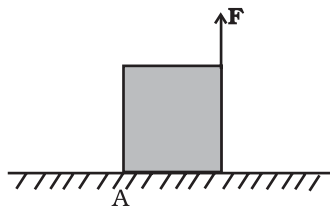

Fig. 7.8

7.17 A uniform cube of mass m and side a is placed on a frictionless horizontal surface. A vertical force F is applied to the edge as shown in Fig. 7.8. Match the following (most appropriate choice):

- | | |
|-----------------------|--|
| (a) $mg/4 < F < mg/2$ | (i) Cube will move up. |
| (b) $F > mg/2$ | (ii) Cube will not exhibit motion. |
| (c) $F > mg$ | (iii) Cube will begin to rotate and slip at A. |
| (d) $F = mg/4$ | (iv) Normal reaction effectively at $a/3$ from A, no motion. |

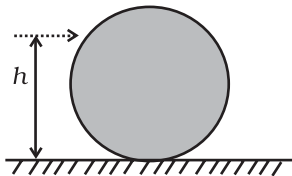

Fig. 7.9

7.18 A uniform sphere of mass m and radius R is placed on a rough horizontal surface (Fig. 7.9). The sphere is struck horizontally at a height h from the floor. Match the following:

- | | |
|----------------|---|
| (a) $h = R/2$ | (i) Sphere rolls without slipping with a constant velocity and no loss of energy. |
| (b) $h = R$ | (ii) Sphere spins clockwise, loses energy by friction. |
| (c) $h = 3R/2$ | (iii) Sphere spins anti-clockwise, loses energy by friction. |
| (d) $h = 7R/5$ | (iv) Sphere has only a translational motion, loses energy by friction. |

SA

7.19 The vector sum of a system of non-collinear forces acting on a rigid body is given to be non-zero. If the vector sum of all the torques due to the system of forces about a certain point is found to be zero, does this mean that it is necessarily zero about any arbitrary point?

7.20 A wheel in uniform motion about an axis passing through its centre and perpendicular to its plane is considered to be in mechanical (translational plus rotational) equilibrium because no net external force or torque is required to sustain its motion. However, the particles that constitute the wheel do experience a centripetal acceleration directed towards the centre. How do you reconcile this fact with the wheel being in equilibrium?

How would you set a half-wheel into uniform motion about an axis passing through the centre of mass of the wheel and perpendicular to its plane? Will you require external forces to sustain the motion?

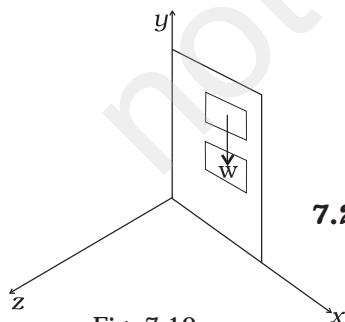

Fig. 7.10

7.21 A door is hinged at one end and is free to rotate about a vertical axis (Fig. 7.10). Does its weight cause any torque about this axis? Give reason for your answer.

7.22 $(n-1)$ equal point masses each of mass m are placed at the vertices of a regular n -polygon. The vacant vertex has a position vector \mathbf{a} with respect to the centre of the polygon. Find the position vector of centre of mass.

LA

7.23 Find the centre of mass of a uniform (a) half-disc, (b) quarter-disc.

7.24 Two discs of moments of inertia I_1 and I_2 about their respective axes (normal to the disc and passing through the centre), and rotating with angular speed ω_1 and ω_2 are brought into contact face to face with their axes of rotation coincident.

- Does the law of conservation of angular momentum apply to the situation? why?
- Find the angular speed of the two-disc system.
- Calculate the loss in kinetic energy of the system in the process.
- Account for this loss.

7.25 A disc of radius R is rotating with an angular speed ω_0 about a horizontal axis. It is placed on a horizontal table. The coefficient of kinetic friction is μ_k .

- What was the velocity of its centre of mass before being brought in contact with the table?
- What happens to the linear velocity of a point on its rim when placed in contact with the table?
- What happens to the linear speed of the centre of mass when disc is placed in contact with the table?
- Which force is responsible for the effects in (b) and (c).
- What condition should be satisfied for rolling to begin?
- Calculate the time taken for the rolling to begin.

7.26 Two cylindrical hollow drums of radii R and $2R$, and of a common height h , are rotating with angular velocities ω (anti-clockwise) and ω (clockwise), respectively. Their axes, fixed are parallel and in a horizontal plane separated by $(3R + \delta)$. They are now brought in contact ($\delta \rightarrow 0$).

- Show the frictional forces just after contact.
- Identify forces and torques external to the system just after contact.
- What would be the ratio of final angular velocities when friction ceases?

7.27 A uniform square plate S (side c) and a uniform rectangular plate R (sides b, a) have identical areas and masses (Fig. 7.11).

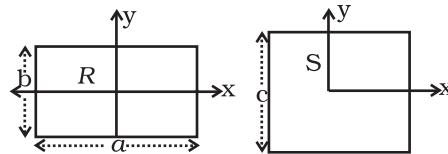

Fig. 7.11

Show that

(i) $I_{xR} / I_{xS} < 1$; (ii) $I_{yR} / I_{yS} > 1$; (iii) $I_{zR} / I_{zS} > 1$.

7.28 A uniform disc of radius R , is resting on a table on its rim. The coefficient of friction between disc and table is μ (Fig 7.12). Now the disc is pulled with a force \mathbf{F} as shown in the figure. What is the maximum value of \mathbf{F} for which the disc rolls without slipping?

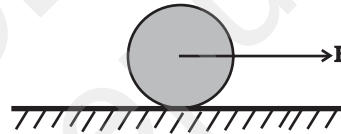

Fig. 7.12

Chapter Eight

GRAVITATION



MCQ I

- 8.1** The earth is an approximate sphere. If the interior contained matter which is not of the same density everywhere, then on the surface of the earth, the acceleration due to gravity
- (a) will be directed towards the centre but not the same everywhere.
 - (b) will have the same value everywhere but not directed towards the centre.
 - (c) will be same everywhere in magnitude directed towards the centre.
 - (d) cannot be zero at any point.
- 8.2** As observed from earth, the sun appears to move in an approximate circular orbit. For the motion of another planet like mercury as observed from earth, this would
- (a) be similarly true.
 - (b) not be true because the force between earth and mercury is not inverse square law.

- (c) not be true because the major gravitational force on mercury is due to sun.
- (d) not be true because mercury is influenced by forces other than gravitational forces.

8.3 Different points in earth are at slightly different distances from the sun and hence experience different forces due to gravitation. For a rigid body, we know that if various forces act at various points in it, the resultant motion is as if a net force acts on the c.m. (centre of mass) causing translation and a net torque at the c.m. causing rotation around an axis through the c.m. For the earth-sun system (approximating the earth as a uniform density sphere)

- (a) the torque is zero.
- (b) the torque causes the earth to spin.
- (c) the rigid body result is not applicable since the earth is not even approximately a rigid body.
- (d) the torque causes the earth to move around the sun.

8.4 Satellites orbiting the earth have finite life and sometimes debris of satellites fall to the earth. This is because,

- (a) the solar cells and batteries in satellites run out.
- (b) the laws of gravitation predict a trajectory spiralling inwards.
- (c) of viscous forces causing the speed of satellite and hence height to gradually decrease.
- (d) of collisions with other satellites.

8.5 Both earth and moon are subject to the gravitational force of the sun. As observed from the sun, the orbit of the moon

- (a) will be elliptical.
- (b) will not be strictly elliptical because the total gravitational force on it is not central.
- (c) is not elliptical but will necessarily be a closed curve.
- (d) deviates considerably from being elliptical due to influence of planets other than earth.

8.6 In our solar system, the inter-planetary region has chunks of matter (much smaller in size compared to planets) called asteroids. They

- (a) will not move around the sun since they have very small masses compared to sun.
- (b) will move in an irregular way because of their small masses and will drift away into outer space.
- (c) will move around the sun in closed orbits but not obey Kepler's laws.
- (d) will move in orbits like planets and obey Kepler's laws.

8.7 Choose the wrong option.

- (a) Inertial mass is a measure of difficulty of accelerating a body by an external force whereas the gravitational mass is relevant in determining the gravitational force on it by an external mass.
- (b) That the gravitational mass and inertial mass are equal is an experimental result.
- (c) That the acceleration due to gravity on earth is the same for all bodies is due to the equality of gravitational mass and inertial mass.
- (d) Gravitational mass of a particle like proton can depend on the presence of neighbouring heavy objects but the inertial mass cannot.

8.8 Particles of masses $2M$, m and M are respectively at points A, B and C with $AB = \frac{1}{2}(BC)$. m is much-much smaller than M and at time $t = 0$, they are all at rest (Fig. 8.1). At subsequent times before any collision takes place:

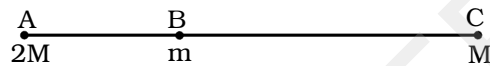

Fig. 8.1

- (a) m will remain at rest.
- (b) m will move towards M .
- (c) m will move towards $2M$.
- (d) m will have oscillatory motion.

MCQ II

8.9 Which of the following options are correct?

- (a) Acceleration due to gravity decreases with increasing altitude.
- (b) Acceleration due to gravity increases with increasing depth (assume the earth to be a sphere of uniform density).
- (c) Acceleration due to gravity increases with increasing latitude.
- (d) Acceleration due to gravity is independent of the mass of the earth.

8.10 If the law of gravitation, instead of being inverse-square law, becomes an inverse-cube law-

- (a) planets will not have elliptic orbits.
- (b) circular orbits of planets is not possible.
- (c) projectile motion of a stone thrown by hand on the surface of the earth will be approximately parabolic.
- (d) there will be no gravitational force inside a spherical shell of uniform density.

- 8.11** If the mass of sun were ten times smaller and gravitational constant G were ten times larger in magnitudes-
- walking on ground would become more difficult.
 - the acceleration due to gravity on earth will not change.
 - raindrops will fall much faster.
 - airplanes will have to travel much faster.
- 8.12** If the sun and the planets carried huge amounts of opposite charges,
- all three of Kepler's laws would still be valid.
 - only the third law will be valid.
 - the second law will not change.
 - the first law will still be valid.
- 8.13** There have been suggestions that the value of the gravitational constant G becomes smaller when considered over very large time period (in billions of years) in the future. If that happens, for our earth,
- nothing will change.
 - we will become hotter after billions of years.
 - we will be going around but not strictly in closed orbits.
 - after sufficiently long time we will leave the solar system.
- 8.14** Supposing Newton's law of gravitation for gravitation forces \mathbf{F}_1 and \mathbf{F}_2 between two masses m_1 and m_2 at positions \mathbf{r}_1 and \mathbf{r}_2 read
- $$\mathbf{F}_1 = -\mathbf{F}_2 = -\frac{\mathbf{r}_{12}}{r_{12}^3} GM_0^2 \left(\frac{m_1 m_2}{M_0^2} \right)^n$$
- where M_0 is a constant of dimension of mass, $\mathbf{r}_{12} = \mathbf{r}_1 - \mathbf{r}_2$ and n is a number. In such a case,
- the acceleration due to gravity on earth will be different for different objects.
 - none of the three laws of Kepler will be valid.
 - only the third law will become invalid.
 - for n negative, an object lighter than water will sink in water.
- 8.15** Which of the following are true?
- A polar satellite goes around the earth's pole in north-south direction.
 - A geostationary satellite goes around the earth in east-west direction.
 - A geostationary satellite goes around the earth in west-east direction.
 - A polar satellite goes around the earth in east-west direction.

- 8.16** The centre of mass of an extended body on the surface of the earth and its centre of gravity
- (a) are always at the same point for any size of the body.
 - (b) are always at the same point only for spherical bodies.
 - (c) can never be at the same point.
 - (d) is close to each other for objects, say of sizes less than 100 m.
 - (e) both can change if the object is taken deep inside the earth.

VSA

- 8.17** Molecules in air in the atmosphere are attracted by gravitational force of the earth. Explain why all of them do not fall into the earth just like an apple falling from a tree.
- 8.18** Give one example each of central force and non-central force.
- 8.19** Draw areal velocity versus time graph for mars.
- 8.20** What is the direction of areal velocity of the earth around the sun?
- 8.21** How is the gravitational force between two point masses affected when they are dipped in water keeping the separation between them the same?
- 8.22** Is it possible for a body to have inertia but no weight?
- 8.23** We can shield a charge from electric fields by putting it inside a hollow conductor. Can we shield a body from the gravitational influence of nearby matter by putting it inside a hollow sphere or by some other means?
- 8.24** An astronaut inside a small spaceship orbiting around the earth cannot detect gravity. If the space station orbiting around the earth has a large size, can he hope to detect gravity?
- 8.25** The gravitational force between a hollow spherical shell (of radius R and uniform density) and a point mass is F . Show the nature of F vs r graph where r is the distance of the point from the centre of the hollow spherical shell of uniform density.
- 8.26** Out of aphelion and perihelion, where is the speed of the earth more and why ?
- 8.27** What is the angle between the equatorial plane and the orbital plane of
- (a) Polar satellite?
 - (b) Geostationary satellite?

SA

8.28 Mean solar day is the time interval between two successive noon when sun passes through zenith point (meridian). Sidereal day is the time interval between two successive transit of a distant star through the zenith point (meridian). By drawing appropriate diagram showing earth's spin and orbital motion, show that mean solar day is four minutes longer than the sidereal day. In other words, distant stars would rise 4 minutes early every successive day.

(Hint: you may assume circular orbit for the earth).

8.29 Two identical heavy spheres are separated by a distance 10 times their radius. Will an object placed at the mid point of the line joining their centres be in stable equilibrium or unstable equilibrium? Give reason for your answer.

8.30 Show the nature of the following graph for a satellite orbiting the earth.

- (a) KE vs orbital radius R
- (b) PE vs orbital radius R
- (c) TE vs orbital radius R .

8.31 Shown are several curves (Fig. 8.2). Explain with reason, which ones amongst them can be possible trajectories traced by a projectile (neglect air friction).

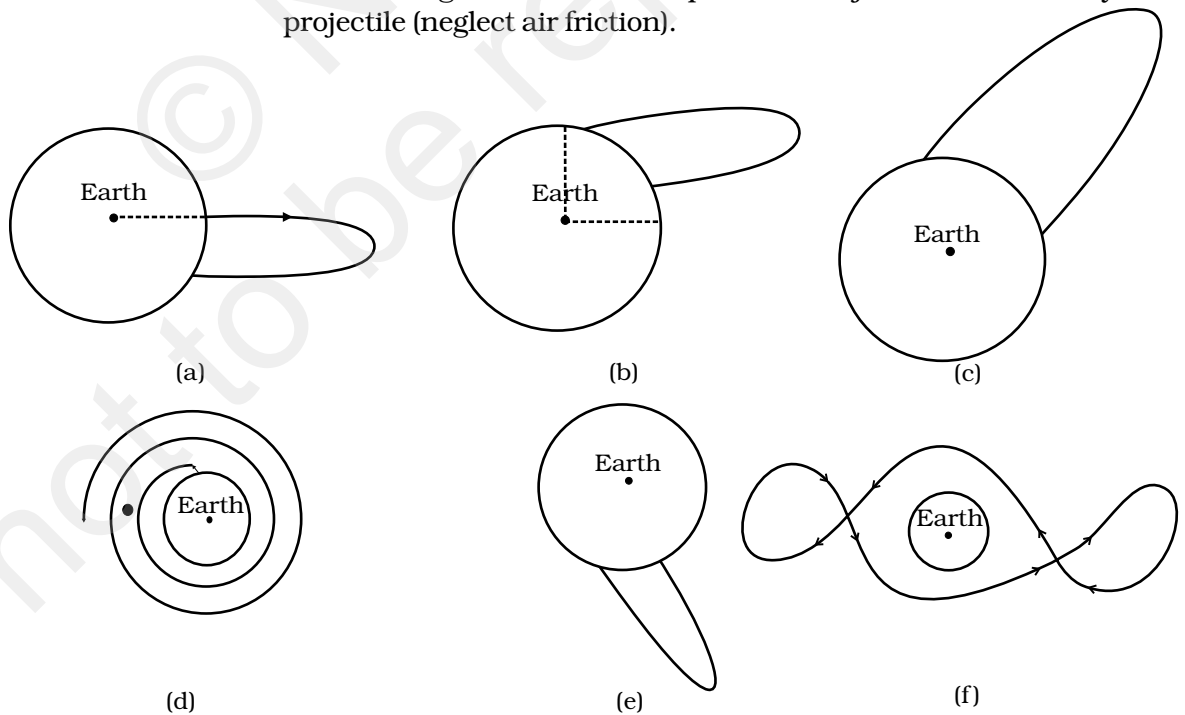

Fig. 8.2

- 8.32** An object of mass m is raised from the surface of the earth to a height equal to the radius of the earth, that is, taken from a distance R to $2R$ from the centre of the earth. What is the gain in its potential energy?
- 8.33** A mass m is placed at P a distance h along the normal through the centre O of a thin circular ring of mass M and radius r (Fig. 8.3).

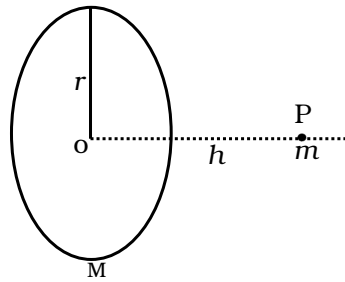

Fig. 8.3

If the mass is removed further away such that OP becomes $2h$, by what factor the force of gravitation will decrease, if $h = r$?

LA

- 8.34** A star like the sun has several bodies moving around it at different distances. Consider that all of them are moving in circular orbits. Let r be the distance of the body from the centre of the star and let its linear velocity be v , angular velocity ω , kinetic energy K , gravitational potential energy U , total energy E and angular momentum l . As the radius r of the orbit increases, determine which of the above quantities increase and which ones decrease.
- 8.35** Six point masses of mass m each are at the vertices of a regular hexagon of side l . Calculate the force on any of the masses.
- 8.36** A satellite is to be placed in equatorial geostationary orbit around earth for communication.
- Calculate height of such a satellite.
 - Find out the minimum number of satellites that are needed to cover entire earth so that at least one satellite is visible from any point on the equator.

[$M = 6 \times 10^{24}$ kg, $R = 6400$ km, $T = 24$ h, $G = 6.67 \times 10^{-11}$ SI units]

8.37 Earth's orbit is an ellipse with eccentricity 0.0167. Thus, earth's distance from the sun and speed as it moves around the sun varies from day to day. This means that the length of the solar day is not constant through the year. Assume that earth's spin axis is normal to its orbital plane and find out the length of the shortest and the longest day. A day should be taken from noon to noon. Does this explain variation of length of the day during the year?

8.38 A satellite is in an elliptic orbit around the earth with aphelion of $6R$ and perihelion of $2R$ where $R = 6400$ km is the radius of the earth. Find eccentricity of the orbit. Find the velocity of the satellite at apogee and perigee. What should be done if this satellite has to be transferred to a circular orbit of radius $6R$?

[$G = 6.67 \times 10^{-11}$ SI units and $M = 6 \times 10^{24}$ kg]

Chapter Nine

MECHANICAL PROPERTIES OF SOLIDS



MCQ I

- 9.1** Modulus of rigidity of ideal liquids is
- (a) infinity.
 - (b) zero.
 - (c) unity.
 - (d) some finite small non-zero constant value.
- 9.2** The maximum load a wire can withstand without breaking, when its length is reduced to half of its original length, will
- (a) be double.
 - (b) be half.
 - (c) be four times.
 - (d) remain same.
- 9.3** The temperature of a wire is doubled. The Young's modulus of elasticity
- (a) will also double.
 - (b) will become four times.

- (c) will remain same.
- (d) will decrease.

9.4 A spring is stretched by applying a load to its free end. The strain produced in the spring is

- (a) volumetric.
- (b) shear.
- (c) longitudinal and shear.
- (d) longitudinal.

9.5 A rigid bar of mass M is supported symmetrically by three wires each of length l . Those at each end are of copper and the middle one is of iron. The ratio of their diameters, if each is to have the same tension, is equal to

(a) $Y_{\text{copper}}/Y_{\text{iron}}$

(b) $\sqrt{\frac{Y_{\text{iron}}}{Y_{\text{copper}}}}$

(c) $\frac{Y_{\text{iron}}^2}{Y_{\text{copper}}^2}$

(d) $\frac{Y_{\text{iron}}}{Y_{\text{copper}}}$

9.6 A mild steel wire of length $2L$ and cross-sectional area A is stretched, well within elastic limit, horizontally between two pillars (Fig. 9.1). A mass m is suspended from the mid point of the wire. Strain in the wire is

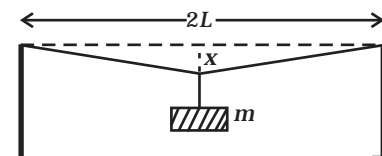

Fig. 9.1

(a) $\frac{x^2}{2L^2}$

(b) $\frac{x}{L}$

(c) $\frac{x^2}{L}$

(d) $\frac{x^2}{2L}$

- 9.7** A rectangular frame is to be suspended symmetrically by two strings of equal length on two supports (Fig. 9.2). It can be done in one of the following three ways;

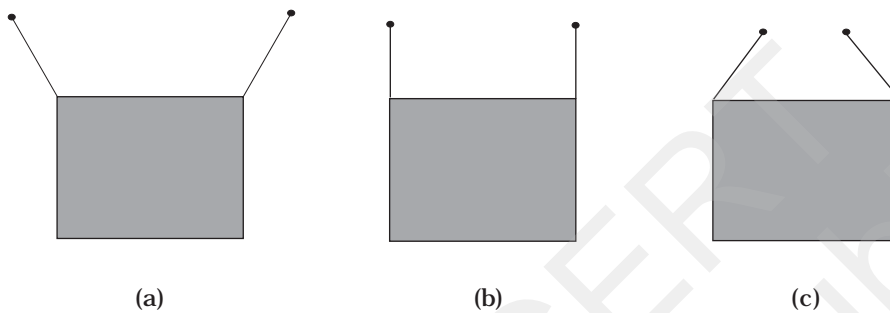

Fig. 9.2

The tension in the strings will be

- (a) the same in all cases.
 (b) least in (a).
 (c) least in (b).
 (d) least in (c).
- 9.8** Consider two cylindrical rods of identical dimensions, one of rubber and the other of steel. Both the rods are fixed rigidly at one end to the roof. A mass M is attached to each of the free ends at the centre of the rods.
- (a) Both the rods will elongate but there shall be no perceptible change in shape.
 (b) The steel rod will elongate and change shape but the rubber rod will only elongate.
 (c) The steel rod will elongate without any perceptible change in shape, but the rubber rod will elongate and the shape of the bottom edge will change to an ellipse.
 (d) The steel rod will elongate, without any perceptible change in shape, but the rubber rod will elongate with the shape of the bottom edge tapered to a tip at the centre.

MCQ II

9.9 The stress-strain graphs for two materials are shown in Fig.9.3 (assume same scale).

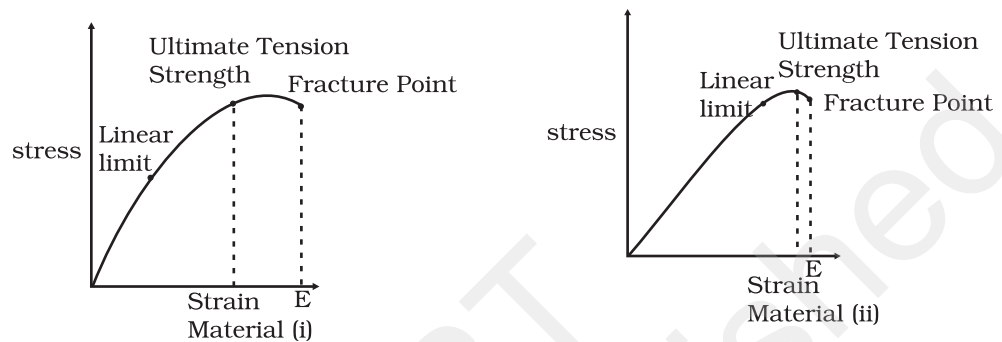

Fig. 9.3

- (a) Material (ii) is more elastic than material (i) and hence material (ii) is more brittle.
 (b) Material (i) and (ii) have the same elasticity and the same brittleness.
 (c) Material (ii) is elastic over a larger region of strain as compared to (i).
 (d) Material (ii) is more brittle than material (i).

9.10 A wire is suspended from the ceiling and stretched under the action of a weight F suspended from its other end. The force exerted by the ceiling on it is equal and opposite to the weight.

- (a) Tensile stress at any cross section A of the wire is F/A .
 (b) Tensile stress at any cross section is zero.
 (c) Tensile stress at any cross section A of the wire is $2F/A$.
 (d) Tension at any cross section A of the wire is F .

9.11 A rod of length l and negligible mass is suspended at its two ends by two wires of steel (wire A) and aluminium (wire B) of equal lengths (Fig. 9.4). The cross-sectional areas of wires A and B are 1.0 mm^2 and 2.0 mm^2 , respectively.

$$(Y_{Al} = 70 \times 10^9 \text{ Nm}^{-2} \text{ and } Y_{steel} = 200 \times 10^9 \text{ Nm}^{-2})$$

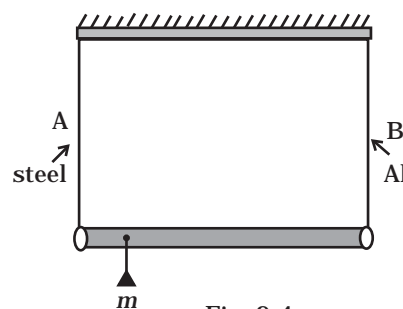

Fig. 9.4

- (a) Mass m should be suspended close to wire A to have equal stresses in both the wires.
- (b) Mass m should be suspended close to B to have equal stresses in both the wires.
- (c) Mass m should be suspended at the middle of the wires to have equal stresses in both the wires.
- (d) Mass m should be suspended close to wire A to have equal strain in both wires.

9.12 For an ideal liquid

- (a) the bulk modulus is infinite.
- (b) the bulk modulus is zero.
- (c) the shear modulus is infinite.
- (d) the shear modulus is zero.

9.13 A copper and a steel wire of the same diameter are connected end to end. A deforming force F is applied to this composite wire which causes a total elongation of 1 cm. The two wires will have

- (a) the same stress.
- (b) different stress.
- (c) the same strain.
- (d) different strain.

VSA

- 9.14** The Young's modulus for steel is much more than that for rubber. For the same longitudinal strain, which one will have greater tensile stress?
- 9.15** Is stress a vector quantity?
- 9.16** Identical springs of steel and copper are equally stretched. On which, more work will have to be done?
- 9.17** What is the Young's modulus for a perfect rigid body?
- 9.18** What is the Bulk modulus for a perfect rigid body?

SA

- 9.19** A wire of length L and radius r is clamped rigidly at one end. When the other end of the wire is pulled by a force f , its length increases by l . Another wire of the same material of length $2L$ and radius $2r$, is pulled by a force $2f$. Find the increase in length of this wire.

- 9.20** A steel rod ($Y = 2.0 \times 10^{11} \text{ Nm}^{-2}$; and $\alpha = 10^{-50} \text{ C}^{-1}$) of length 1 m and area of cross-section 1 cm^2 is heated from 0°C to 200°C , without being allowed to extend or bend. What is the tension produced in the rod?
- 9.21** To what depth must a rubber ball be taken in deep sea so that its volume is decreased by 0.1%. (The bulk modulus of rubber is $9.8 \times 10^8 \text{ N m}^{-2}$; and the density of sea water is 10^3 kg m^{-3} .)
- 9.22** A truck is pulling a car out of a ditch by means of a steel cable that is 9.1 m long and has a radius of 5 mm. When the car just begins to move, the tension in the cable is 800 N. How much has the cable stretched? (Young's modulus for steel is $2 \times 10^{11} \text{ Nm}^{-2}$.)
- 9.23** Two identical solid balls, one of ivory and the other of wet-clay, are dropped from the same height on the floor. Which one will rise to a greater height after striking the floor and why?

LA

- 9.24** Consider a long steel bar under a tensile stress due to forces F acting at the edges along the length of the bar (Fig. 9.5). Consider a plane making an angle θ with the length. What are the tensile and shearing stresses on this plane?

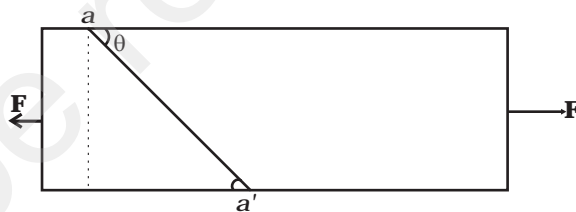

Fig. 9.5

- (a) For what angle is the tensile stress a maximum?
 (b) For what angle is the shearing stress a maximum?
- 9.25** (a) A steel wire of mass μ per unit length with a circular cross section has a radius of 0.1 cm. The wire is of length 10 m when measured lying horizontal, and hangs from a hook on the wall. A mass of 25 kg is hung from the free end of the wire. Assuming the wire to be uniform and lateral strains \ll longitudinal strains, find the extension in the length of the wire. The density of steel is 7860 kg m^{-3} (Young's modulus $Y = 2 \times 10^{11} \text{ Nm}^{-2}$).
- (b) If the yield strength of steel is $2.5 \times 10^8 \text{ Nm}^{-2}$, what is the maximum weight that can be hung at the lower end of the wire?

- 9.26** A steel rod of length $2l$, cross sectional area A and mass M is set rotating in a horizontal plane about an axis passing through the centre. If Y is the Young's modulus for steel, find the extension in the length of the rod. (Assume the rod is uniform.)
- 9.27** An equilateral triangle ABC is formed by two Cu rods AB and BC and one Al rod. It is heated in such a way that temperature of each rod increases by ΔT . Find change in the angle ABC. [Coeff. of linear expansion for Cu is α_1 , Coeff. of linear expansion for Al is α_2]
- 9.28** In nature, the failure of structural members usually result from large torque because of twisting or bending rather than due to tensile or compressive strains. This process of structural breakdown is called buckling and in cases of tall cylindrical structures like trees, the torque is caused by its own weight bending the structure. Thus the vertical through the centre of gravity does not fall within the base. The elastic torque caused because of this bending about the central axis of the tree is given by $\frac{Y\pi r^4}{4R}$. Y is the Young's modulus, r is the radius of the trunk and R is the radius of curvature of the bent surface along the height of the tree containing the centre of gravity (the neutral surface). Estimate the critical height of a tree for a given radius of the trunk.
- 9.29** A stone of mass m is tied to an elastic string of negligible mass and spring constant k . The unstretched length of the string is L and has negligible mass. The other end of the string is fixed to a nail at a point P . Initially the stone is at the same level as the point P . The stone is dropped vertically from point P .
- Find the distance y from the top when the mass comes to rest for an instant, for the first time.
 - What is the maximum velocity attained by the stone in this drop?
 - What shall be the nature of the motion after the stone has reached its lowest point?

Chapter Ten

MECHANICAL PROPERTIES OF FLUIDS



MCQ I

10.1 A tall cylinder is filled with viscous oil. A round pebble is dropped from the top with zero initial velocity. From the plot shown in Fig. 10.1, indicate the one that represents the velocity (v) of the pebble as a function of time (t).

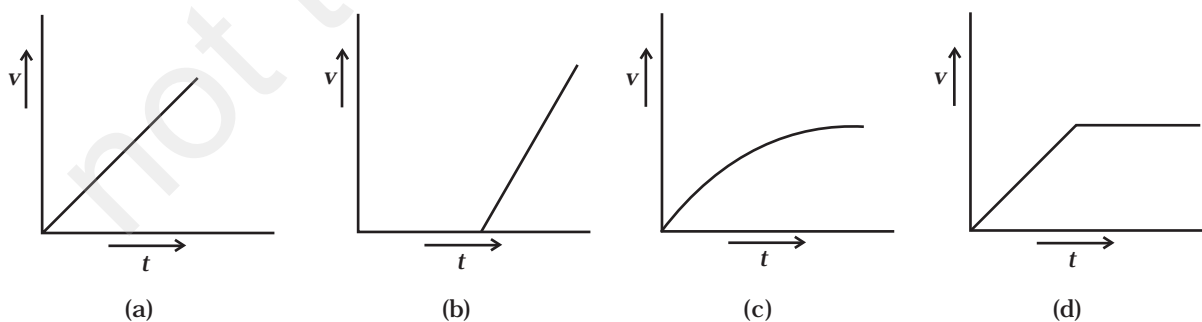

Fig. 10.1

10.2 Which of the following diagrams (Fig. 10.2) does not represent a streamline flow?

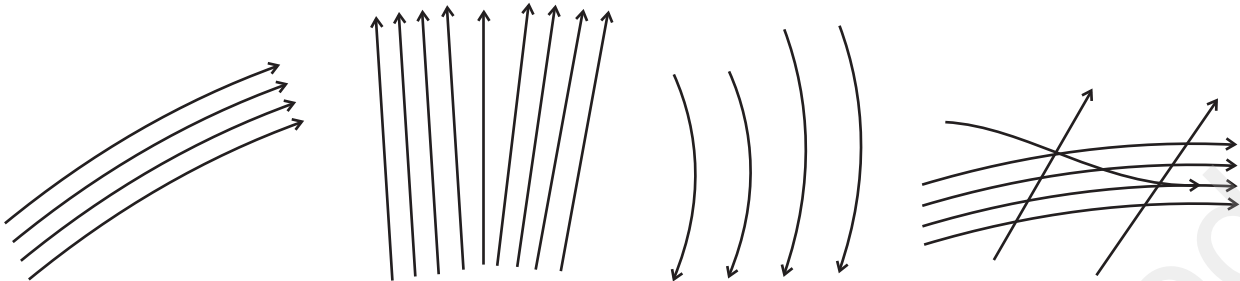

Fig. 10.2

10.3 Along a streamline

- (a) the velocity of a fluid particle remains constant.
- (b) the velocity of all fluid particles crossing a given position is constant.
- (c) the velocity of all fluid particles at a given instant is constant.
- (d) the speed of a fluid particle remains constant.

10.4 An ideal fluid flows through a pipe of circular cross-section made of two sections with diameters 2.5 cm and 3.75 cm. The ratio of the velocities in the two pipes is

- (a) 9:4
- (b) 3:2
- (c) $\sqrt{3} : \sqrt{2}$
- (d) $\sqrt{2} : \sqrt{3}$

10.5 The angle of contact at the interface of water-glass is 0° , Ethylalcohol-glass is 0° , Mercury-glass is 140° and Methyl iodide-glass is 30° . A glass capillary is put in a trough containing one of these four liquids. It is observed that the meniscus is convex. The liquid in the trough is

- (a) water
- (b) ethylalcohol
- (c) mercury
- (d) methyl iodide.

MCQ II

10.6 For a surface molecule

- (a) the net force on it is zero.
- (b) there is a net downward force.

- (c) the potential energy is less than that of a molecule inside.
- (d) the potential energy is more than that of a molecule inside.

10.7 Pressure is a scalar quantity because

- (a) it is the ratio of force to area and both force and area are vectors.
- (b) it is the ratio of the magnitude of the force to area.
- (c) it is the ratio of the component of the force normal to the area.
- (d) it does not depend on the size of the area chosen.

10.8 A wooden block with a coin placed on its top, floats in water as shown in Fig. 10.3.

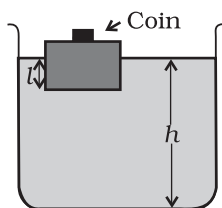

Fig. 10.3

The distance l and h are shown in the figure. After some time the coin falls into the water. Then

- (a) l decreases.
- (b) h decreases.
- (c) l increases.
- (d) h increase.

10.9 With increase in temperature, the viscosity of

- (a) gases decreases.
- (b) liquids increases.
- (c) gases increases.
- (d) liquids decreases.

10.10 Streamline flow is more likely for liquids with

- (a) high density.
- (b) high viscosity.
- (c) low density.
- (d) low viscosity.

VSA

10.11 Is viscosity a vector?

10.12 Is surface tension a vector?

10.13 Iceberg floats in water with part of it submerged. What is the fraction of the volume of iceberg submerged if the density of ice is $\rho_i = 0.917 \text{ g cm}^{-3}$?

10.14 A vessel filled with water is kept on a weighing pan and the scale adjusted to zero. A block of mass M and density ρ is suspended by a massless spring of spring constant k . This block is submerged inside into the water in the vessel. What is the reading of the scale?

10.15 A cubical block of density ρ is floating on the surface of water. Out of its height L , fraction x is submerged in water. The vessel is in an elevator accelerating upward with acceleration a . What is the fraction immersed?

SA

10.16 The sap in trees, which consists mainly of water in summer, rises in a system of capillaries of radius $r = 2.5 \times 10^{-5}$ m. The surface tension of sap is $T = 7.28 \times 10^{-2}$ N m⁻¹ and the angle of contact is 0° . Does surface tension alone account for the supply of water to the top of all trees?

10.17 The free surface of oil in a tanker, at rest, is horizontal. If the tanker starts accelerating the free surface will be titled by an angle θ . If the acceleration is a m s⁻², what will be the slope of the free surface?

10.18 Two mercury droplets of radii 0.1 cm. and 0.2 cm. collapse into one single drop. What amount of energy is released? The surface tension of mercury $T = 435.5 \times 10^{-3}$ N m⁻¹.

10.19 If a drop of liquid breaks into smaller droplets, it results in lowering of temperature of the droplets. Let a drop of radius R , break into N small droplets each of radius r . Estimate the drop in temperature.

10.20 The surface tension and vapour pressure of water at 20°C is 7.28×10^{-2} N m⁻¹ and 2.33×10^3 Pa, respectively. What is the radius of the smallest spherical water droplet which can form without evaporating at 20°C ?

LA

10.21 (a) Pressure decreases as one ascends the atmosphere. If the density of air is ρ , what is the change in pressure dp over a differential height dh ?

(b) Considering the pressure p to be proportional to the density, find the pressure p at a height h if the pressure on the surface of the earth is p_0 .

(c) If $p_0 = 1.03 \times 10^5$ N m⁻², $\rho_0 = 1.29$ kg m⁻³ and $g = 9.8$ m s⁻², at what height will the pressure drop to $(1/10)$ the value at the surface of the earth?

(d) This model of the atmosphere works for relatively small distances. Identify the underlying assumption that limits the model.

10.22 Surface tension is exhibited by liquids due to force of attraction between molecules of the liquid. The surface tension decreases

with increase in temperature and vanishes at boiling point. Given that the latent heat of vaporisation for water $L_v = 540 \text{ k cal kg}^{-1}$, the mechanical equivalent of heat $J = 4.2 \text{ J cal}^{-1}$, density of water $\rho_w = 10^3 \text{ kg l}^{-1}$, Avagadro's No $N_A = 6.0 \times 10^{26} \text{ k mole}^{-1}$ and the molecular weight of water $M_A = 18 \text{ kg for 1 k mole}$.

(a) estimate the energy required for one molecule of water to evaporate.

(b) show that the inter-molecular distance for water is

$$d = \left[\frac{M_A}{N_A} \times \frac{1}{\rho_w} \right]^{1/3} \text{ and find its value.}$$

(c) 1 g of water in the vapor state at 1 atm occupies 1601 cm^3 . Estimate the intermolecular distance at boiling point, in the vapour state.

(d) During vaporisation a molecule overcomes a force F , assumed constant, to go from an inter-molecular distance d to d' . Estimate the value of F .

(e) Calculate F/d , which is a measure of the surface tension.

10.23 A hot air balloon is a sphere of radius 8 m. The air inside is at a temperature of 60°C . How large a mass can the balloon lift when the outside temperature is 20°C ? (Assume air is an ideal gas, $R = 8.314 \text{ J mole}^{-1}\text{K}^{-1}$, $1 \text{ atm.} = 1.013 \times 10^5 \text{ Pa}$; the membrane tension is 5 N m^{-1} .)

Chapter Eleven

THERMAL PROPERTIES OF MATTER



MCQ I

- 11.1** A bimetallic strip is made of aluminium and steel ($\alpha_{Al} > \alpha_{steel}$). On heating, the strip will
- (a) remain straight.
 - (b) get twisted.
 - (c) will bend with aluminium on concave side.
 - (d) will bend with steel on concave side.
- 11.2** A uniform metallic rod rotates about its perpendicular bisector with constant angular speed. If it is heated uniformly to raise its temperature slightly
- (a) its speed of rotation increases.
 - (b) its speed of rotation decreases.
 - (c) its speed of rotation remains same.
 - (d) its speed increases because its moment of inertia increases.
- 11.3** The graph between two temperature scales A and B is shown in Fig. 11.1. Between upper fixed point and lower fixed point there

are 150 equal division on scale A and 100 on scale B.
The relationship for conversion between the two scales is given by

$$(a) \frac{t_A - 180}{100} = \frac{t_B}{150}$$

$$(b) \frac{t_A - 30}{150} = \frac{t_B}{100}$$

$$(c) \frac{t_B - 180}{150} = \frac{t_A}{100}$$

$$(d) \frac{t_B - 40}{100} = \frac{t_A}{180}$$

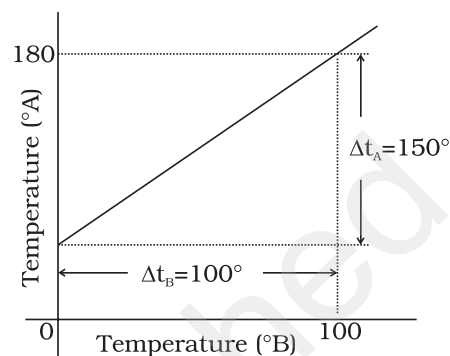

Fig. 11.1

11.4 An aluminium sphere is dipped into water. Which of the following is true?

- (a) Buoyancy will be less in water at 0°C than that in water at 4°C.
- (b) Buoyancy will be more in water at 0°C than that in water at 4°C.
- (c) Buoyancy in water at 0°C will be same as that in water at 4°C.
- (d) Buoyancy may be more or less in water at 4°C depending on the radius of the sphere.

11.5 As the temperature is increased, the time period of a pendulum

- (a) increases as its effective length increases even though its centre of mass still remains at the centre of the bob.
- (b) decreases as its effective length increases even though its centre of mass still remains at the centre of the bob.
- (c) increases as its effective length increases due to shifting of centre of mass below the centre of the bob.
- (d) decreases as its effective length remains same but the centre of mass shifts above the centre of the bob.

11.6 Heat is associated with

- (a) kinetic energy of random motion of molecules.
- (b) kinetic energy of orderly motion of molecules.
- (c) total kinetic energy of random and orderly motion of molecules.
- (d) kinetic energy of random motion in some cases and kinetic energy of orderly motion in other.

- 11.7** The radius of a metal sphere at room temperature T is R , and the coefficient of linear expansion of the metal is α . The sphere is heated a little by a temperature ΔT so that its new temperature is $T + \Delta T$. The increase in the volume of the sphere is approximately
- (a) $2\pi R \alpha \Delta T$
 - (b) $\pi R^2 \alpha \Delta T$
 - (c) $4\pi R^3 \alpha \Delta T / 3$
 - (d) $4\pi R^3 \alpha \Delta T$
- 11.8** A sphere, a cube and a thin circular plate, all of same material and same mass are initially heated to same high temperature.
- (a) Plate will cool fastest and cube the slowest
 - (b) Sphere will cool fastest and cube the slowest
 - (c) Plate will cool fastest and sphere the slowest
 - (d) Cube will cool fastest and plate the slowest.

MCQ II

- 11.9** Mark the correct options:
- (a) A system X is in thermal equilibrium with Y but not with Z . System Y and Z may be in thermal equilibrium with each other.
 - (b) A system X is in thermal equilibrium with Y but not with Z . Systems Y and Z are not in thermal equilibrium with each other.
 - (c) A system X is neither in thermal equilibrium with Y nor with Z . The systems Y and Z must be in thermal equilibrium with each other.
 - (d) A system X is neither in thermal equilibrium with Y nor with Z . The system Y and Z may be in thermal equilibrium with each other.
- 11.10** 'Gulab Jamuns' (assumed to be spherical) are to be heated in an oven. They are available in two sizes, one twice bigger (in radius) than the other. Pizzas (assumed to be discs) are also to be heated in oven. They are also in two sizes, one twice big (in radius) than the other. All four are put together to be heated to oven temperature. Choose the correct option from the following:
- (a) Both size gulab jamuns will get heated in the same time.
 - (b) Smaller gulab jamuns are heated before bigger ones.
 - (c) Smaller pizzas are heated before bigger ones.
 - (d) Bigger pizzas are heated before smaller ones.

11.11 Refer to the plot of temperature versus time (Fig. 11.2) showing the changes in the state of ice on heating (not to scale).

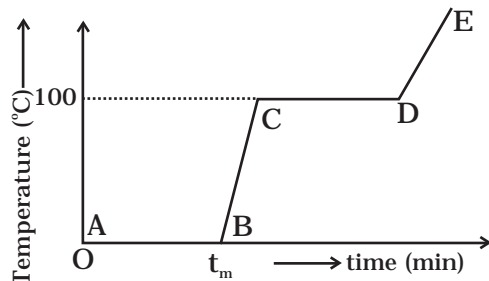

Fig. 11.2

Which of the following is correct?

- (a) The region AB represents ice and water in thermal equilibrium.
- (b) At B water starts boiling.
- (c) At C all the water gets converted into steam.
- (d) C to D represents water and steam in equilibrium at boiling point.

11.12 A glass full of hot milk is poured on the table. It begins to cool gradually. Which of the following is correct?

- (a) The rate of cooling is constant till milk attains the temperature of the surrounding.
- (b) The temperature of milk falls off exponentially with time.
- (c) While cooling, there is a flow of heat from milk to the surrounding as well as from surrounding to the milk but the net flow of heat is from milk to the surrounding and that is why it cools.
- (d) All three phenomenon, conduction, convection and radiation are responsible for the loss of heat from milk to the surroundings.

VSA

11.13 Is the bulb of a thermometer made of diathermic or adiabatic wall?

11.14 A student records the initial length l , change in temperature ΔT and change in length Δl of a rod as follows:

S.No.	l (m)	ΔT ($^{\circ}\text{C}$)	Δl (m)
1.	2	10	4×10^{-4}
2.	1	10	4×10^{-4}
3.	2	20	2×10^{-4}
4.	3	10	6×10^{-4}

If the first observation is correct, what can you say about observations 2, 3 and 4.

- 11.15** Why does a metal bar appear hotter than a wooden bar at the same temperature? Equivalently it also appears cooler than wooden bar if they are both colder than room temperature.
- 11.16** Calculate the temperature which has same numeral value on celsius and Fahrenheit scale.
- 11.17** These days people use steel utensils with copper bottom. This is supposed to be good for uniform heating of food. Explain this effect using the fact that copper is the better conductor.

SA

- 11.18** Find out the increase in moment of inertia I of a uniform rod (coefficient of linear expansion α) about its perpendicular bisector when its temperature is slightly increased by ΔT .
- 11.19** During summers in India, one of the common practice to keep cool is to make ice balls of crushed ice, dip it in flavoured sugar syrup and sip it. For this a stick is inserted into crushed ice and is squeezed in the palm to make it into the ball. Equivalently in winter, in those areas where it snows, people make snow balls and throw around. Explain the formation of ball out of crushed ice or snow in the light of P - T diagram of water.
- 11.20** 100 g of water is supercooled to -10°C . At this point, due to some disturbance mechanised or otherwise some of it suddenly freezes to ice. What will be the temperature of the resultant mixture and how much mass would freeze?

$$[S_w = 1\text{cal/g}^\circ\text{C and } L_{\text{Fusion}}^w = 80\text{cal/g}]$$

- 11.21** One day in the morning, Ramesh filled up $1/3$ bucket of hot water from geyser, to take bath. Remaining $2/3$ was to be filled by cold water (at room temperature) to bring mixture to a comfortable temperature. Suddenly Ramesh had to attend to something which would take some times, say 5-10 minutes before he could take bath. Now he had two options: (i) fill the remaining bucket completely by cold water and then attend to the work, (ii) first attend to the work and fill the remaining bucket just before taking bath. Which option do you think would have kept water warmer? Explain.

LA

11.22 We would like to prepare a scale whose length does not change with temperature. It is proposed to prepare a unit scale of this type whose length remains, say 10 cm. We can use a bimetallic strip made of brass and iron each of different length whose length (both components) would change in such a way that difference between their lengths remain constant. If $\alpha_{iron} = 1.2 \times 10^{-5} / K$ and $\alpha_{brass} = 1.8 \times 10^{-5} / K$, what should we take as length of each strip?

11.23 We would like to make a vessel whose volume does not change with temperature (take a hint from the problem above). We can use brass and iron ($\beta_{vbrass} = 6 \times 10^{-5} / K$ and $\beta_{viron} = 3.55 \times 10^{-5} / K$) to create a volume of 100 cc. How do you think you can achieve this.

11.24 Calculate the stress developed inside a tooth cavity filled with copper when hot tea at temperature of $57^\circ C$ is drunk. You can take body (tooth) temperature to be $37^\circ C$ and $\alpha = 1.7 \times 10^{-5} / ^\circ C$, bulk modulus for copper = $140 \times 10^9 N/m^2$.

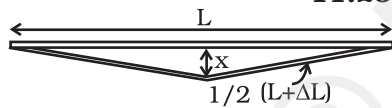

Fig. 11.3

11.25 A rail track made of steel having length 10 m is clamped on a railway line at its two ends (Fig 11.3). On a summer day due to rise in temperature by $20^\circ C$, it is deformed as shown in figure. Find x (displacement of the centre) if $\alpha_{steel} = 1.2 \times 10^{-5} / ^\circ C$.

11.26 A thin rod having length L_0 at $0^\circ C$ and coefficient of linear expansion α has its two ends maintained at temperatures θ_1 and θ_2 , respectively. Find its new length.

11.27 According to Stefan’s law of radiation, a black body radiates energy σT^4 from its unit surface area every second where T is the surface temperature of the black body and $\sigma = 5.67 \times 10^{-8} W / m^2 K^4$ is known as Stefan’s constant. A nuclear weapon may be thought of as a ball of radius 0.5 m. When detonated, it reaches temperature of $10^6 K$ and can be treated as a black body.

- (a) Estimate the power it radiates.
- (b) If surrounding has water at $30^\circ C$, how much water can 10% of the energy produced evaporate in 1 s?

$$[S_w = 4186.0 J / kg K \text{ and } L_v = 22.6 \times 10^5 J / kg]$$

- (c) If all this energy U is in the form of radiation, corresponding momentum is $p = U/c$. How much momentum per unit time does it impart on unit area at a distance of 1 km?

Chapter Twelve

THERMODYNAMICS



MCQ I

12.1 An ideal gas undergoes four different processes from the same initial state (Fig. 12.1). Four processes are adiabatic, isothermal, isobaric and isochoric. Out of 1, 2, 3 and 4 which one is adiabatic.

- (a) 4
- (b) 3
- (c) 2
- (d) 1

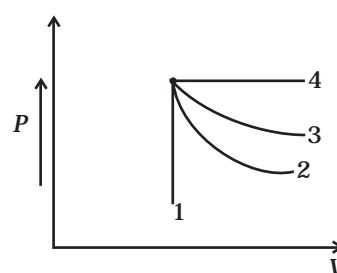

Fig. 12.1

12.2 If an average person jogs, hse produces 14.5×10^3 cal/min. This is removed by the evaporation of sweat. The amount of sweat evaporated per minute (assuming 1 kg requires 580×10^3 cal for evaporation) is

- (a) 0.25 kg
- (b) 2.25 kg
- (c) 0.05 kg
- (d) 0.20 kg

12.3 Consider P - V diagram for an ideal gas shown in Fig 12.2.

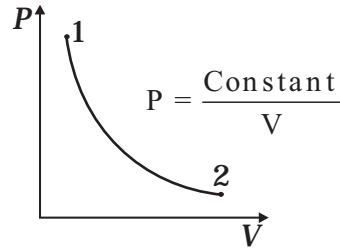

Fig. 12.2

Out of the following diagrams (Fig. 12.3), which represents the T - P diagram?

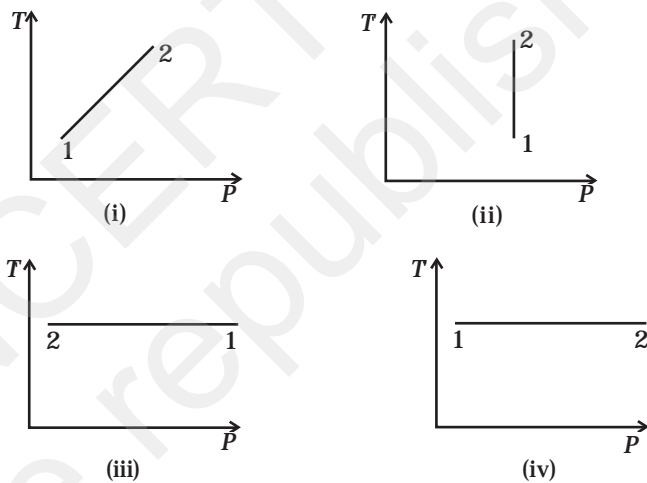

Fig. 12.3

- (a) (iv)
- (b) (ii)
- (c) (iii)
- (d) (i)

12.4 An ideal gas undergoes cyclic process ABCDA as shown in given P - V diagram (Fig. 12.4).

The amount of work done by the gas is

- (a) $6P_0V_0$
- (b) $-2P_0V_0$
- (c) $+2P_0V_0$
- (d) $+4P_0V_0$

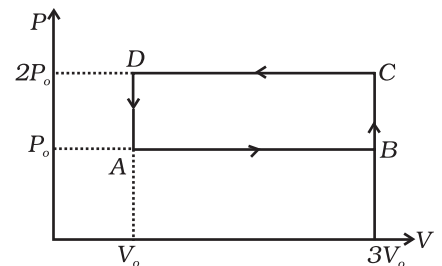

Fig 12.4

12.5 Consider two containers A and B containing identical gases at the same pressure, volume and temperature. The gas in container A is compressed to half of its original volume isothermally while the gas in container B is compressed to half of its original value adiabatically. The ratio of final pressure of gas in B to that of gas in A is

- (a) $2^{\gamma-1}$
 (b) $\left(\frac{1}{2}\right)^{\gamma-1}$
 (c) $\left(\frac{1}{1-\gamma}\right)^2$
 (d) $\left(\frac{1}{\gamma-1}\right)^2$

12.6 Three copper blocks of masses M_1 , M_2 and M_3 kg respectively are brought into thermal contact till they reach equilibrium. Before contact, they were at T_1 , T_2 , T_3 ($T_1 > T_2 > T_3$). Assuming there is no heat loss to the surroundings, the equilibrium temperature T is (s is specific heat of copper)

- (a) $T = \frac{T_1 + T_2 + T_3}{3}$
 (b) $T = \frac{M_1 T_1 + M_2 T_2 + M_3 T_3}{M_1 + M_2 + M_3}$
 (c) $T = \frac{M_1 T_1 + M_2 T_2 + M_3 T_3}{3(M_1 + M_2 + M_3)}$
 (d) $T = \frac{M_1 T_1 s + M_2 T_2 s + M_3 T_3 s}{M_1 + M_2 + M_3}$

MCQ II

12.7 Which of the processes described below are irreversible?

- (a) The increase in temperature of an iron rod by hammering it.
 (b) A gas in a small container at a temperature T_1 is brought in contact with a big reservoir at a higher temperature T_2 which increases the temperature of the gas.
 (c) A quasi-static isothermal expansion of an ideal gas in cylinder fitted with a frictionless piston.

(d) An ideal gas is enclosed in a piston cylinder arrangement with adiabatic walls. A weight W is added to the piston, resulting in compression of gas.

12.8 An ideal gas undergoes isothermal process from some initial state i to final state f . Choose the correct alternatives.

- (a) $dU = 0$
- (b) $dQ = 0$
- (c) $dQ = dU$
- (d) $dQ = dW$

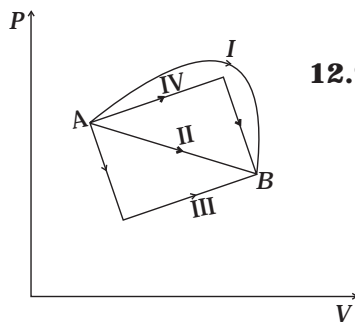

Fig. 12.5

12.9 Figure 12.5 shows the P - V diagram of an ideal gas undergoing a change of state from A to B . Four different parts I, II, III and IV as shown in the figure may lead to the same change of state.

- (a) Change in internal energy is same in IV and III cases, but not in I and II.
- (b) Change in internal energy is same in all the four cases.
- (c) Work done is maximum in case I
- (d) Work done is minimum in case II.

12.10 Consider a cycle followed by an engine (Fig. 12.6)

- 1 to 2 is isothermal
- 2 to 3 is adiabatic
- 3 to 1 is adiabatic

Such a process does not exist because

- (a) heat is completely converted to mechanical energy in such a process, which is not possible.
- (b) mechanical energy is completely converted to heat in this process, which is not possible.
- (c) curves representing two adiabatic processes don't intersect.
- (d) curves representing an adiabatic process and an isothermal process don't intersect.

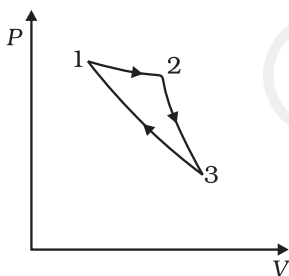

Fig. 12.6

12.11 Consider a heat engine as shown in Fig. 12.7. Q_1 and Q_2 are heat added to heat bath T_1 and heat taken from T_2 in one cycle of engine. W is the mechanical work done on the engine.

If $W > 0$, then possibilities are:

- (a) $Q_1 > Q_2 > 0$
- (b) $Q_2 > Q_1 > 0$
- (c) $Q_2 < Q_1 < 0$
- (d) $Q_1 < 0, Q_2 > 0$

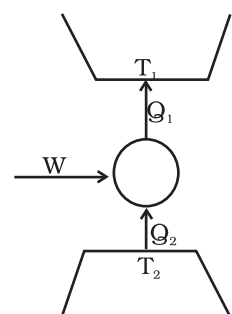

Fig. 12.7

VSA

- 12.12** Can a system be heated and its temperature remains constant?
- 12.13** A system goes from P to Q by two different paths in the P - V diagram as shown in Fig. 12.8. Heat given to the system in path 1 is 1000 J. The work done by the system along path 1 is more than path 2 by 100 J. What is the heat exchanged by the system in path 2?
- 12.14** If a refrigerator's door is kept open, will the room become cool or hot? Explain.
- 12.15** Is it possible to increase the temperature of a gas without adding heat to it? Explain.
- 12.16** Air pressure in a car tyre increases during driving. Explain.

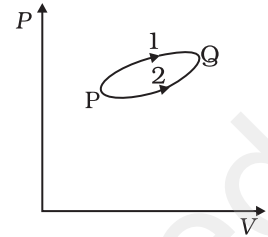

Fig. 12.8

SA

- 12.17** Consider a Carnot's cycle operating between $T_1 = 500\text{K}$ and $T_2 = 300\text{K}$ producing 1 k J of mechanical work per cycle. Find the heat transferred to the engine by the reservoirs.
- 12.18** A person of mass 60 kg wants to lose 5kg by going up and down a 10m high stairs. Assume he burns twice as much fat while going up than coming down. If 1 kg of fat is burnt on expending 7000 kilo calories, how many times must he go up and down to reduce his weight by 5 kg?
- 12.19** Consider a cycle tyre being filled with air by a pump. Let V be the volume of the tyre (fixed) and at each stroke of the pump $\Delta V (\ll V)$ of air is transferred to the tube adiabatically. What is the work done when the pressure in the tube is increased from P_1 to P_2 ?
- 12.20** In a refrigerator one removes heat from a lower temperature and deposits to the surroundings at a higher temperature. In this process, mechanical work has to be done, which is provided by an electric motor. If the motor is of 1kW power, and heat is transferred from -3°C to 27°C , find the heat taken out of the refrigerator per second assuming its efficiency is 50% of a perfect engine.

12.21 If the co-efficient of performance of a refrigerator is 5 and operates at the room temperature (27 °C), find the temperature inside the refrigerator.

12.22 The initial state of a certain gas is (P_i, V_i, T_i) . It undergoes expansion till its volume becomes V_f . Consider the following two cases:

- (a) the expansion takes place at constant temperature.
- (b) the expansion takes place at constant pressure.

Plot the P - V diagram for each case. In which of the two cases, is the work done by the gas more?

LA

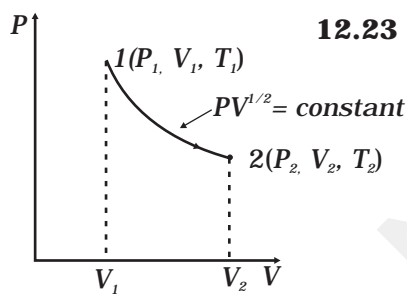

Fig. 12.9

12.23 Consider a P - V diagram in which the path followed by one mole of perfect gas in a cylindrical container is shown in Fig. 12.9.

- (a) Find the work done when the gas is taken from state 1 to state 2.
- (b) What is the ratio of temperature T_1/T_2 , if $V_2 = 2V_1$?
- (c) Given the internal energy for one mole of gas at temperature T is $(3/2) RT$, find the heat supplied to the gas when it is taken from state 1 to 2, with $V_2 = 2V_1$.

12.24 A cycle followed by an engine (made of one mole of perfect gas in a cylinder with a piston) is shown in Fig. 12.10.

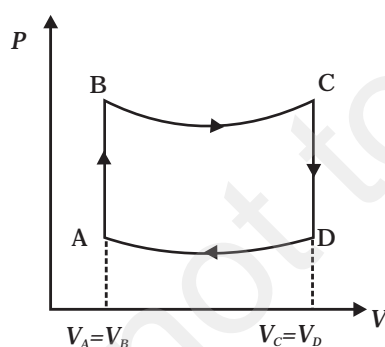

Fig. 12.10

- A to B : volume constant
- B to C : adiabatic
- C to D : volume constant
- D to A : adiabatic
- $V_C = V_D = 2V_A = 2V_B$

- (a) In which part of the cycle heat is supplied to the engine from outside?
- (b) In which part of the cycle heat is being given to the surrounding by the engine?
- (c) What is the work done by the engine in one cycle? Write your answer in term of P_A, P_B, V_A .
- (d) What is the efficiency of the engine?

$[\gamma = 5/3 \text{ for the gas}], (C_v = \frac{3}{2}R \text{ for one mole})$

12.25 A cycle followed by an engine (made of one mole of an ideal gas in a cylinder with a piston) is shown in Fig. 12.11. Find heat exchanged by the engine, with the surroundings for each section of the cycle. ($C_v = (3/2)R$)

- AB : constant volume
- BC : constant pressure
- CD : adiabatic
- DA : constant pressure

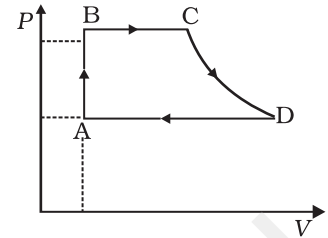

Fig. 12.11

12.26 Consider that an ideal gas (n moles) is expanding in a process given by $P = f(V)$, which passes through a point (V_0, P_0) . Show that the gas is absorbing heat at (P_0, V_0) if the slope of the curve $P = f(V)$ is larger than the slope of the adiabat passing through (P_0, V_0) .

12.27 Consider one mole of perfect gas in a cylinder of unit cross section with a piston attached (Fig. 12.12). A spring (spring constant k) is attached (unstretched length L) to the piston and to the bottom of the cylinder. Initially the spring is unstretched and the gas is in equilibrium. A certain amount of heat Q is supplied to the gas causing an increase of volume from V_0 to V_1 .

- (a) What is the initial pressure of the system?
- (b) What is the final pressure of the system?
- (c) Using the first law of thermodynamics, write down a relation between Q, P_a, V, V_0 and k .

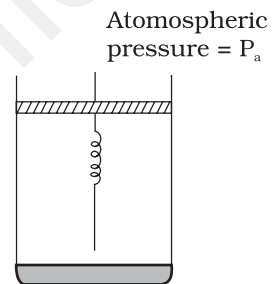

Fig. 12.12

Chapter Thirteen

KINETIC THEORY



MCQ I

- 13.1** A cubic vessel (with faces horizontal + vertical) contains an ideal gas at NTP. The vessel is being carried by a rocket which is moving at a speed of 500 m s^{-1} in vertical direction. The pressure of the gas inside the vessel as observed by us on the ground
- (a) remains the same because 500 m s^{-1} is very much smaller than v_{rms} of the gas.
 - (b) remains the same because motion of the vessel as a whole does not affect the relative motion of the gas molecules and the walls.
 - (c) will increase by a factor equal to $(v_{rms}^2 + (500)^2) / v_{rms}^2$ where v_{rms} was the original mean square velocity of the gas.
 - (d) will be different on the top wall and bottom wall of the vessel.
- 13.2** 1 mole of an ideal gas is contained in a cubical volume V , ABCDEFGH at 300 K (Fig. 13.1). One face of the cube (EFGH) is made up of a material which totally absorbs any gas molecule

incident on it. At any given time,

- the pressure on EFGH would be zero.
- the pressure on all the faces will be equal.
- the pressure on EFGH would be double the pressure on ABCD.
- the pressure on EFGH would be half that on ABCD.

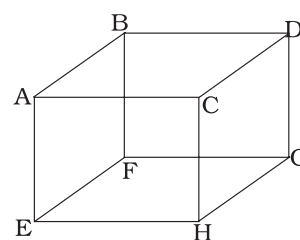

Fig. 13.1

13.3 Boyle's law is applicable for an

- adiabatic process.
- isothermal process.
- isobaric process.
- isochoric process.

13.4 A cylinder containing an ideal gas is in vertical position and has a piston of mass M that is able to move up or down without friction (Fig. 13.2). If the temperature is increased,

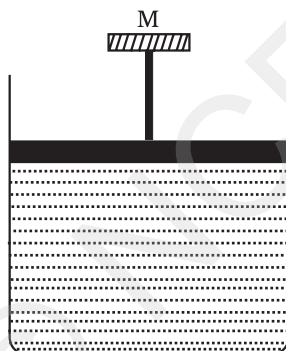

Fig. 13.2

- both p and V of the gas will change.
- only p will increase according to Charles's law.
- V will change but not p .
- p will change but not V .

13.5 Volume versus temperature graphs for a given mass of an ideal gas are shown in Fig. 13.3 at two different values of constant pressure. What can be inferred about relation between P_1 & P_2 ?

- $P_1 > P_2$
- $P_1 = P_2$
- $P_1 < P_2$
- data is insufficient.

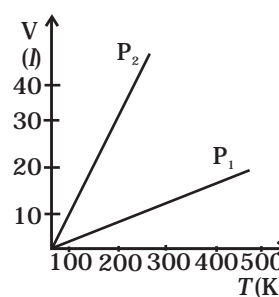

Fig. 13.3

- 13.6** 1 mole of H_2 gas is contained in a box of volume $V = 1.00 \text{ m}^3$ at $T = 300\text{K}$. The gas is heated to a temperature of $T = 3000\text{K}$ and the gas gets converted to a gas of hydrogen atoms. The final pressure would be (considering all gases to be ideal)
- same as the pressure initially.
 - 2 times the pressure initially.
 - 10 times the pressure initially.
 - 20 times the pressure initially.
- 13.7** A vessel of volume V contains a mixture of 1 mole of Hydrogen and 1 mole of Oxygen (both considered as ideal). Let $f_1(v)dv$, denote the fraction of molecules with speed between v and $(v + dv)$ with $f_2(v)dv$, similarly for oxygen. Then
- $f_1(v) + f_2(v) = f(v)$ obeys the Maxwell's distribution law.
 - $f_1(v)$, $f_2(v)$ will obey the Maxwell's distribution law separately.
 - Neither $f_1(v)$, nor $f_2(v)$ will obey the Maxwell's distribution law.
 - $f_2(v)$ and $f_1(v)$ will be the same.
- 13.8** An inflated rubber balloon contains one mole of an ideal gas, has a pressure p , volume V and temperature T . If the temperature rises to $1.1 T$, and the volume is increased to $1.05 V$, the final pressure will be
- $1.1 p$
 - p
 - less than p
 - between p and $1.1 p$.

MCQ II

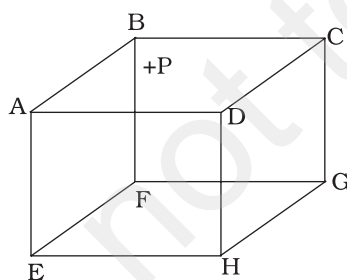

Fig. 13.4

- 13.9** ABCDEFGH is a hollow cube made of an insulator (Fig. 13.4). Face ABCD has positive charge on it. Inside the cube, we have ionized hydrogen.
- The usual kinetic theory expression for pressure
- will be valid.
 - will not be valid since the ions would experience forces other than due to collisions with the walls.
 - will not be valid since collisions with walls would not be elastic.
 - will not be valid because isotropy is lost.
- 13.10** Diatomic molecules like hydrogen have energies due to both translational as well as rotational motion. From the equation in

kinetic theory $pV = \frac{2}{3} E$, E is

- (a) the total energy per unit volume.
- (b) only the translational part of energy because rotational energy is very small compared to the translational energy.
- (c) only the translational part of the energy because during collisions with the wall pressure relates to change in linear momentum.
- (d) the translational part of the energy because rotational energies of molecules can be of either sign and its average over all the molecules is zero.

13.11 In a diatomic molecule, the rotational energy at a given temperature

- (a) obeys Maxwell's distribution.
- (b) have the same value for all molecules.
- (c) equals the translational kinetic energy for each molecule.
- (d) is (2/3)rd the translational kinetic energy for each molecule.

13.12 Which of the following diagrams (Fig. 13.5) depicts ideal gas behaviour?

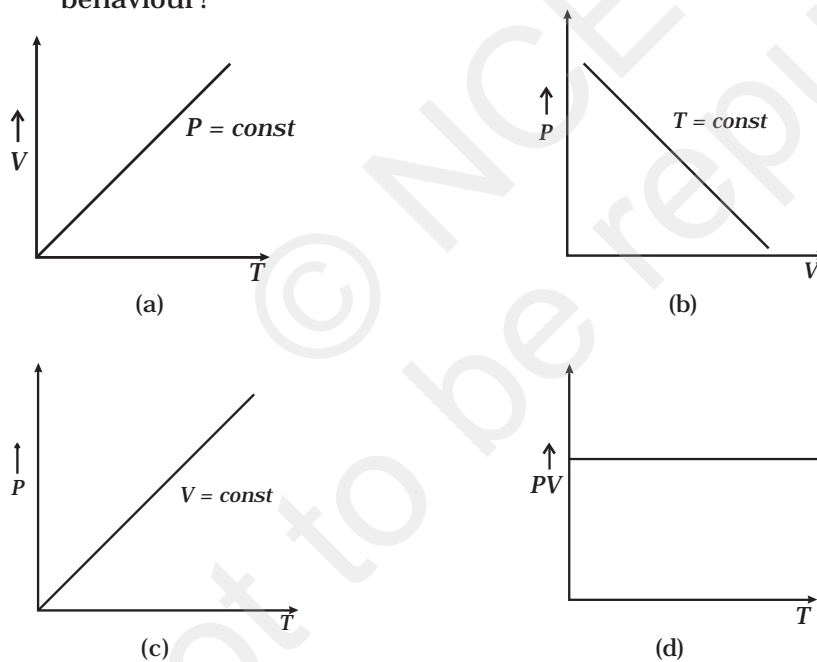

Fig. 13.5

13.13 When an ideal gas is compressed adiabatically, its temperature rises: the molecules on the average have more kinetic energy than before. The kinetic energy increases,

- (a) because of collisions with moving parts of the wall only.
- (b) because of collisions with the entire wall.

- (c) because the molecules gets accelerated in their motion inside the volume.
 (d) because of redistribution of energy amongst the molecules.

VSA

- 13.14** Calculate the number of atoms in 39.4 g gold. Molar mass of gold is 197g mole⁻¹.
- 13.15** The volume of a given mass of a gas at 27°C, 1 atm is 100 cc. What will be its volume at 327°C?
- 13.16** The molecules of a given mass of a gas have root mean square speeds of 100 m s⁻¹ at 27°C and 1.00 atmospheric pressure. What will be the root mean square speeds of the molecules of the gas at 127°C and 2.0 atmospheric pressure?
- 13.17** Two molecules of a gas have speeds of 9×10^6 m s⁻¹ and 1×10^6 m s⁻¹, respectively. What is the root mean square speed of these molecules.
- 13.18** A gas mixture consists of 2.0 moles of oxygen and 4.0 moles of neon at temperature T . Neglecting all vibrational modes, calculate the total internal energy of the system. (Oxygen has two rotational modes.)
- 13.19** Calculate the ratio of the mean free paths of the molecules of two gases having molecular diameters 1 \AA and 2 \AA . The gases may be considered under identical conditions of temperature, pressure and volume.

SA

V_1	V_2
μ_1, p_1	μ_2, p_2

Fig 13.6

- 13.20** The container shown in Fig. 13.6 has two chambers, separated by a partition, of volumes $V_1 = 2.0$ litre and $V_2 = 3.0$ litre. The chambers contain $\mu_1 = 4.0$ and $\mu_2 = 5.0$ moles of a gas at pressures $p_1 = 1.00$ atm and $p_2 = 2.00$ atm. Calculate the pressure after the partition is removed and the mixture attains equilibrium.
- 13.21** A gas mixture consists of molecules of types A, B and C with masses $m_A > m_B > m_C$. Rank the three types of molecules in decreasing order of (a) average K.E., (b) rms speeds.

- 13.22** We have 0.5 g of hydrogen gas in a cubic chamber of size 3cm kept at NTP. The gas in the chamber is compressed keeping the temperature constant till a final pressure of 100 atm. Is one justified in assuming the ideal gas law, in the final state?
(Hydrogen molecules can be consider as spheres of radius 1 \AA).
- 13.23** When air is pumped into a cycle tyre the volume and pressure of the air in the tyre both are increased. What about Boyle's law in this case?
- 13.24** A ballon has 5.0 g mole of helium at 7°C . Calculate
(a) the number of atoms of helium in the balloon,
(b) the total internal energy of the system.
- 13.25** Calculate the number of degrees of freedom of molecules of hydrogen in 1 cc of hydrogen gas at NTP.
- 13.26** An insulated container containing monoatomic gas of molar mass m is moving with a velocity v_0 . If the container is suddenly stopped, find the change in temperature.

LA

- 13.27** Explain why
(a) there is no atmosphere on moon.
(b) there is fall in temperature with altitude.
- 13.28** Consider an ideal gas with following distribution of speeds.

Speed (m/s)	% of molecules
200	10
400	20
600	40
800	20
1000	10

- (i) Calculate V_{rms} and hence T . ($m = 3.0 \times 10^{-26} \text{ kg}$)
(ii) If all the molecules with speed 1000 m/s escape from the system, calculate new V_{rms} and hence T .

- 13.29** Ten small planes are flying at a speed of 150 km/h in total darkness in an air space that is $20 \times 20 \times 1.5 \text{ km}^3$ in volume. You are in one of the planes, flying at random within this space with no way of knowing where the other planes are. On the average about how long a time will elapse between near collision with your plane. Assume for this rough computation that a safety region around the plane can be approximated by a sphere of radius 10m.
- 13.30** A box of 1.00m^3 is filled with nitrogen at 1.50 atm at 300K. The box has a hole of an area 0.010 mm^2 . How much time is required for the pressure to reduce by 0.10 atm, if the pressure outside is 1 atm.
- 13.31** Consider a rectangular block of wood moving with a velocity v_0 in a gas at temperature T and mass density ρ . Assume the velocity is along x -axis and the area of cross-section of the block perpendicular to v_0 is A . Show that the drag force on the block is $4\rho Av_0\sqrt{\frac{kT}{m}}$, where m is the mass of the gas molecule.

Chapter Fourteen

OSCILLATIONS



MCQ I

14.1 The displacement of a particle is represented by the equation

$$y = 3 \cos \left(\frac{\pi}{4} - 2\omega t \right).$$

The motion of the particle is

- (a) simple harmonic with period $2\pi/\omega$.
- (b) simple harmonic with period π/ω .
- (c) periodic but not simple harmonic.
- (d) non-periodic.

14.2 The displacement of a particle is represented by the equation

$$y = \sin^3 \omega t. \text{ The motion is}$$

- (a) non-periodic.
- (b) periodic but not simple harmonic.
- (c) simple harmonic with period $2\pi/\omega$.
- (d) simple harmonic with period π/ω .

14.3 The relation between acceleration and displacement of four particles are given below:

- (a) $a_x = + 2x$.
- (b) $a_x = + 2x^2$.
- (c) $a_x = - 2x^2$.
- (d) $a_x = - 2x$.

Which one of the particles is executing simple harmonic motion?

14.4 Motion of an oscillating liquid column in a U-tube is

- (a) periodic but not simple harmonic.
- (b) non-periodic.
- (c) simple harmonic and time period is independent of the density of the liquid.
- (d) simple harmonic and time-period is directly proportional to the density of the liquid.

14.5 A particle is acted simultaneously by mutually perpendicular simple harmonic motions $x = a \cos \omega t$ and $y = a \sin \omega t$. The trajectory of motion of the particle will be

- (a) an ellipse.
- (b) a parabola.
- (c) a circle.
- (d) a straight line.

14.6 The displacement of a particle varies with time according to the relation

$$y = a \sin \omega t + b \cos \omega t.$$

- (a) The motion is oscillatory but not S.H.M.
- (b) The motion is S.H.M. with amplitude $a + b$.
- (c) The motion is S.H.M. with amplitude $a^2 + b^2$.
- (d) The motion is S.H.M. with amplitude $\sqrt{a^2 + b^2}$.

14.7 Four pendulums A, B, C and D are suspended from the same

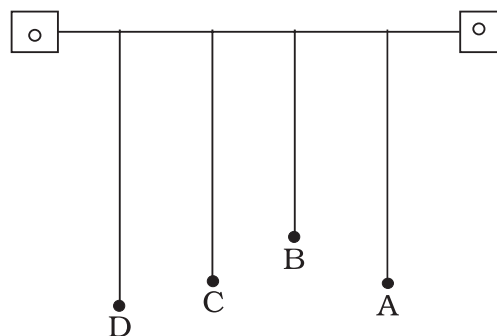

Fig. 14.1

elastic support as shown in Fig. 14.1. A and C are of the same length, while B is smaller than A and D is larger than A. If A is given a transverse displacement,

- D will vibrate with maximum amplitude.
- C will vibrate with maximum amplitude.
- B will vibrate with maximum amplitude.
- All the four will oscillate with equal amplitude.

14.8 Figure 14.2. shows the circular motion of a particle. The radius of the circle, the period, sense of revolution and the initial position are indicated on the figure. The simple harmonic motion of the x-projection of the radius vector of the rotating particle P is

(a) $x(t) = B \sin\left(\frac{2\pi t}{30}\right)$.

(b) $x(t) = B \cos\left(\frac{\pi t}{15}\right)$.

(c) $x(t) = B \sin\left(\frac{\pi t}{15} + \frac{\pi}{2}\right)$.

(d) $x(t) = B \cos\left(\frac{\pi t}{15} + \frac{\pi}{2}\right)$.

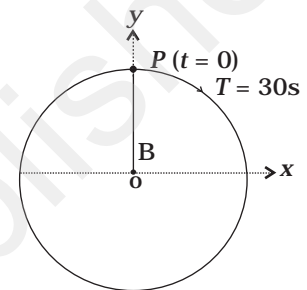

Fig. 14.2

14.9 The equation of motion of a particle is $x = a \cos(\alpha t)^2$.

The motion is

- periodic but not oscillatory.
- periodic and oscillatory.
- oscillatory but not periodic.
- neither periodic nor oscillatory.

14.10 A particle executing S.H.M. has a maximum speed of 30 cm/s and a maximum acceleration of 60 cm/s². The period of oscillation is

- π s.
- $\frac{\pi}{2}$ s.
- 2π s.
- $\frac{\pi}{t}$ s.

14.11 When a mass m is connected individually to two springs S_1 and S_2 , the oscillation frequencies are ν_1 and ν_2 . If the same mass is

attached to the two springs as shown in Fig. 14.3, the oscillation frequency would be

- (a) $\nu_1 + \nu_2$.
- (b) $\sqrt{\nu_1^2 + \nu_2^2}$.
- (c) $\left(\frac{1}{\nu_1} + \frac{1}{\nu_2}\right)^{-1}$.
- (d) $\sqrt{\nu_1^2 - \nu_2^2}$.

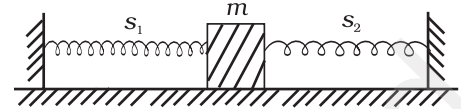

Fig. 14.3

MCQ II

14.12 The rotation of earth about its axis is

- (a) periodic motion.
 (b) simple harmonic motion.
 (c) periodic but not simple harmonic motion.
 (d) non-periodic motion.

14.13 Motion of a ball bearing inside a smooth curved bowl, when released from a point slightly above the lower point is

- (a) simple harmonic motion.
 (b) non-periodic motion.
 (c) periodic motion.
 (d) periodic but not S.H.M.

14.14 Displacement vs. time curve for a particle executing S.H.M. is shown in Fig. 14.4. Choose the correct statements.

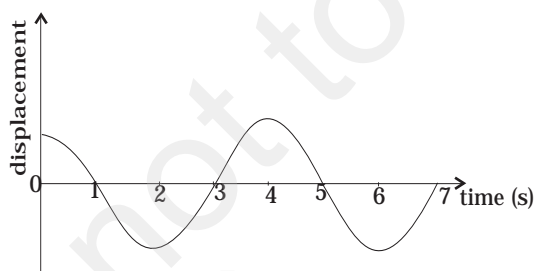

Fig. 14.4

- (a) Phase of the oscillator is same at $t = 0$ s and $t = 2$ s.
 (b) Phase of the oscillator is same at $t = 2$ s and $t = 6$ s.
 (c) Phase of the oscillator is same at $t = 1$ s and $t = 7$ s.
 (d) Phase of the oscillator is same at $t = 1$ s and $t = 5$ s.

14.15 Which of the following statements is/are true for a simple harmonic oscillator?

- (a) Force acting is directly proportional to displacement from the mean position and opposite to it.

- (b) Motion is periodic.
- (c) Acceleration of the oscillator is constant.
- (d) The velocity is periodic.

14.16 The displacement time graph of a particle executing S.H.M. is shown in Fig. 14.5. Which of the following statement is/are true?

- (a) The force is zero at $t = \frac{3T}{4}$.
- (b) The acceleration is maximum at $t = \frac{4T}{4}$.
- (c) The velocity is maximum at $t = \frac{T}{4}$.
- (d) The P.E. is equal to K.E. of oscillation at $t = \frac{T}{2}$.

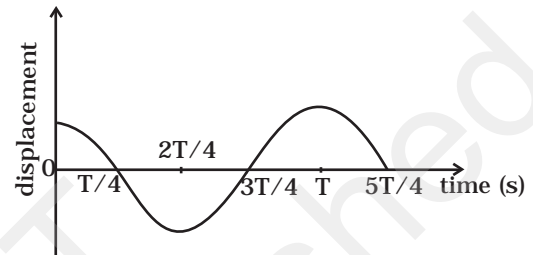

Fig.14.5

14.17 A body is performing S.H.M. Then its

- (a) average total energy per cycle is equal to its maximum kinetic energy.
- (b) average kinetic energy per cycle is equal to half of its maximum kinetic energy.
- (c) mean velocity over a complete cycle is equal to $\frac{2}{\pi}$ times of its maximum velocity.
- (d) root mean square velocity is $\frac{1}{\sqrt{2}}$ times of its maximum velocity.

14.18 A particle is in linear simple harmonic motion between two points A and B, 10 cm apart (Fig. 14.6). Take the direction from A to B as the +ve direction and choose the correct statements.



AO = OB = 5cm
BC = 8cm

Fig. 14.6

- (a) The sign of velocity, acceleration and force on the particle when it is 3 cm away from A going towards B are positive.
- (b) The sign of velocity of the particle at C going towards O is negative.
- (c) The sign of velocity, acceleration and force on the particle when it is 4 cm away from B going towards A are negative.
- (d) The sign of acceleration and force on the particle when it is at point B is negative.

VSA

- 14.19** Displacement versus time curve for a particle executing S.H.M. is shown in Fig. 14.7. Identify the points marked at which (i) velocity of the oscillator is zero, (ii) speed of the oscillator is maximum.

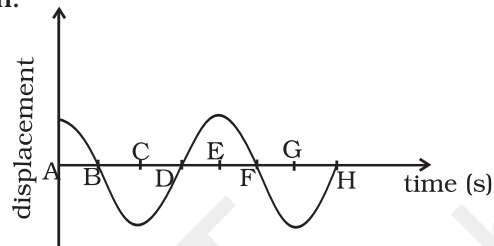

Fig. 14.7

- 14.20** Two identical springs of spring constant K are attached to a block of mass m and to fixed supports as shown in Fig. 14.8. When the mass is displaced from equilibrium position by a distance x towards right, find the restoring force

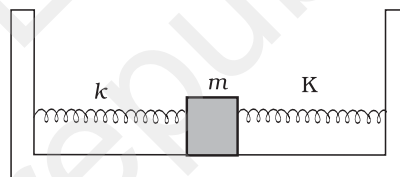

Fig. 14.8

- 14.21** What are the two basic characteristics of a simple harmonic motion?
- 14.22** When will the motion of a simple pendulum be simple harmonic?
- 14.23** What is the ratio of maximum acceleration to the maximum velocity of a simple harmonic oscillator?
- 14.24** What is the ratio between the distance travelled by the oscillator in one time period and amplitude?
- 14.25** In Fig. 14.9, what will be the sign of the velocity of the point p' , which is the projection of the velocity of the reference particle P . P is moving in a circle of radius R in anticlockwise direction.

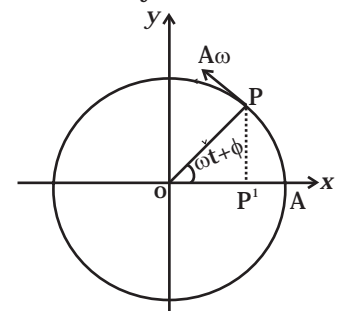

Fig. 14.9

- 14.26** Show that for a particle executing S.H.M, velocity and displacement have a phase difference of $\pi/2$.
- 14.27** Draw a graph to show the variation of P.E., K.E. and total energy of a simple harmonic oscillator with displacement.
- 14.28** The length of a second's pendulum on the surface of Earth is 1m. What will be the length of a second's pendulum on the moon?

SA

- 14.29** Find the time period of mass M when displaced from its equilibrium position and then released for the system shown in Fig 14.10.
- 14.30** Show that the motion of a particle represented by $y = \sin \omega t - \cos \omega t$ is simple harmonic with a period of $2\pi/\omega$.
- 14.31** Find the displacement of a simple harmonic oscillator at which its P.E. is half of the maximum energy of the oscillator.
- 14.32** A body of mass m is situated in a potential field $U(x) = U_0 (1 - \cos \alpha x)$ when U_0 and α are constants. Find the time period of small oscillations.
- 14.33** A mass of 2 kg is attached to the spring of spring constant 50 Nm^{-1} . The block is pulled to a distance of 5cm from its equilibrium position at $x = 0$ on a horizontal frictionless surface from rest at $t = 0$. Write the expression for its displacement at anytime t .
- 14.34** Consider a pair of identical pendulums, which oscillate with equal amplitude independently such that when one pendulum is at its extreme position making an angle of 2° to the right with the vertical, the other pendulum makes an angle of 1° to the left of the vertical. What is the phase difference between the pendulums?



Fig. 14.10

LA

- 14.35** A person normally weighing 50 kg stands on a massless platform which oscillates up and down harmonically at a frequency of 2.0 s^{-1} and an amplitude 5.0 cm. A weighing machine on the platform gives the persons weight against time.
- (a) Will there be any change in weight of the body, during the oscillation?

(b) If answer to part (a) is yes, what will be the maximum and minimum reading in the machine and at which position?

14.36 A body of mass m is attached to one end of a massless spring which is suspended vertically from a fixed point. The mass is held in hand so that the spring is neither stretched nor compressed. Suddenly the support of the hand is removed. The lowest position attained by the mass during oscillation is 4cm below the point, where it was held in hand.

(a) What is the amplitude of oscillation?

(b) Find the frequency of oscillation?

14.37 A cylindrical log of wood of height h and area of cross-section A floats in water. It is pressed and then released. Show that the log would execute S.H.M. with a time period.

$$T = 2\pi \sqrt{\frac{m}{A\rho g}}$$

where m is mass of the body and ρ is density of the liquid.

14.38 One end of a V-tube containing mercury is connected to a suction pump and the other end to atmosphere. The two arms of the tube are inclined to horizontal at an angle of 45° each. A small pressure difference is created between two columns when the suction pump is removed. Will the column of mercury in V-tube execute simple harmonic motion? Neglect capillary and viscous forces. Find the time period of oscillation.

14.39 A tunnel is dug through the centre of the Earth. Show that a body of mass ' m ' when dropped from rest from one end of the tunnel will execute simple harmonic motion.

14.40 A simple pendulum of time period 1s and length l is hung from a fixed support at O, such that the bob is at a distance H vertically above A on the ground (Fig. 14.11). The amplitude is θ_0 . The string snaps at $\theta = \theta_0/2$. Find the time taken by the bob to hit the ground. Also find distance from A where bob hits the ground. Assume θ_0 to be small so that $\sin \theta_0 \approx \theta_0$ and $\cos \theta_0 \approx 1$.

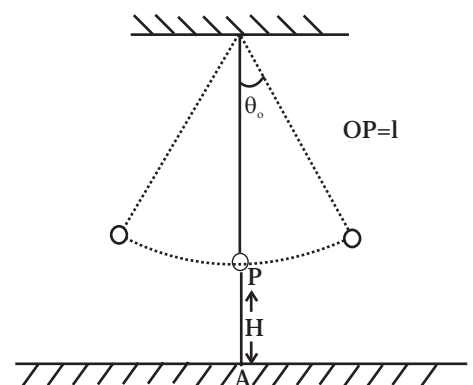

Fig. 14.11

Chapter Fifteen

WAVES



MCQ I

- 15.1** Water waves produced by a motor boat sailing in water are
- (a) neither longitudinal nor transverse.
 - (b) both longitudinal and transverse.
 - (c) only longitudinal.
 - (d) only transverse.
- 15.2** Sound waves of wavelength λ travelling in a medium with a speed of v m/s enter into another medium where its speed is $2v$ m/s. Wavelength of sound waves in the second medium is
- (a) λ
 - (b) $\frac{\lambda}{2}$
 - (c) 2λ
 - (d) 4λ

- 15.3** Speed of sound wave in air
- (a) is independent of temperature.
 - (b) increases with pressure.
 - (c) increases with increase in humidity.
 - (d) decreases with increase in humidity.
- 15.4** Change in temperature of the medium changes
- (a) frequency of sound waves.
 - (b) amplitude of sound waves.
 - (c) wavelength of sound waves.
 - (d) loudness of sound waves.
- 15.5** With propagation of longitudinal waves through a medium, the quantity transmitted is
- (a) matter.
 - (b) energy.
 - (c) energy and matter.
 - (d) energy, matter and momentum.
- 15.6** Which of the following statements are true for wave motion?
- (a) Mechanical transverse waves can propagate through all mediums.
 - (b) Longitudinal waves can propagate through solids only.
 - (c) Mechanical transverse waves can propagate through solids only.
 - (d) Longitudinal waves can propagate through vacuum.
- 15.7** A sound wave is passing through air column in the form of compression and rarefaction. In consecutive compressions and rarefactions,
- (a) density remains constant.
 - (b) Boyle's law is obeyed.
 - (c) bulk modulus of air oscillates.
 - (d) there is no transfer of heat.
- 15.8** Equation of a plane progressive wave is given by $y = 0.6 \sin 2\pi \left(t - \frac{x}{2} \right)$. On reflection from a denser medium its amplitude becomes $\frac{2}{3}$ of the amplitude of the incident wave. The equation of the reflected wave is
- (a) $y = 0.6 \sin 2\pi \left(t + \frac{x}{2} \right)$

$$(b) y = -0.4 \sin 2\pi \left(t + \frac{x}{2} \right)$$

$$(c) y = 0.4 \sin 2\pi \left(t + \frac{x}{2} \right)$$

$$(d) y = -0.4 \sin 2\pi \left(t - \frac{x}{2} \right).$$

15.9 A string of mass 2.5 kg is under a tension of 200 N. The length of the stretched string is 20.0 m. If the transverse jerk is struck at one end of the string, the disturbance will reach the other end in

- (a) one second
- (b) 0.5 second
- (c) 2 seconds
- (d) data given is insufficient.

15.10 A train whistling at constant frequency is moving towards a station at a constant speed V . The train goes past a stationary observer on the station. The frequency n' of the sound as heard by the observer is plotted as a function of time t (Fig 15.1). Identify the expected curve.

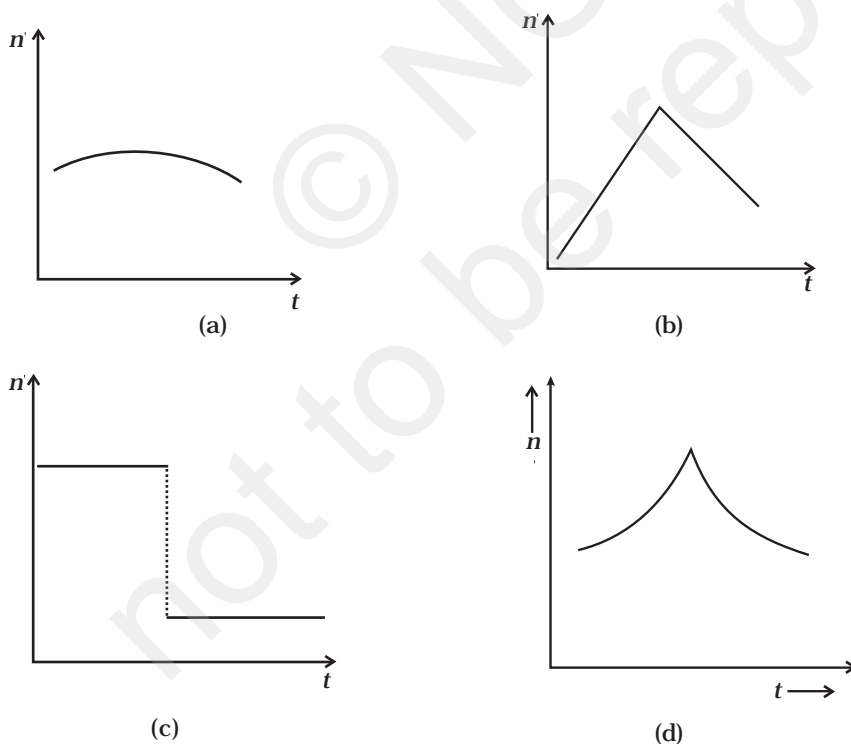

Fig 15.1

MCQ II

15.11 A transverse harmonic wave on a string is described by $y(x,t) = 3.0 \sin(36t + 0.018x + \pi/4)$

where x and y are in cm and t is in s. The positive direction of x is from left to right.

- (a) The wave is travelling from right to left.
- (b) The speed of the wave is 20m/s.
- (c) Frequency of the wave is 5.7 Hz.
- (d) The least distance between two successive crests in the wave is 2.5 cm.

15.12 The displacement of a string is given by $y(x,t) = 0.06 \sin(2\pi x/3) \cos(120\pi t)$ where x and y are in m and t in s. The length of the string is 1.5m and its mass is 3.0×10^{-2} kg.

- (a) It represents a progressive wave of frequency 60Hz.
- (b) It represents a stationary wave of frequency 60Hz.
- (c) It is the result of superposition of two waves of wavelength 3 m, frequency 60Hz each travelling with a speed of 180 m/s in opposite direction.
- (d) Amplitude of this wave is constant.

15.13 Speed of sound waves in a fluid depends upon

- (a) directly on density of the medium.
- (b) square of Bulk modulus of the medium.
- (c) inversly on the square root of density.
- (d) directly on the square root of bulk modulus of the medium.

15.14 During propagation of a plane progressive mechanical wave

- (a) all the particles are vibrating in the same phase.
- (b) amplitude of all the particles is equal.
- (c) particles of the medium executes S.H.M.
- (d) wave velocity depends upon the nature of the medium.

15.15 The transverse displacement of a string (clamped at its both ends) is given by $y(x,t) = 0.06 \sin(2\pi x/3) \cos(120\pi t)$.

All the points on the string between two consecutive nodes vibrate with

- (a) same frequency
- (b) same phase
- (c) same energy
- (d) different amplitude.

- 15.16** A train, standing in a station yard, blows a whistle of frequency 400 Hz in still air. The wind starts blowing in the direction from the yard to the station with a speed of 10m/s. Given that the speed of sound in still air is 340m/s,
- (a) the frequency of sound as heard by an observer standing on the platform is 400Hz.
 - (b) the speed of sound for the observer standing on the platform is 350m/s.
 - (c) the frequency of sound as heard by the observer standing on the platform will increase.
 - (d) the frequency of sound as heard by the observer standing on the platform will decrease.
- 15.17** Which of the following statements are true for a stationary wave?
- (a) Every particle has a fixed amplitude which is different from the amplitude of its nearest particle.
 - (b) All the particles cross their mean position at the same time.
 - (c) All the particles are oscillating with same amplitude.
 - (d) There is no net transfer of energy across any plane.
 - (e) There are some particles which are always at rest.

VSA

- 15.18** A sonometer wire is vibrating in resonance with a tuning fork. Keeping the tension applied same, the length of the wire is doubled. Under what conditions would the tuning fork still be in resonance with the wire?
- 15.19** An organ pipe of length L open at both ends is found to vibrate in its first harmonic when sounded with a tuning fork of 480 Hz. What should be the length of a pipe closed at one end, so that it also vibrates in its first harmonic with the same tuning fork?
- 15.20** A tuning fork A, marked 512 Hz, produces 5 beats per second, when sounded with another unmarked tuning fork B. If B is loaded with wax the number of beats is again 5 per second. What is the frequency of the tuning fork B when not loaded?
- 15.21** The displacement of an elastic wave is given by the function
$$y = 3 \sin \omega t + 4 \cos \omega t.$$
where y is in cm and t is in second. Calculate the resultant amplitude.
- 15.22** A sitar wire is replaced by another wire of same length and material but of three times the earlier radius. If the tension in the wire remains the same, by what factor will the frequency change?

- 15.23** At what temperatures (in °C) will the speed of sound in air be 3 times its value at 0°C?
- 15.24** When two waves of almost equal frequencies n_1 and n_2 reach at a point simultaneously, what is the time interval between successive maxima?

SA

- 15.25** A steel wire has a length of 12 m and a mass of 2.10 kg. What will be the speed of a transverse wave on this wire when a tension of $2.06 \times 10^4 \text{N}$ is applied?
- 15.26** A pipe 20 cm long is closed at one end. Which harmonic mode of the pipe is resonantly excited by a source of 1237.5 Hz ?(sound velocity in air = 330 m s^{-1})
- 15.27** A train standing at the outer signal of a railway station blows a whistle of frequency 400 Hz still air. The train begins to move with a speed of 10 m s^{-1} towards the platform. What is the frequency of the sound for an observer standing on the platform? (sound velocity in air = 330 m s^{-1})
- 15.28** The wave pattern on a stretched string is shown in Fig. 15.2. Interpret what kind of wave this is and find its wavelength.

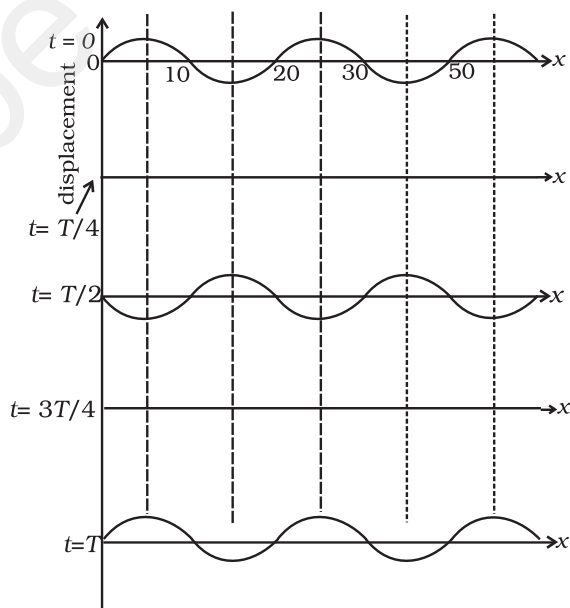

Fig. 15.2

- 15.29** The pattern of standing waves formed on a stretched string at two instants of time are shown in Fig. 15.3. The velocity of two waves superimposing to form stationary waves is 360 ms^{-1} and their frequencies are 256 Hz .

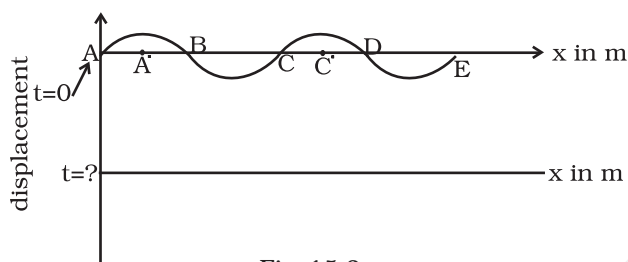

Fig. 15.3

- Calculate the time at which the second curve is plotted.
- Mark nodes and antinodes on the curve.
- Calculate the distance between A' and C' .

- 15.30** A tuning fork vibrating with a frequency of 512 Hz is kept close to the open end of a tube filled with water (Fig. 15.4). The water level in the tube is gradually lowered. When the water level is 17 cm below the open end, maximum intensity of sound is heard. If the room temperature is 20°C , calculate

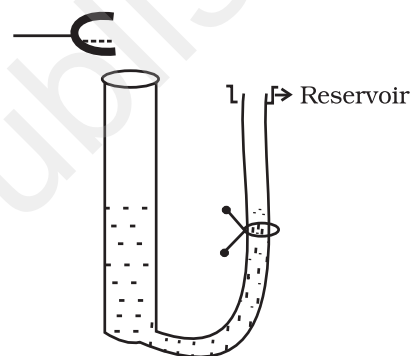

Fig. 15.4

- speed of sound in air at room temperature
- speed of sound in air at 0°C
- if the water in the tube is replaced with mercury, will there be any difference in your observations?

- 15.31** Show that when a string fixed at its two ends vibrates in 1 loop, 2 loops, 3 loops and 4 loops, the frequencies are in the ratio $1:2:3:4$.

LA

- 15.32** The earth has a radius of 6400 km . The inner core of 1000 km radius is solid. Outside it, there is a region from 1000 km to a radius of 3500 km which is in molten state. Then again from 3500 km to 6400 km the earth is solid. Only longitudinal (P) waves can travel inside a liquid. Assume that the P wave has a speed of 8 km s^{-1} in solid parts and of 5 km s^{-1} in liquid parts of the earth. An earthquake occurs at some place close to the surface of the earth. Calculate the time after which it will be recorded in a seismometer at a diametrically opposite point on the earth if wave travels along diameter?

15.33 If c is r.m.s. speed of molecules in a gas and v is the speed of sound waves in the gas, show that c/v is constant and independent of temperature for all diatomic gases.

15.34 Given below are some functions of x and t to represent the displacement of an elastic wave.

(a) $y = 5 \cos (4x) \sin (20t)$

(b) $y = 4 \sin (5x - t/2) + 3 \cos (5x - t/2)$

(c) $y = 10 \cos [(252 - 250) \pi t] \cos [(252+250)\pi t]$

(d) $y = 100 \cos (100\pi t + 0.5x)$

State which of these represent

- (a) a travelling wave along $-x$ direction
- (b) a stationary wave
- (c) beats
- (d) a travelling wave along $+x$ direction.

Given reasons for your answers.

15.35 In the given progressive wave

$$y = 5 \sin (100\pi t - 0.4\pi x)$$

where y and x are in m, t is in s. What is the

- (a) amplitude
- (b) wave length
- (c) frequency
- (d) wave velocity
- (e) particle velocity amplitude.

15.36 For the harmonic travelling wave $y = 2 \cos 2\pi (10t - 0.0080x + 3.5)$ where x and y are in cm and t is second. What is the phase difference between the oscillatory motion at two points separated by a distance of

- (a) 4 m
- (b) 0.5 m
- (c) $\frac{\lambda}{2}$
- (d) $\frac{3\lambda}{4}$ (at a given instant of time)
- (e) What is the phase difference between the oscillation of a particle located at $x = 100\text{cm}$, at $t = T$ s and $t = 5$ s?

ANSWERS

Chapter 2

- 2.1 (b)
- 2.2 (b)
- 2.3 (c)
- 2.4 (d)
- 2.5 (a)
- 2.6 (c)
- 2.7 (a)
- 2.8 (d)
- 2.9 (a)
- 2.10 (a)
- 2.11 (c)
- 2.12 (d)
- 2.13 (b), (c)
- 2.14 (a), (e)
- 2.15 (b), (d)
- 2.16 (a), (b), (d)
- 2.17 (a), (b)
- 2.18 (b), (d)
- 2.19 Because, bodies differ in order of magnitude significantly in respect to the same physical quantity. For example, interatomic distances are of the order of angstroms, inter-city distances are of the order of km, and interstellar distances are of the order of light year.

2.20 10^{15}

2.21 Mass spectrograph

2.22 $1 \text{ u} = 1.67 \times 10^{-27} \text{ kg}$

2.23 Since $f(\theta)$ is a sum of different powers of θ , it has to be dimensionless

2.24 Because all other quantities of mechanics can be expressed in terms of length, mass and time through simple relations.

2.25 (a) $\theta = \frac{R_E}{60R_E} = \frac{1}{60} \text{ rad} \approx 1^\circ$

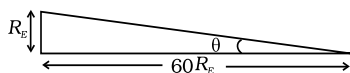

\therefore Diameter of the earth as seen from the moon is about 2° .

(b) At earth-moon distance, moon is seen as $(1/2)^\circ$ diameter and earth is seen as 2° diameter. Hence, diameter of earth is 4 times the diameter of moon.

$$\frac{D_{\text{earth}}}{D_{\text{moon}}} = 4$$

(c) $\frac{r_{\text{sun}}}{r_{\text{moon}}} = 400$

(Here r stands for distance, and D for diameter.)

Sun and moon both appear to be of the same angular diameter as seen from the earth.

$$\therefore \frac{D_{\text{sun}}}{r_{\text{sun}}} = \frac{D_{\text{moon}}}{r_{\text{moon}}}$$

$$\therefore \frac{D_{\text{sun}}}{D_{\text{moon}}} = 400$$

$$\text{But } \frac{D_{\text{earth}}}{D_{\text{moon}}} = 4 \quad \therefore \frac{D_{\text{sun}}}{D_{\text{earth}}} = 100$$

2.26 An atomic clock is the most precise time measuring device because atomic oscillations are repeated with a precision of 1s in 10^{13} s .

2.27 $3 \times 10^{16} \text{ s}$

2.28 0.01 mm

2.29 $\theta = (\pi R_s^2 / R_{es}^2)(\pi R_m^2 / R_{em}^2)$

$$\Rightarrow \frac{R_s}{R_m} = \frac{R_{es}}{R_{em}}$$

2.30 10^5 kg

- 2.31 (a) Angle or solid angle
 (b) Relative density, etc.
 (c) Planck's constant, universal gravitational constant, etc.
 (d) Raynold number

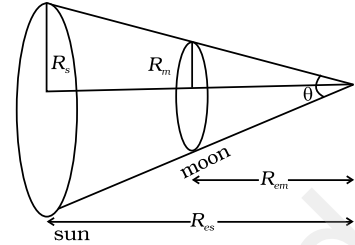

2.32 $\theta = \frac{l}{r} \Rightarrow l = r\theta \Rightarrow l = 31 \times \frac{3.14}{6} \text{ cm} = 16.3 \text{ cm}$

2.33 4×10^{-2} steradian

2.34 Dimensional formula of $\omega = T^{-1}$
 Dimensional formula of $k = L^{-1}$

2.35 (a) Precision is given by the least count of the instrument.

For 20 oscillations, precision = 0.1 s

For 1 oscillation, precision = 0.005 s.

(b) Average time $t = \frac{39.6 + 39.9 + 39.5}{3} \text{ s} = 39.6 \text{ s}$

Period = $\frac{39.6}{20} = 1.98 \text{ s}$

Max. observed error = $(1.995 - 1.980) \text{ s} = 0.015 \text{ s}$.

2.36 Since energy has dimensions of $ML^2 T^{-2}$, 1J in new units becomes $\gamma^2 / \alpha\beta^2 \text{ J}$. Hence 5 J becomes $5\gamma^2 / \alpha\beta^2$.

2.37 The dimensional part in the expression is $\frac{\rho r^4}{\eta l}$. Therefore, the dimensions of the right hand side comes out to be

$$\frac{[ML^{-1}T^{-2}][L^4]}{[ML^{-1}T^{-1}][L]} = \frac{[L^3]}{[T]}$$

which is volume upon time. Hence, the formula is dimensionally correct.

2.38 The fractional error in X is

$$\frac{dX}{X} = \frac{2da}{a} + \frac{3db}{b} + \frac{2.5dc}{c} + \frac{2d(d)}{d}$$

$$= 0.235 = 0.24$$

Since the error is in first decimal, hence the result should be rounded off as 2.8.

2.39 Since E, l and G have dimensional formulas:

$$E \rightarrow ML^2T^{-2}$$

$$l \rightarrow ML^2T^{-1}$$

$$G \rightarrow L^3M^{-1}T^{-2}$$

Hence, $P = E l^2 m^{-5} G^{-2}$ will have dimensions:

$$\begin{aligned} [P] &= \frac{[ML^2T^{-2}][M^2L^4T^{-2}][M^2T^4]}{[M^5][L^6]} \\ &= M^0L^0T^0 \end{aligned}$$

Thus, P is dimensionless.

2.40 M, L, T, in terms of new units become

$$M \rightarrow \sqrt{\frac{ch}{G}}, L \rightarrow \sqrt{\frac{hG}{c^3}}, T \rightarrow \sqrt{\frac{hG}{c^5}}$$

2.41 Given $T^2 \propto r^3 \Rightarrow T \propto r^{3/2}$. T is also function of g and

$$R \Rightarrow T \propto g^x R^y$$

$$\therefore [L^0M^0T^1] = [L^{3/2}M^0T^0][L^1M^0T^{-2}]^x [L^1M^0T^0]^y$$

$$\text{For L, } 0 = \frac{3}{2} + x + y$$

$$\text{For T, } 1 = 0 - 2x \Rightarrow x = -\frac{1}{2}$$

$$\text{Therefore, } 0 = \frac{3}{2} - \frac{1}{2} + y \Rightarrow y = -1$$

$$\text{Thus, } T = kr^{3/2}g^{-1/2}R^{-1} = \frac{k}{R}\sqrt{\frac{r^3}{g}}$$

- 2.42** (a) Because oleic acid dissolves in alcohol but does not dissolve in water.
- (b) When lycopodium powder is spread on water, it spreads on the entire surface. When a drop of the prepared solution is dropped on water, oleic acid does not dissolve in water, it spreads on the water surface pushing the lycopodium powder away to clear a circular area where the drop falls. This allows measuring the area where oleic acid spreads.

- (c) $\frac{1}{20} \text{ mL} \times \frac{1}{20} = \frac{1}{400} \text{ mL}$
- (d) By means of a burette and measuring cylinder and measuring the number of drops.
- (e) If n drops of the solution make 1 mL, the volume of oleic acid in one drop will be $(1/400)n$ mL.

2.43 (a) By definition of parsec

$$\therefore 1 \text{ parsec} = \left(\frac{1 \text{ A.U.}}{1 \text{ arc sec}} \right)$$

$$1 \text{ deg} = 3600 \text{ arc sec}$$

$$\therefore 1 \text{ arcsec} = \frac{\pi}{3600 \times 180} \text{ radians}$$

$$\therefore 1 \text{ parsec} = \frac{3600 \times 180}{\pi} \text{ A.U.} = 206265 \text{ A.U.} \approx 2 \times 10^5 \text{ A.U.}$$

(b) At 1 A.U. distance, sun is $(1/2^\circ)$ in diameter.

Therefore, at 1 parsec, star is $\frac{1/2}{2 \times 10^5}$ degree in diameter = 15×10^{-5} arcmin.

With 100 magnification, it should look 15×10^{-3} arcmin. However, due to atmospheric fluctuations, it will still look of about 1 arcmin.

It can't be magnified using telescope.

(c) $\frac{D_{\text{mars}}}{D_{\text{earth}}} = \frac{1}{2}, \quad \frac{D_{\text{earth}}}{D_{\text{sun}}} = \frac{1}{400}$ [from Answer 2.25 (c)]

$$\therefore \frac{D_{\text{mars}}}{D_{\text{sun}}} = \frac{1}{800}$$

At 1 A.U. sun is seen as $1/2$ degree in diameter, and mars will be seen as $1/1600$ degree in diameter.

At $1/2$ A.U. mars will be seen as $1/800$ degree in diameter. With 100 magnification mars will be seen as $1/8$ degree = $\frac{60}{8} = 7.5$ arcmin.

This is larger than resolution limit due to atmospheric fluctuations. Hence, it looks magnified.

2.44 (a) Since $1 \text{ u} = 1.67 \times 10^{-27} \text{ kg}$, its energy equivalent is $1.67 \times 10^{-27} c^2$ in SI units. When converted to eV and MeV, it turns out to be $1 \text{ u} \equiv 931.5 \text{ MeV}$.

(b) $1 \text{ u} \times c^2 = 931.5 \text{ MeV}$.

Chapter 3

- 3.1 (b)
- 3.2 (a)
- 3.3 (b)
- 3.4 (c)
- 3.5 (b)
- 3.6 (c)
- 3.7 (a), (c), (d)
- 3.8 (a), (c), (e)
- 3.9 (a), (d)
- 3.10 (a), (c)
- 3.11 (b), (c), (d)
- 3.12 (a) (iii), (b) (ii), (c) iv, (d) (i)

3.13

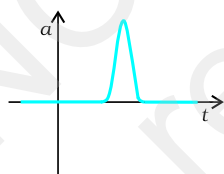

- 3.14 (i) $x(t) = t - \sin t$
- (ii) $x(t) = \sin t$

3.15 $x(t) = A + B e^{-\gamma t}$; $A > B$, $\gamma > 0$ are suitably chosen positive constants.

3.16 $v = g/b$

3.17 The ball is released and is falling under gravity. Acceleration is $-g$, except for the short time intervals in which the ball collides with

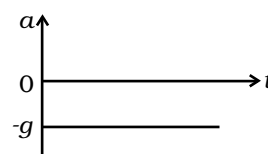
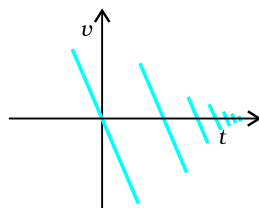

ground, and when the impulsive force acts and produces a large acceleration.

3.18 (a) $x = 0, v = \gamma x_0$

3.19 Relative speed of cars = 45 km/h, time required to meet
 $= \frac{36 \text{ km}}{45 \text{ km/h}} = 0.80 \text{ h}$

Thus, distance covered by the bird = 36 km/h \times 0.8h = 28.8 km.

3.20 Suppose that the fall of 9 m will take time t . Hence

$$y - y_0 = v_{oy}t - \frac{gt^2}{2}$$

Since $v_{oy} = 0$,

$$t = \sqrt{\frac{2(y - y_0)}{g}} \rightarrow \sqrt{\frac{2 \times 9 \text{ m}}{10 \text{ m/s}^2}} = \sqrt{1.8} \approx 1.34 \text{ seconds.}$$

In this time, the distance moved horizontally is

$$x - x_0 = v_{ox}t = 9 \text{ m/s} \times 1.34 \text{ s} = 12.06 \text{ m.}$$

Yes-he will land.

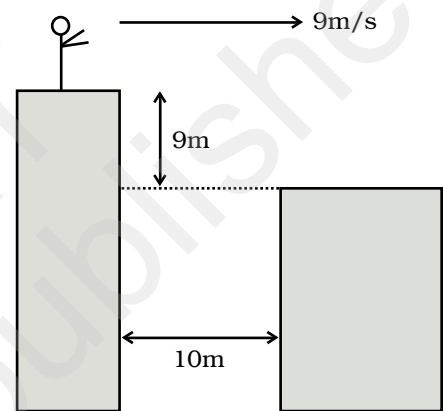

3.21 Both are free falling. Hence, there is no acceleration of one w.r.t. another. Therefore, relative speed remains constant (=40 m/s).

3.22 $v = (-v_0/x_0) x + v_0, a = (v_0/x_0)^2 x - v_0^2/x_0$

The variation of a with x is shown in the figure. It is a straight line with a positive slope and a negative intercept.

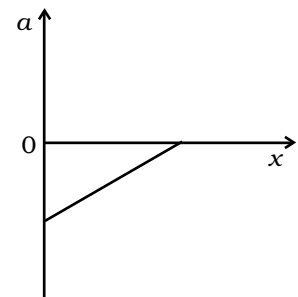

3.23 (a) $v = \sqrt{2gh} = \sqrt{2 \times 10 \times 1000} = 141 \text{ m/s} = 510 \text{ km/h.}$

(b) $m = \frac{4\pi}{3} r^3 \rho = \frac{4\pi}{3} (2 \times 10^{-3})^3 (10^3) = 3.4 \times 10^{-5} \text{ kg.}$

$$P = mv \approx 4.7 \times 10^{-3} \text{ kg m/s} \approx 5 \times 10^{-3} \text{ kg m/s.}$$

(c) Diameter $\approx 4 \text{ mm}$

$$\Delta t \approx d / v = 28 \mu\text{s} \approx 30 \mu\text{s}$$

(d) $F = \frac{\Delta P}{\Delta t} = \frac{4.7 \times 10^{-3}}{28 \times 10^{-6}} \approx 168 \text{ N} \approx 1.7 \times 10^2 \text{ N.}$

(e) Area of cross-section = $\pi d^2 / 4 \approx 0.8 \text{ m}^2.$

With average separation of 5 cm, no. of drops that will fall almost simultaneously is $\frac{0.8\text{m}^2}{(5 \times 10^{-2})^2} \approx 320$.

Net force ≈ 54000 N (Practically drops are damped by air viscosity).

3.24 Car behind the truck

$$\text{Regardation of truck} = \frac{20}{5} = 4\text{ms}^{-2}$$

$$\text{Regardation of car} = \frac{20}{3}\text{ms}^{-2}$$

Let the truck be at a distance x from the car when breaks are applied

$$\text{Distance of truck from A at } t > 0.5 \text{ s is } x + 20t - 2t^2.$$

$$\text{Distance of car from A is } 10 + 20(t - 0.5) - \frac{10}{3}(t - 0.5)^2.$$

If the two meet

$$x + 20t - 2t^2 = 10 + 20t - 10 - \frac{10}{3}t^2 + \frac{10}{3}t - 0.25 \times \frac{10}{3}.$$

$$x = -\frac{4}{3}t^2 + \frac{10}{3}t - \frac{5}{6}.$$

To find x_{\min} ,

$$\frac{dx}{dt} = -\frac{8}{3}t + \frac{10}{3} = 0$$

$$\text{which gives } t_{\min} = \frac{10}{8} = \frac{5}{4} \text{ s.}$$

$$\text{Therefore, } x_{\min} = -\frac{4}{3}\left(\frac{5}{4}\right)^2 + \frac{10}{3} \times \frac{5}{4} - \frac{5}{6} = \frac{5}{4}.$$

Therefore, $x > 1.25\text{m}$.

Second method: This method does not require the use of calculus.

If the car is behind the truck,

$$V_{\text{car}} = 20 - (20/3)(t - 0.5) \text{ for } t > 0.5 \text{ s as car decelerate only after 0.5 s.}$$

$$V_{\text{truck}} = 20 - 4t$$

Find t from equating the two or from velocity vs time graph. This yields $t = 5/4$ s.

In this time truck would travel truck,

$$S_{\text{truck}} = 20(5/4) - (1/2)(4)(5/4)^2 = 21.875\text{m}$$

and car would travel, $S_{\text{car}} = 20(0.5) + 20(5/4 - 0.5) -$

$$\left(\frac{1}{2}\right)(20/3) \times \left(\frac{5}{4} - 0.5\right)^2 = 23.125\text{m}$$

Thus $S_{\text{car}} - S_{\text{truck}} = 1.25\text{m}$.

If the car maintains this distance initially, its speed after 1.25s will be always less than that of truck and hence collision never occurs.

3.25 (a) $(3/2)\text{s}$, (b) $(9/4)\text{s}$, (c) 0.3s , (d) 6 cycles.

3.26 $v_1 = 20\text{ m/s}$, $v_2 = 10\text{ m/s}$, time difference = 1s.

Chapter 4

4.1 (b)

4.2 (d)

4.3 (b)

4.4 (b)

4.5 (c)

4.6 (b)

4.7 (d)

4.8 (c)

4.9 (c)

4.10 (b)

4.11 (a), (b)

4.12 (c)

4.13 (a), (c)

4.14 (a), (b), (c)

4.15 (b), (d)

4.16 $\frac{v^2}{R}$ in the direction **RO**.

4.17 The students may discuss with their teachers and find answer.

4.18 (a) Just before it hits the ground.

- (b) At the highest point reached.
 (c) $a = g = \text{constant}$.

4.19 acceleration – g .
 velocity – zero.

4.20 Since $\mathbf{B} \times \mathbf{C}$ is perpendicular to plane of \mathbf{B} and \mathbf{C} , cross product of any vector will lie in the plane of \mathbf{B} and \mathbf{C} .

4.21

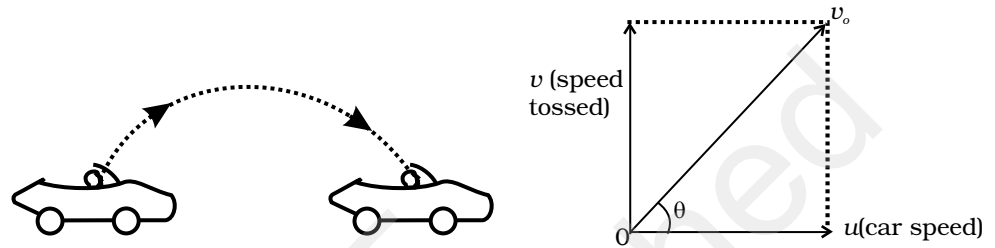

For a ground-based observer, the ball is a projectile with speed v_0 and the angle of projection θ with horizontal in as shown above.

4.22

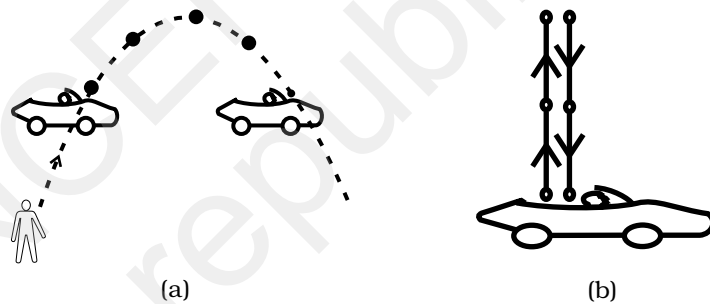

Since the speed of car matches with the horizontal speed of the projectile, boy sitting in the car will see only vertical component of motion as shown in Fig (b).

4.23 Due to air resistance, particle energy as well as horizontal component of velocity keep on decreasing making the fall steeper than rise as shown in the figure.

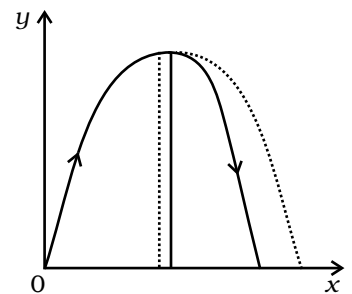

4.24 $R = v_0 \sqrt{\frac{2H}{g}}, \phi = \tan^{-1} \left(\frac{H}{R} \right) = \tan^{-1} \left(\frac{1}{v_0} \sqrt{\frac{gH}{2}} \right) = 23^\circ 12'$

4.25 Acceleration $\frac{v^2}{R} = \frac{4\pi^2 R}{T^2}$

- 4.26** (a) matches with (iv)
 (b) matches with (iii)
 (c) matches with (i)
 (d) matches with (ii)

- 4.27** (a) matches with (ii)
 (b) matches with (i)
 (c) matches with (iv)
 (d) matches with (iii)

- 4.28** (a) matches with (iv)
 (b) matches with (iii)
 (c) matches with (i)
 (d) matches with (ii)

- 4.29** The minimum vertical velocity required for crossing the hill is given by

$$v_{\perp}^2 \geq 2gh = 10,000$$

$$v_{\perp} > 100 \text{ m/s}$$

As cannon can haul packets with a speed of 125m/s, so the maximum value of horizontal velocity, v_{\parallel} will be

$$v_{\parallel} = \sqrt{125^2 - 100^2} = 75 \text{ m/s}$$

The time taken to reach the top of the hill with velocity v_{\perp} is given by

$$\frac{1}{2} gT^2 = h \Rightarrow T = 10 \text{ s.}$$

In 10s the horizontal distance covered = 750 m.

So cannon has to be moved through a distance of 50 m on the ground.

So total time taken (shortest) by the packet to reach ground

$$\text{across the hill} = \frac{50}{2} \text{ s} + 10\text{s} + 10\text{s} = 45 \text{ s.}$$

4.31 (a) $L = \frac{2v_o^2 \sin \beta \cos(\alpha + \beta)}{g \cos^2 \alpha}$

(b) $T = \frac{2v_o \sin \beta}{g \cos \alpha}$

(c) $\beta = \frac{\pi}{4} - \frac{\alpha}{2}$

4.32 $\frac{Av_o^2}{g} \sin \theta$

4.33 $\mathbf{V}_r = 5\hat{i} - 5\hat{j}$

4.34 (a) 5 m/s at 37° to N.

(b) (i) $\tan^{-1}(3/\sqrt{7})$ of N, (ii) $\sqrt{7}$ m/s

(c) in case (i) he reaches the opposite bank in shortest time.

4.35 (a) $\tan^{-1}\left(\frac{v_o \sin \theta}{v_o \cos \theta + u}\right)$

(b) $\frac{2v_o \sin \theta}{g}$

(c) $R = \frac{2v_o \sin \theta (v_o \cos \theta + u)}{g}$

(d) $\theta_{\max} = \cos^{-1}\left[\frac{-u + \sqrt{u^2 + 8v_o^2}}{4v_o}\right]$

(e) $\theta_{\max} = 60^\circ$ for $u = v_o$.

$\theta_{\max} = 45^\circ$ for $u = 0$.

$u < v_o$

$\therefore \theta_{\max} \approx \cos^{-1}\left(\frac{1}{\sqrt{2}} - \frac{u}{4v_o}\right) = \pi/4$ (if $u \ll v_o$)

$u > v_o$ $\theta_{\max} \approx \cos^{-1}\left[\frac{v_o}{u}\right] = \pi/2$ ($v_o \ll u$)

(f) $\theta_{\max} \geq 45^\circ$.

4.36 $\mathbf{V} = \omega \hat{r} + \omega \theta \hat{\theta}$ and $\mathbf{a} = \left(\frac{d^2\theta}{dt^2} - \omega^2 \theta\right) \hat{r} + \left(\theta \frac{d^2\theta}{dt^2} + 2\omega^2\right) \hat{\theta}$

4.37 Consider the straight line path APQC through the sand.

Time taken to go from A to C via this path

$$\begin{aligned} T_{\text{sand}} &= \frac{AP + QC}{1} + \frac{PQ}{v} \\ &= \frac{25\sqrt{2} + 25\sqrt{2}}{1} + \frac{50\sqrt{2}}{v} \\ &= 50\sqrt{2} \left[\frac{1}{v} + 1\right] \end{aligned}$$

The shortest path outside the sand will be ARC.

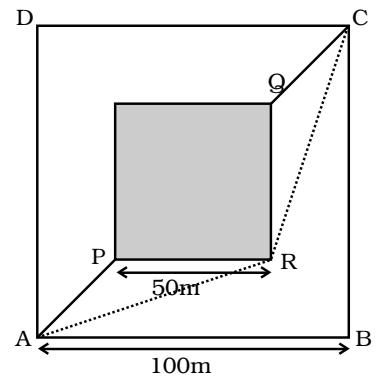

Time taken to go from A to C via this path

$$= T_{\text{outside}} = \frac{AR + RC}{1} \text{ s}$$

$$= 2\sqrt{75^2 + 25^2} \text{ s}$$

$$= 2 \times 25\sqrt{10} \text{ s}$$

$$\text{For } T_{\text{sand}} < T_{\text{outside}}, \quad 50\sqrt{2} \left[\frac{1}{v} + 1 \right] < 2 \times 25\sqrt{10}$$

$$\Rightarrow \frac{1}{v} + 1 < \sqrt{5}$$

$$\Rightarrow \frac{1}{v} < \sqrt{5} - 1 \text{ or } v > \frac{1}{\sqrt{5} - 1} \approx 0.81 \text{ m/s.}$$

Chapter 5

- 5.1 (c)
 5.2 (b)
 5.3 (c)
 5.4 (c)
 5.5 (d)
 5.6 (c)
 5.7 (a)
 5.8 (b)
 5.9 (b)
 5.10 (a), (b) and (d)
 5.11 (a), (b), (d) and (e)
 5.12 (b) and (d)
 5.13 (b), (c)
 5.14 (c), (d)
 5.15 (a), (c)
 5.16 Yes, due to the principle of conservation of momentum.
 Initial momentum = $50.5 \times 5 \text{ kg m s}^{-1}$

$$\text{Final momentum} = (50 v + 0.5 \times 15) \text{ kg m s}^{-1}$$

$$v = 4.9 \text{ m s}^{-1}, \text{ change in speed} = 0.1 \text{ m s}^{-1}$$

5.17 Let R be the reading of the scale, in newtons.

$$\text{Effective downward acceleration} = \frac{50g - R}{50} = g$$

$$R = 5g = 50\text{N. (The weighing scale will show 5 kg).}$$

5.18 Zero; $-\frac{3}{2} \text{ kg m s}^{-1}$

5.19 The only retarding force that acts on him, if he is not using a seat belt comes from the friction exerted by the seat. This is not enough to prevent him from moving forward when the vehicle is brought to a sudden halt.

5.20 $\mathbf{p} = 8\hat{\mathbf{i}} + 8\hat{\mathbf{j}}$, $\mathbf{F} = (4\hat{\mathbf{i}} + 8\hat{\mathbf{j}})\text{N}$

5.21 $f = F$ until the block is stationary.

f remains constant if F increases beyond this point and the block starts moving.

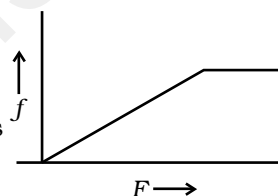

5.22 In transportation, the vehicle say a truck, may need to halt suddenly. To bring a fragile material, like porcelain object to a sudden halt means applying a large force and this is likely to damage the object. If it is wrapped up in say, straw, the object can travel some distance as the straw is soft before coming to a halt. The force needed to achieve this is less, thus reducing the possibility of damage.

5.23 The body of the child is brought to a sudden halt when she/he falls on a cement floor. The mud floor yields and the body travels some distance before it comes to rest, which takes some time. This means the force which brings the child to rest is less for the fall on a mud floor, as the change in momentum is brought about over a longer period.

5.24 (a) 12.5 N s (b) $18.75 \text{ kg m s}^{-1}$

5.25 $f = \mu R = \mu mg \cos\theta$ is the force of friction, if θ is angle made by the slope. If θ is small, force of friction is high and there is less chance of skidding. The road straight up would have a larger slope.

5.26 AB, because force on the upper thread will be equal to sum of the weight of the body and the applied force.

5.27 If the force is large and sudden, thread CD breaks because as CD is jerked, the pull is not transmitted to AB instantaneously (transmission depends on the elastic properties of the body). Therefore, before the mass moves, CD breaks.

5.28 $T_1 = 94.4 \text{ N}$, $T_2 = 35.4 \text{ N}$

5.29 $W = 50 \text{ N}$

5.30 If F is the force of the finger on the book, $F = N$, the normal reaction of the wall on the book. The minimum upward frictional force needed to ensure that the book does not fall is Mg . The frictional force $= \mu N$. Thus, minimum value of $F = \frac{Mg}{\mu}$.

5.31 0.4 m s^{-1}

5.32 $x = t$, $y = t^2$

$$a_x = 0, \quad a_y = 2 \text{ m s}^{-1}$$

$F = 0.5 \times 2 = 1 \text{ N}$. along y -axis.

5.33 $t = \frac{2V}{g+a} = \frac{2 \times 20}{10+2} = \frac{40}{12} = \frac{10}{3} = 3.33 \text{ s}$.

5.34 (a) Since the body is moving with no acceleration, the sum of the forces is zero $\mathbf{F}_1 + \mathbf{F}_2 + \mathbf{F}_3 = 0$. Let $\mathbf{F}_1, \mathbf{F}_2, \mathbf{F}_3$ be the three forces passing through a point. Let \mathbf{F}_1 and \mathbf{F}_2 be in the plane A (one can always draw a plane having two intersecting lines such that the two lines lie on the plane). Then $\mathbf{F}_1 + \mathbf{F}_2$ must be in the plane A. Since $\mathbf{F}_3 = -(\mathbf{F}_1 + \mathbf{F}_2)$, \mathbf{F}_3 is also in the plane A.

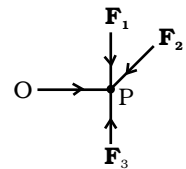

(b) Consider the torque of the forces about P. Since all the forces pass through P, the torque is zero. Now consider torque about another point O. Then torque about O is

$$\text{Torque} = \mathbf{OP} \times (\mathbf{F}_1 + \mathbf{F}_2 + \mathbf{F}_3)$$

Since $\mathbf{F}_1 + \mathbf{F}_2 + \mathbf{F}_3 = 0$, torque = 0

5.35 **General case**

$$s = \frac{1}{2}at^2 \Rightarrow t = \sqrt{2s/a}$$

Smooth case

$$\text{Acceleration } a = g \sin \theta = \frac{g}{\sqrt{2}}$$

$$\therefore t_1 = \sqrt{2\sqrt{2}s/g}$$

Rough case

Acceleration $a = g \sin \theta - \mu g \cos \theta$

$$= (1 - \mu)g / \sqrt{2}$$

$$\therefore t_2 = \sqrt{\frac{2\sqrt{2}s}{(1 - \mu)g}} = pt_1 = p\sqrt{\frac{2\sqrt{2}s}{g}}$$

$$\Rightarrow \frac{1}{1 - \mu} = p^2 \Rightarrow \mu = 1 - \frac{1}{p^2}$$

5.36 $v_x = 2t \quad 0 < t \leq 1 \quad v_y = t \quad 0 < t < 1s$

$$= 2(2 - t) \quad 1 < t < 2 \quad = 11 < t$$

$$= 0 \quad 2 < t$$

$$F_x = 2; \quad 0 < t < 1 \quad F_y = 1 \quad 0 < t < 1s$$

$$= -2; \quad 1s < t < 2s \quad = 0 \quad 1s < t$$

$$= 0; \quad 2s < t$$

$$\mathbf{F} = 2\hat{i} + \hat{j} \quad 0 < t < 1s$$

$$= -2\hat{i} \quad 1s < t < 2s$$

$$= 0 \quad 2s < t$$

5.37 For DEF

$$m \frac{v^2}{R} = m g \mu$$

$$v_{\max} = \sqrt{g\mu R} = \sqrt{100} = 10 \text{ m s}^{-1}$$

For ABC

$$\frac{v^2}{2R} = g\mu, \quad v = \sqrt{200} = 14.14 \text{ m s}^{-1}$$

$$\text{Time for DEF} = \frac{\pi}{2} \times \frac{100}{10} = 5\pi s$$

$$\text{Time for ABC} = \frac{3\pi}{2} \frac{200}{14.14} = \frac{300\pi}{14.14} s$$

$$\text{For FA and DC} = 2 \times \frac{100}{50} = 4s$$

$$\text{Total time} = 5\pi + \frac{300\pi}{14.14} + 4 = 86.3s$$

5.38 $\frac{d\mathbf{r}}{dt} = \mathbf{v} = -\hat{i} \omega A \sin \omega t + \hat{j} \omega B \cos \omega t$

$$\frac{d\mathbf{v}}{dt} = \mathbf{a} = -\omega^2 \mathbf{r}; \quad \mathbf{F} = -m\omega^2 \mathbf{r}$$

$$x = A \cos \omega t, \quad y = B \sin \omega t \Rightarrow \frac{x^2}{A^2} + \frac{y^2}{B^2} = 1$$

5.39 For (a) $\frac{1}{2}v_z^2 = gH$ $v_z = \sqrt{2gH}$

$$\text{Speed at ground} = \sqrt{v_s^2 + v_z^2} = \sqrt{v_s^2 + 2gH}$$

For (b) also $\left[\frac{1}{2}mv_s^2 + mgH \right]$ is the total energy of the ball when it hits the ground.

So the speed would be the same for both (a) and (b).

5.40 $F_2 = \frac{F_3 + F_4}{\sqrt{2}} = \frac{2+1}{\sqrt{2}} = \frac{3}{\sqrt{2}} \text{ N}$

$$F_1 + \frac{F_3}{\sqrt{2}} = \frac{F_4}{\sqrt{2}}$$

$$F_1 = \frac{F_4 - F_3}{\sqrt{2}} = \frac{1}{\sqrt{2}} \text{ N}$$

5.41 (a) $\theta = \tan^{-1} \mu$

(b) $mg \sin \alpha - \mu mg \cos \alpha$

(c) $mg(\sin \alpha + \mu \cos \alpha)$

(d) $mg(\sin \theta + \mu \cos \theta) + ma$.

5.42 (a) $F - (500 \times 10) = (500 \times 15)$ or $F = 12.5 \times 10^3 \text{ N}$, where F is the upward reaction of the floor and is equal to the force downwards on the floor, by Newton's 3rd law of motion

(b) $R - (2500 \times 10) = (2500 \times 15)$ or $R = 6.25 \times 10^4 \text{ N}$, action of the air on the system, upwards. The action of the rotor on the surrounding air is $6.25 \times 10^4 \text{ N}$ downwards.

(c) Force on the helicopter due to the air = $6.25 \times 10^4 \text{ N}$ upwards.

Chapter 6

- 6.1 (b)
- 6.2 (c)
- 6.3 (d)
- 6.4 (c)
- 6.5 (c)
- 6.6 (c)
- 6.7 (c)
- 6.8 (b)
- 6.9 (b)
- 6.10 (b)
- 6.11 (b) as displacement $\propto t^{3/2}$
- 6.12 (d)
- 6.13 (d)
- 6.14 (a)
- 6.15 (b)
- 6.16 (d)
- 6.17 (b)
- 6.18 (c)
- 6.19 (b), (d)
- 6.20 (b), (d), (f)
- 6.21 (c)
- 6.22 Yes, No.
- 6.23 To prevent elevator from falling freely under gravity.
- 6.24 (a) Positive, (b) Negative
- 6.25 Work done against gravity in moving along horizontal road is zero .
- 6.26 No, because resistive force of air also acts on the body which is a non-conservative force. So the gain in KE would be smaller than the loss in PE.
- 6.27 No, work done over each closed path is necessarily zero only if all the forces acting on the system are conservative.

6.28 (b) Total linear momentum.

While balls are in contact, there may be deformation which means elastic potential energy which came from part of KE. Momentum is always conserved.

6.29
$$\text{Power} = \frac{mgh}{T} = \frac{100 \times 9.8 \times 10}{20} \text{ W} = 490 \text{ W}$$

6.30
$$P = \frac{\Delta E}{\Delta t} = \frac{0.5 \times 72}{60} = 0.6 \text{ watts}$$

6.31 A charged particle moving in an uniform magnetic field.

6.32 Work done = change in KE

Both bodies had same KE and hence same amount of work is needed to be done. Since force applied is same, they would come to rest within the same distance.

6.33 (a) Straight line: vertical, downward

(b) Parabolic path with vertex at C.

(c) Parabolic path with vertex higher than C.

6.34

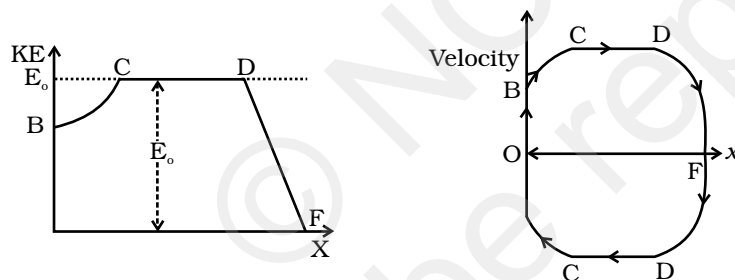

6.35 (a) For head on collision:

Conservation of momentum $\Rightarrow 2mv_0 = mv_1 + mv_2$

Or $2v_0 = v_1 + v_2$

and $e = \frac{v_2 - v_1}{v_0} \Rightarrow v_2 = v_1 + 2v_0e$

$\therefore 2v_1 = 2v_0 - 2ev_0$

$\therefore v_1 = v_0(1 - e)$

Since $e < 1 \Rightarrow v_1$ has the same sign as v_0 , therefore the ball moves on after collision.

(b) Conservation of momentum $\Rightarrow \mathbf{p} = \mathbf{p}_1 + \mathbf{p}_2$

But KE is lost $\Rightarrow \frac{p^2}{2m} > \frac{p_1^2}{2m} + \frac{p_2^2}{2m}$

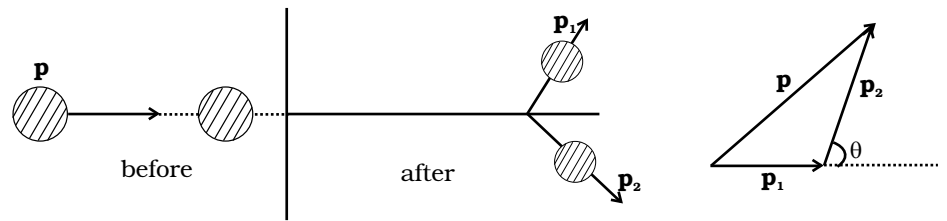

$$\therefore p^2 > p_1^2 + p_2^2$$

Thus \mathbf{p} , \mathbf{p}_1 and \mathbf{p}_2 are related as shown in the figure.

θ is acute (less than 90°) ($p^2 = p_1^2 + p_2^2$ would give $\theta = 90^\circ$)

6.36 Region A : No, as KE will become negative.

Region B : Yes, total energy can be greater than PE for non zero K.E.

Region C : Yes, KE can be greater than total energy if its PE is negative.

Region D : Yes, as PE can be greater than KE.

6.37 (a) Ball A transfers its entire momentum to the ball on the table and does not rise at all.

(b) $v = \sqrt{2gh} = 4.42 \text{ m/s}$

6.38 (a) Loss of PE = $mgh = 1 \times 10^{-3} \times 10 \times 10^{-3} = 10 \text{ J}$

(b) Gain in KE = $\frac{1}{2}mv^2 = \frac{1}{2} \times 10^{-3} \times 2500 = 1.25 \text{ J}$

(c) No, because a part of PE is used up in doing work against the viscous drag of air.

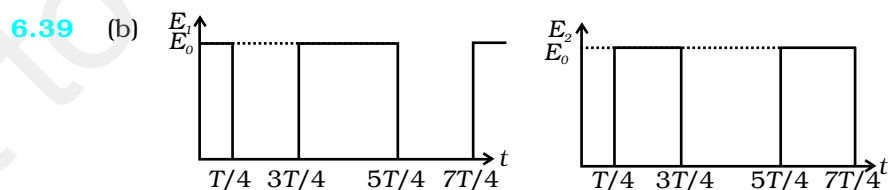

6.40 $m = 3.0 \times 10^{-5} \text{ kg}$ $\rho = 10^{-3} \text{ kg/m}^2$ $v = 9 \text{ m/s}$

$A = 1 \text{ m}^2$ $h = 100 \text{ cm} \Rightarrow n = 1 \text{ m}^3$

$M = \rho v = 10^{-3} \text{ kg}$, $E = \frac{1}{2}Mv^2 = \frac{1}{2} \times 10^{-3} \times (9)^2 = 4.05 \times 10^{-4} \text{ J}$.

6.41 $KE = \frac{1}{2}mv^2 \cong \frac{1}{2} \times 5 \times 10^4 \times 10^2$
 $= 2.5 \times 10^5 \text{ J.}$

10% of this is stored in the spring.

$$\frac{1}{2}kx^2 = 2.5 \times 10^4$$

$$x = 1 \text{ m}$$

$$k = 5 \times 10^4 \text{ N/m.}$$

6.42 In 6 km there are 6000 steps.

$$\begin{aligned} \therefore E &= 6000 (mgh) \\ &= 6000 \times 600 \times 0.25 \\ &= 9 \times 10^5 \text{ J.} \end{aligned}$$

This is 10 % of intake.

$$\therefore \text{Intake energy} = 10 E = 9 \times 10^6 \text{ J.}$$

6.43 With 0.5 efficiency, 1 litre generates $1.5 \times 10^7 \text{ J}$, which is used for 15 km drive.

$$\therefore Fd = 1.5 \times 10^7 \text{ J. with } d = 15000 \text{ m}$$

$$\therefore F = 1000 \text{ N : force of friction.}$$

6.44 (a) $W_g = mg \sin \theta d = 1 \times 10 \times 0.5 \times 10 = 50 \text{ J.}$

(b) $W_f = \mu mg \cos \theta d = 0.1 \times 10 \times 0.866 \times 10 = 8.66 \text{ J.}$

(c) $\Delta U = mgh = 1 \times 10 \times 5 = 50 \text{ J}$

(d) $\alpha = \{F - (mg \sin \theta + \mu mg \cos \theta)\} = [10 - 5.87]$

$$= 4.13 \text{ m/s}^2$$

$$v = u + at \text{ or } v^2 = u^2 + 2ad$$

$$\Delta K = \frac{1}{2}mv^2 - \frac{1}{2}mu^2 = mad = 41.3 \text{ J}$$

(e) $W = Fd = 100 \text{ J}$

6.45 (a) Energy is conserved for balls 1 and 3.

(b) Ball 1 acquires rotational energy, ball 2 loses energy by friction.

They cannot cross at C. Ball 3 can cross over.

- (c) Ball 1, 2 turn back before reaching C. Because of loss of energy, ball 2 cannot reach back to A. Ball 1 has a rotational motion in “wrong” sense when it reaches B. It cannot roll back to A, because of kinetic friction.

$$\begin{aligned}
 6.46 \quad (KE)_{t+\Delta t} &= \frac{1}{2}(M - \Delta m)(v + \Delta v)^2 + \frac{1}{2}\Delta m(v - u)^2 \\
 &= \frac{1}{2}Mv^2 + Mv\Delta v - \Delta mvu + \frac{1}{2}\Delta mu^2 \\
 (KE)_t &= \frac{1}{2}Mv^2
 \end{aligned}$$

$$(KE)_{t+\Delta t} - (KE)_t = (M\Delta v - \Delta mu)v + \frac{1}{2}\Delta mu^2 = \frac{1}{2}\Delta mu^2 = W$$

(By Work - Energy theorem)

$$\text{Since } \left(\frac{Mdv}{dt} = \left(\frac{dm}{dt} \right) (|u|) \right) \Rightarrow (M\Delta v - \Delta mu) = 0$$

$$6.47 \quad \text{Hooke's law : } \frac{F}{A} = Y \frac{\Delta L}{L}$$

where A is the surface area and L is length of the side of the cube. If k is spring or compression constant, then $F = k \Delta L$

$$\therefore k = Y \frac{A}{L} = YL$$

$$\text{Initial KE} = 2 \times \frac{1}{2}mv^2 = 5 \times 10^{-4} \text{ J}$$

$$\text{Final PE} = 2 \times \frac{1}{2}k(\Delta L)^2$$

$$\therefore \Delta L = \sqrt{\frac{KE}{k}} = \sqrt{\frac{KE}{YL}} = \sqrt{\frac{5 \times 10^{-4}}{2 \times 10^{11} \times 0.1}} = 1.58 \times 10^{-7} \text{ m}$$

- 6.48 Let m , V , ρ_{He} denote respectively the mass, volume and density of helium balloon and ρ_{air} be density of air

Volume V of balloon displaces volume V of air.

$$\text{So, } V(\rho_{air} - \rho_{He})g = ma \quad (1)$$

Integrating with respect to t ,

$$V(\rho_{air} - \rho_{He})gt = mv$$

$$\Rightarrow \frac{1}{2}mv^2 = \frac{1}{2}m \frac{V^2}{m^2} (\rho_{air} - \rho_{He})^2 g^2 t^2 = \frac{1}{2m} V^2 (\rho_{air} - \rho_{He})^2 g^2 t^2 \quad (2)$$

If the balloon rises to a height h , from $s = ut + \frac{1}{2}at^2$,

$$\text{we get } h = \frac{1}{2}at^2 = \frac{1}{2} \frac{V(\rho_{\text{air}} - \rho_{\text{He}})}{m} gt^2 \quad (3)$$

From Eqs. (3) and (2),

$$\begin{aligned} \frac{1}{2}mv^2 &= [V(\rho_a - \rho_{\text{He}})g] \left[\frac{1}{2m} V(\rho_a - \rho_{\text{He}}) gt^2 \right] \\ &= V(\rho_a - \rho_{\text{He}})gh \end{aligned}$$

Rearranging the terms,

$$\begin{aligned} \Rightarrow \frac{1}{2}mv^2 + V\rho_{\text{He}}gh &= V\rho_{\text{air}}hg \\ \Rightarrow KE_{\text{balloon}} + PE_{\text{balloon}} &= \text{change in PE of air.} \end{aligned}$$

So, as the balloon goes up, an equal volume of air comes down, increase in PE and KE of the balloon is at the cost of PE of air [which comes down].

Chapter 7

7.1 (d)

7.2 (c)

7.3 The initial velocity is $\mathbf{v}_i = v\hat{\mathbf{e}}_y$ and, after reflection from the wall, the final velocity is $\mathbf{v}_f = -v\hat{\mathbf{e}}_y$. The trajectory is described as $\mathbf{r} = y\hat{\mathbf{e}}_y + a\hat{\mathbf{e}}_z$. Hence the change in angular momentum is $\mathbf{r} \times m(\mathbf{v}_f - \mathbf{v}_i) = 2mva\hat{\mathbf{e}}_x$. Hence the answer is (b).

7.4 (d)

7.5 (b)

7.6 (c)

7.7 When $b \rightarrow 0$, the density becomes uniform and hence the centre of mass is at $x = 0.5$. Only option (a) tends to 0.5 as $b \rightarrow 0$.

7.8 (b) ω

7.9 (a), (c)

7.10 (a), (d)

7.11 All are true.

- 7.12** (a) False, it is along $\hat{\mathbf{k}}$.
 (b) True
 (c) True
 (d) False, there is no sense in adding torques about 2 different axes.
- 7.13** (a) False, perpendicular axis theorem is applicable only to a lamina.
 (b) True
 (c) False, z and z'' are not parallel axes.
 (d) True.
- 7.14** When the vertical height of the object is very small as compared to earth's radius, we call the object small, otherwise it is extended.
 (a) Building and pond are small objects.
 (b) A deep lake and a mountain are examples of extended objects.
- 7.15** $I = \sum m_i r_i^2$. All the mass in a cylinder lies at distance R from the axis of symmetry but most of the mass of a solid sphere lies at a smaller distance than R .
- 7.16** Positive slope indicates anticlockwise rotation which is traditionally taken as positive.
- 7.17** (a) ii, (b) iii, (c) i, (d) iv
- 7.18** (a) iii, (b) iv (c) ii (d) i.
- 7.19** No. Given $\sum_i \mathbf{F}_i \neq 0$
 The sum of torques about a certain point 'O'

$$\sum_i \mathbf{r}_i \times \mathbf{F}_i = 0$$

 The sum of torques about any other point O',

$$\sum_i (\mathbf{r}_i - \mathbf{a}) \times \mathbf{F}_i = \sum_i \mathbf{r}_i \times \mathbf{F}_i - \mathbf{a} \times \sum_i F_i$$

 Here, the second term need not vanish.
- 7.20** The centripetal acceleration in a wheel arise due to the internal elastic forces which in pairs cancel each other; being part of a symmetrical system.

In a half wheel the distribution of mass about its centre of mass (axis of rotation) is not symmetrical. Therefore, the direction of angular momentum does not coincide with the direction of angular velocity and hence an external torque is required to maintain rotation.

7.21 No. A force can produce torque only along a direction normal to itself as $\boldsymbol{\tau} = \mathbf{r} \times \mathbf{f}$. So, when the door is in the xy -plane, the torque produced by gravity can only be along $\pm z$ direction, never about an axis passing through y direction.

7.22 Let the C.M. be 'b'. Then, $\frac{(n-1)mb + ma}{mn} = 0 \Rightarrow b = -\frac{1}{n-1}a$

7.23 (a) Surface density $\sigma = \frac{2M}{\pi a^2}$

$$\begin{aligned} \bar{x} &= \frac{\int x dm}{\int dm} = \frac{a}{r=0} \int_0^\pi r \cos \theta \sigma r dr d\theta = \frac{a}{r=0} \int_0^\pi \sigma r dr d\theta \\ &= \frac{\int_0^a r^2 dr \int_0^\pi \sin \theta d\theta}{\int_0^a r dr \int_0^\pi d\theta} = 0 \end{aligned}$$

$$\begin{aligned} \bar{y} &= \frac{\int y dm}{\int dm} = \frac{\int_0^\pi \int_0^a r \sin \theta \sigma r dr d\theta}{\int_0^\pi \int_0^a \sigma r dr d\theta} \\ &= \frac{\int_0^a r^2 dr \int_0^\pi \sin \theta d\theta}{\int_0^a r dr \int_0^\pi d\theta} = \frac{a^3 [-\cos \theta]_0^\pi}{3 (a^2/2) \pi} = \frac{a \cdot 4}{3 \pi} = \frac{4a}{3\pi} \end{aligned}$$

(b) Same procedure, as in (a) except θ goes from 0 to $\pi/2$ and

$$\sigma = \frac{4M}{\pi a^2} .$$

7.24 (a) Yes, because there is no net external torque on the system. External forces, gravitation and normal reaction, act through the axis of rotation, hence produce no torque.

(b) By angular momentum conservation

$$I\omega = I_1\omega_1 + I_2\omega_2$$

$$\therefore \omega = \frac{I_1\omega_1 + I_2\omega_2}{I_1 + I_2}$$

$$(c) K_f = \frac{1}{2} (I_1 + I_2) \frac{(I_1 \omega_1 + I_2 \omega_2)^2}{(I_1 + I_2)^2} = \frac{1}{2} \frac{(I_1 \omega_1 + I_2 \omega_2)^2}{I_1 + I_2}$$

$$K_i = \frac{1}{2} (I_1 \omega_1^2 + I_2 \omega_2^2)$$

$$\Delta K = K_f - K_i = -\frac{I_1 I_2}{2(I_1 + I_2)} (\omega_1 - \omega_2)^2$$

(d) The loss in kinetic energy is due to the work against the friction between the two discs.

7.25 (a) Zero (b) Decreases (c) Increases (d) Friction (e) $v_{cm} = R\omega$.

(f) Acceleration produced in centre of mass due to friction:

$$a_{cm} = \frac{F}{m} = \frac{\mu_k mg}{m} = \mu_k g.$$

Angular acceleration produced by the torque due to friction,

$$\alpha = \frac{\tau}{I} = \frac{\mu_k mgR}{I}$$

$$\therefore v_{cm} = u_{cm} + a_{cm}t \Rightarrow v_{cm} = \mu_k gt$$

$$\text{and } \omega = \omega_o + \alpha t \Rightarrow \omega = \omega_o - \frac{\mu_k mgR}{I} t$$

For rolling without slipping,

$$\frac{v_{cm}}{R} = \omega_o - \frac{\mu_k mgR}{I} t$$

$$\frac{\mu_k gt}{R} = \omega_o - \frac{\mu_k mgR}{I} t$$

$$t = \frac{R\omega_o}{\mu_k g \left(1 + \frac{mR^2}{I}\right)}$$

7.26 (a)

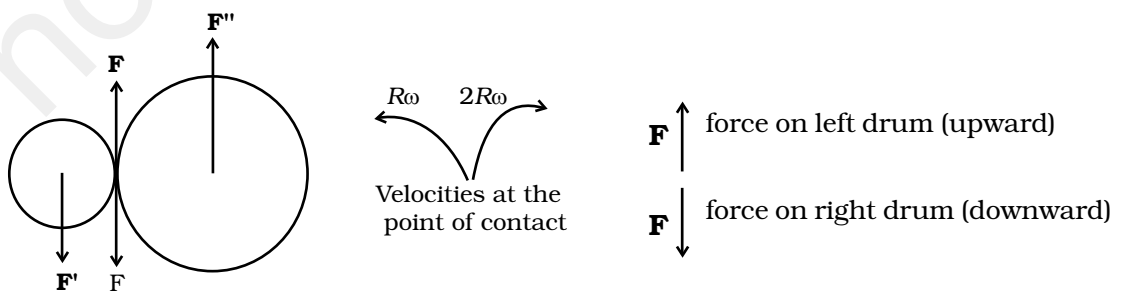

(b) $F' = F = F''$ where F and F'' and external forces through support.

$$F_{\text{net}} = 0$$

External torque = $F \times 3R$, anticlockwise.

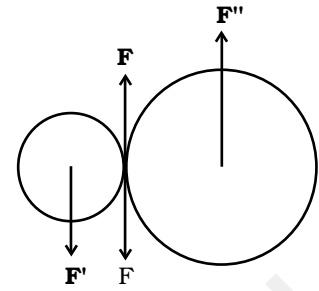

(c) Let ω_1 and ω_2 be final angular velocities (anticlockwise and clockwise respectively)

Finally there will be no friction.

$$\text{Hence, } R \omega_1 = 2 R \omega_2 \Rightarrow \frac{\omega_1}{\omega_2} = 2$$

7.27 (i) Area of square = area of rectangle $\Rightarrow c^2 = ab$

$$\frac{I_{xR}}{I_{xS}} \times \frac{I_{yR}}{I_{yS}} = \frac{b^2}{c^2} \times \frac{a^2}{c^2} = \left(\frac{ab}{c^2}\right)^2 = 1$$

(i) and (ii) $\frac{I_{yR}}{I_{yS}} > \frac{I_{xR}}{I_{xS}} \Rightarrow \frac{I_{yR}}{I_{yS}} > 1$

$$\text{and } \frac{I_{xR}}{I_{xS}} < 1.$$

$$\begin{aligned} \text{(iii) } I_{zR} - I_{zS} &\propto (a^2 + b^2 - 2c^2) \\ &= a^2 + b^2 - 2ab > 0 \end{aligned}$$

$$\therefore (I_{zR} - I_{zS}) > 0$$

$$\therefore \frac{I_{zR}}{I_{zS}} > 1.$$

7.28 Let the acceleration of the centre of mass of disc be 'a', then

$$Ma = F - f \tag{1}$$

The angular acceleration of the disc is $\alpha = a/R$. (if there is no sliding).

Then

$$\left(\frac{1}{2}MR^2\right)\alpha = Rf \tag{2}$$

$$\Rightarrow Ma = 2f$$

Thus, $f = F/3$. Since there is no sliding,

$$\Rightarrow f \leq \mu mg$$

$$\Rightarrow F \leq 3\mu Mg.$$

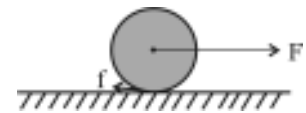

Chapter 8

- 8.1 (d)
- 8.2 (c)
- 8.3 (a)
- 8.4 (c)
- 8.5 (b)
- 8.6 (d)
- 8.7 (d)
- 8.8 (c)
- 8.9 (a), (c)
- 8.10 (a), (c)
- 8.11 (a), (c), (d)
- 8.12 (c), (d)
- 8.13 (c), (d)
- 8.14 (a), (c), (d)
- 8.15 (a), (c)
- 8.16 (d)

8.17 Molecules experience the vertically downward force due to gravity just like an apple falling from a tree. Due to thermal motion, which is random, their velocity is not in the vertical direction. The downward force of gravity causes the density of air in the atmosphere close to earth higher than the density as we go up.

8.18 Central force; gravitational force of a point mass, electrostatic force due to a point charge.

Non-central force: spin-dependent nuclear forces, magnetic force between two current carrying loops.

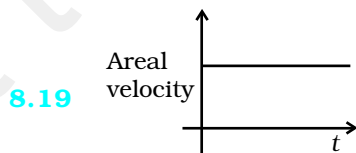

8.20 It is normal to the plane containing the earth and the sun as areal velocity

$$\frac{\Delta \mathbf{A}}{\Delta t} = \frac{1}{2} \mathbf{r} \times \mathbf{v} \Delta t.$$

- 8.21** It remains same as the gravitational force is independent of the medium separating the masses.
- 8.22** Yes, a body will always have mass but the gravitational force on it can be zero; for example, when it is kept at the centre of the earth.
- 8.23** No.
- 8.24** Yes, if the size of the spaceship is large enough for him to detect the variation in g .

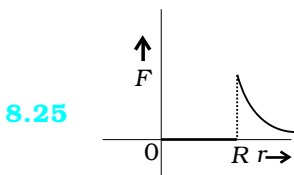

- 8.26** At perihelion because the earth has to cover greater linear distance to keep the areal velocity constant.
- 8.27** (a) 90° (b) 0°
- 8.28** Every day the earth advances in the orbit by approximately 1° . Then, it will have to rotate by 361° (which we define as 1 day) to have sun at zenith point again. Since 361° corresponds to 24 hours; extra 1° corresponds to approximately 4 minute [3 min 59 seconds].

- 8.29** Consider moving the mass at the middle by a small amount h to the right. Then the forces on it are: $\frac{GMm}{(R-h)^2}$ to the

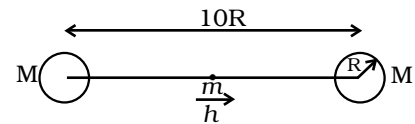

right and $\frac{GMm}{(R+h)^2}$ to the left. The first is larger than the second. Hence the net force will also be towards the right. Hence the equilibrium is unstable.

8.30

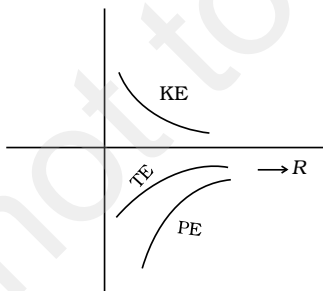

- 8.31** The trajectory of a particle under gravitational force of the earth will be a conic section (for motion outside the earth) with the centre of the earth as a focus. Only (c) meets this requirement.

8.32 $mgR/2$.

8.33 Only the horizontal component (i.e. along the line joining m and O) will survive. The horizontal component of the force on any point on the ring changes by a factor:

$$\left[\frac{2r}{(4r^2 + r^2)^{3/2}} \right] \left[\frac{\mu}{(r^2 + r^2)^{3/2}} \right]$$

$$= \frac{4\sqrt{2}}{5\sqrt{5}}.$$

8.34 As r increases:

$$U \left(= -\frac{GMm}{r} \right) \text{ increases.}$$

$$v_c \left(= \sqrt{\frac{GM}{r}} \right) \text{ decreases.}$$

$$\omega \left(= \frac{v_c}{r} \times \frac{1}{r^{3/2}} \right) \text{ decreases.}$$

K decreases because v increases.

E increases because $|U| = 2K$ and $U < 0$

l increases because $mvr \propto \sqrt{r}$.

8.35 $AB = C$

$$(AC) = 2 AG = 2.l \cdot \frac{\sqrt{3}}{2} = \sqrt{3}l$$

$$AD = AH + HJ + JD$$

$$= \frac{l}{2} + l + \frac{l}{2}$$

$$= 2l.$$

$$AE = AC = \sqrt{3}l, \quad AF = l$$

Force along AD due to m at F and B

$$= Gm^2 \left[\frac{1}{l^2} \right] \frac{1}{2} + Gm^2 \left[\frac{1}{l^2} \right] \frac{1}{2} = \frac{Gm^2}{l^2}$$

Force along AD due to masses at E and C

$$= Gm^2 \frac{1}{3l^2} \cos(30^\circ) + \frac{Gm^2}{3l^2} \cos(30^\circ)$$

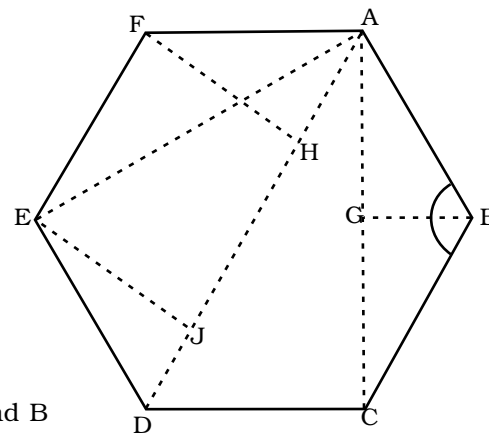

$$= \frac{Gm^2}{3l^2} \sqrt{3} = \frac{Gm^2}{\sqrt{3}l^2}.$$

Force due to mass M at D

$$= \frac{Gm^2}{4l^2}.$$

$$\therefore \text{Total Force} = \frac{Gm^2}{l^2} \left[1 + \frac{1}{\sqrt{3}} + \frac{1}{4} \right].$$

8.36 (a) $r = \left(\frac{GMT^2}{4\pi^2} \right)^{1/3}$

$$\begin{aligned} \therefore h &= \left(\frac{GMT^2}{4\pi^2} \right)^{1/3} - R \\ &= 4.23 \times 10^7 - 6.4 \times 10^6 \\ &= 3.59 \times 10^7 \text{ m.} \end{aligned}$$

(b) $\theta = \cos^{-1} \left(\frac{R}{R+h} \right)$

$$= \cos^{-1} \left(\frac{1}{1+h/r} \right)$$

$$= \cos^{-1} \left(\frac{1}{1+5.61} \right)$$

$$= 81^\circ 18'$$

$$\therefore 2\theta = 162^\circ 36'$$

$$\frac{360^\circ}{2\theta} \approx 2.21; \text{ Hence minimum number} = 3.$$

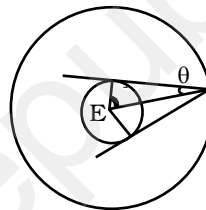

8.37 Angular momentum and areal velocity are constant as earth orbits the sun.

At perigee $r_p^2 \omega_p = r_a^2 \omega_a$ at apogee.

If ' a ' is the semi-major axis of earth's orbit, then $r_p = a(1 - e)$ and

$$r_a = a(1 + e).$$

$$\therefore \frac{\omega_p}{\omega_a} = \left(\frac{1+e}{1-e} \right)^2, \quad e = 0.0167$$

$$\therefore \frac{\omega_p}{\omega_a} = 1.0691$$

Let ω be angular speed which is geometric mean of ω_p and ω_a and corresponds to mean solar day,

$$\therefore \left(\frac{\omega_p}{\omega}\right)\left(\frac{\omega}{\omega_a}\right) = 1.0691$$

$$\therefore \frac{\omega_p}{\omega} = \frac{\omega}{\omega_a} = 1.034.$$

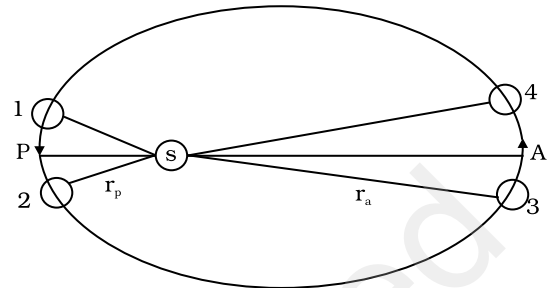

If ω corresponds to 1° per day (mean angular speed), then

$\omega_p = 1.034^\circ$ per day and $\omega_a = 0.967^\circ$ per day. Since $361^\circ = 14$ hrs: mean solar day, we get 361.034° which corresponds to 24 hrs 8.14" (8.1" longer) and 360.967° corresponds to 23 hrs 59 min 52" (7.9" smaller).

This does not explain the actual variation of the length of the day during the year.

8.38 $r_a = a(1 + e) = 6R$
 $r_p = a(1 - e) = 2R \Rightarrow e = \frac{1}{2}$

Conservation of angular momentum:

angular momentum at perigee = angular momentum at apogee

$$\therefore m v_p r_p = m v_a r_a$$

$$\therefore \frac{v_a}{v_p} = \frac{1}{3}.$$

Conservation of Energy:

Energy at perigee = Energy at apogee

$$\frac{1}{2} m v_p^2 - \frac{GMm}{r_p} = \frac{1}{2} m v_a^2 - \frac{GMm}{r_a}$$

$$\therefore v_p^2 \left(1 - \frac{1}{9}\right) = -2GM \left[\frac{1}{r_a} - \frac{1}{r_p}\right] = 2GM \left[\frac{1}{r_a} - \frac{1}{r_p}\right]$$

$$v_p = \frac{2GM \left[\frac{1}{r_p} - \frac{1}{r_a}\right]^{1/2}}{\left[1 - \left(\frac{v_a}{v_p}\right)\right]^2} = \left[\frac{2GM \left[\frac{1}{2} - \frac{1}{6}\right]}{\left(1 - \frac{1}{9}\right)}\right]^{1/2}$$

$$= \left(\frac{2/3 GM}{8/9 R} \right)^{1/2} = \sqrt{\frac{3 GM}{4 R}} = 6.85 \text{ km/s}$$

$$v_p = 6.85 \text{ km/s}, \quad v_a = 2.28 \text{ km/s}.$$

$$\text{For } r = 6R, \quad v_c = \sqrt{\frac{GM}{6R}} = 3.23 \text{ km/s}.$$

Hence to transfer to a circular orbit at apogee, we have to boost the velocity by $\Delta = (3.23 - 2.28) = 0.95 \text{ km/s}$. This can be done by suitably firing rockets from the satellite.

Chapter 9

- 9.1 (b)
 9.2 (d)
 9.3 (d)
 9.4 (c)
 9.5 (b)
 9.6 (a)
 9.7 (c)
 9.8 (d)
 9.9 (c), (d)
 9.10 (a), (d)
 9.11 (b), (d)
 9.12 (a), (d)
 9.13 (a), (d)
 9.14 Steel
 9.15 No
 9.16 Copper
 9.17 Infinite
 9.18 Infinite

9.19 Let Y be the Young's modulus of the material. Then

$$Y = \frac{f / \pi r^2}{l / L}$$

Let the increase in length of the second wire be l' . Then

$$\frac{\frac{2f}{4\pi r^2}}{l' / 2L} = Y$$

$$\text{Or, } l' = \frac{1}{Y} \frac{2f}{4\pi r^2} 2L = \frac{l}{L} \frac{\pi r^2}{f} \times \frac{2f}{4\pi r^2} 2L = l$$

9.20 Because of the increase in temperature the increase in length per unit length of the rod is

$$\frac{\Delta l}{l_0} = \alpha \Delta T = 10^{-5} \times 2 \times 10^{-2} = 2 \times 10^{-3}$$

Let the compressive tension on the rod be T and the cross sectional area be a , then

$$\frac{T/a}{\Delta l / l_0} = Y$$

$$\begin{aligned} \therefore T &= Y \frac{\Delta l}{l_0} \times a = 2 \times 10^{11} \times 2 \times 10^{-3} \times 10^{-4} \\ &= 4 \times 10^4 \text{ N} \end{aligned}$$

9.21 Let the depth be h , then the pressure is

$$P = \rho gh = 10^3 \times 9.8 \times h$$

$$\text{Now } \left| \frac{P}{\Delta V / V} \right| = B$$

$$\therefore P = B \frac{\Delta V}{V} = 9.8 \times 10^8 \times 0.1 \times 10^{-2}$$

$$\therefore h = \frac{9.8 \times 10^8 \times 0.1 \times 10^{-2}}{9.8 \times 10^3} = 10^2 \text{ m}$$

9.22 Let the increase in length be Δl , then

$$\frac{800}{(\pi \times 25 \times 10^{-6}) / (\Delta l / 9.1)} = 2 \times 10^{11}$$

$$\begin{aligned} \therefore \Delta l &= \frac{9.1 \times 800}{\pi \times 25 \times 10^{-6} \times 2 \times 10^{11}} \text{ m} \\ &\approx 0.5 \times 10^{-3} \text{ m} \end{aligned}$$

9.23 As the ivory ball is more elastic than the wet-clay ball, it will tend to retain its shape instantaneously after the collision. Hence, there will be a large energy and momentum transfer compared to the wet clay ball. Thus, the ivory ball will rise higher after the collision.

9.24 Let the cross sectional area of the bar be A . Consider the equilibrium of the plane aa' . A force \mathbf{F} must be acting on this plane making an angle $\frac{\pi}{2} - \theta$ with the normal ON . Resolving \mathbf{F} into components, along the plane and normal to the plane

$$F_p = F \cos \theta$$

$$F_N = F \sin \theta$$

Let the area of the face aa' be A' , then

$$\frac{A}{A'} = \sin \theta$$

$$\therefore A' = \frac{A}{\sin \theta}$$

The tensile stress $T = \frac{F \sin \theta}{A'} = \frac{F}{A} \sin^2 \theta$ and the shearing stress $Z = \frac{F \cos \theta}{A'} = \frac{F}{A} \cos \theta \sin \theta = \frac{F \sin 2\theta}{2A}$. Maximum tensile stress is when $\theta = \frac{\pi}{2}$ and maximum shearing stress when $2\theta = \frac{\pi}{2}$ or $\theta = \frac{\pi}{4}$.

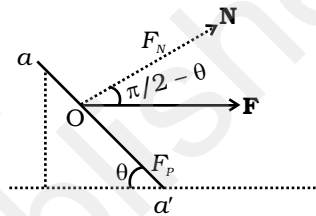

9.25 (a) Consider an element dx at a distance x from the load ($x = 0$). If $T(x)$ and $T(x + dx)$ are tensions on the two cross sections a distance dx apart, then

$$T(x + dx) - T(x) = \mu g dx \text{ (where } \mu \text{ is the mass/length)}$$

$$\frac{dT}{dx} dx = \mu g dx$$

$$\Rightarrow T(x) = \mu g x + C$$

$$\text{At } x = 0, T(0) = Mg \Rightarrow C = Mg$$

$$\therefore T(x) = \mu g x + Mg$$

Let the length dx at x increase by dr , then

$$\frac{T(x)/A}{dr/dx} = Y$$

$$\text{or, } \frac{dr}{dx} = \frac{1}{YA} T(x)$$

$$\Rightarrow r = \frac{1}{YA} \int_0^L (\mu gx + Mg) dx$$

$$= \frac{1}{YA} \left[\frac{\mu gx^2}{2} + Mgx \right]_0^L$$

$$= \frac{1}{YA} \left[\frac{mgl}{2} + MgL \right]$$

(m is the mass of the wire)

$$A = \pi \times (10^{-3})^2 \text{ m}^2, Y = 200 \times 10^9 \text{ Nm}^{-2}$$

$$m = \pi \times (10^{-3})^2 \times 10 \times 7860 \text{ kg}$$

$$\therefore r = \frac{1}{2 \times 10^{11} \times \pi \times 10^{-6}} \left[\frac{\pi \times 786 \times 10^{-7} \times 10 \times 10}{2} + 25 \times 10 \times 10 \right]$$

$$= [196.5 \times 10^{-6} + 3.98 \times 10^{-3}] \sim 4 \times 10^{-3} \text{ m}$$

(b) The maximum tension would be at $x = L$.

$$T = \mu gL + Mg = (m + M)g$$

The yield force

$$= 250 \times 10^6 \times \pi \times (10^{-3})^2 = 250 \times \pi \text{ N}$$

At yield

$$(m + M)g = 250 \times \pi$$

$$m = \pi \times (10^{-3})^2 \times 10 \times 7860 \ll M \therefore Mg \sim 250 \times \pi$$

$$\text{Hence, } M = \frac{250 \times \pi}{10} = 25 \times \pi \sim 75 \text{ kg.}$$

9.26 Consider an element at r of width dr . Let $T(r)$ and $T(r+dr)$ be the tensions at the two edges.

$$-T(r+dr) + T(r) = \mu \omega^2 r dr \text{ where } \mu \text{ is the mass/length}$$

$$-\frac{dT}{dr} dr = \mu \omega^2 r dr$$

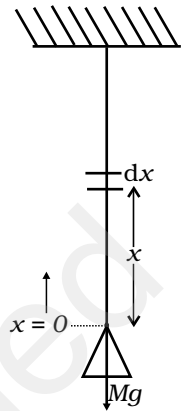

At $r = l$ $T = 0$

$$\Rightarrow C = \frac{\mu\omega^2 l^2}{2}$$

$$\therefore T(r) = \frac{\mu\omega^2}{2} (l^2 - r^2)$$

Let the increase in length of the element dr be $d(\delta)$

$$Y = \frac{(\mu\omega^2/2)(l^2 - r^2)/A}{\frac{d(\delta)}{dr}}$$

$$\therefore \frac{d(\delta)}{dr} = \frac{1}{YA} \frac{\mu\omega^2}{2} (l^2 - r^2)$$

$$\therefore d(\delta) = \frac{1}{YA} \frac{\mu\omega^2}{2} (l^2 - r^2) dr$$

$$\therefore \delta = \frac{1}{YA} \frac{\mu\omega^2}{2} \int_0^l (l^2 - r^2) dr$$

$$= \frac{1}{YA} \frac{\mu\omega^2}{2} \left[l^3 - \frac{r^3}{3} \right] = \frac{1}{3YA} \mu\omega^2 l^3 = \frac{1}{3YA} \mu\omega^2 l^2$$

The total change in length is $2\delta = \frac{2}{3YA} \mu\omega^2 l^2$

9.27 Let $l_1 = AB$, $l_2 = AC$, $l_3 = BC$

$$\cos \theta = \frac{l_3^2 + l_1^2 - l_2^2}{2l_3 l_1}$$

$$\text{Or, } 2l_3 l_1 \cos \theta = l_3^2 + l_1^2 - l_2^2$$

Differentiating

$$2(l_3 dl_1 + l_1 dl_3) \cos \theta - 2l_1 l_3 \sin \theta d\theta$$

$$= 2l_3 dl_3 + 2l_1 dl_3 + 2l_1 \alpha_1 - 2l_2 \alpha_2$$

$$\text{Now, } dl_1 = l_1 \alpha_1 \Delta t$$

$$dl_2 = l_2 \alpha_2 \Delta t$$

$$dl_3 = l_3 \alpha_3 \Delta t$$

$$\text{and } l_1 = l_2 = l_3 = l$$

$$(l^2 \alpha_1 \Delta t + l^2 \alpha_3 \Delta t) \cos \theta + l^2 \sin \theta d\theta = l^2 \alpha_1 \Delta t + l^2 \alpha_3 \Delta t - l^2 \alpha_2 \Delta t$$

$$\sin \theta d\theta = 2\alpha_1 \Delta t (1 - \cos \theta) - \alpha_2 \Delta t$$

Putting $\theta = 60^\circ$

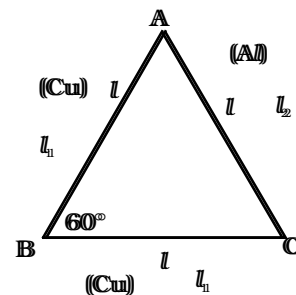
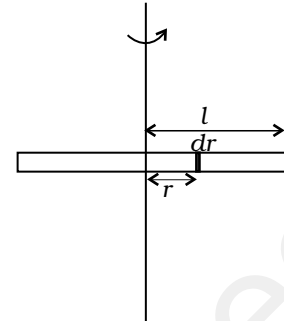

$$d\theta \frac{\sqrt{3}}{2} = 2\alpha_1 \Delta t \times (1/2) - \alpha_2 \Delta t$$

$$= (\alpha_1 - \alpha_2) \Delta t$$

$$\text{Or, } d\theta = \frac{2(\alpha_1 - \alpha_2) \Delta t}{\sqrt{3}}$$

9.28 When the tree is about to buckle

$$Wd = \frac{Y\pi r^4}{4R}$$

If $R \gg h$, then the centre of gravity is at a height $l = \frac{1}{2}h$ from the ground.

From $\triangle ABC$

$$R^2 = (R-d)^2 + \left(\frac{1}{2}h\right)^2$$

If $d \ll R$

$$R^2 \approx R^2 - 2Rd + \frac{1}{4}h^2$$

$$\therefore d = \frac{h^2}{8R}$$

If w_0 is the weight/volume

$$\frac{Y\pi r^4}{4R} = w_0(\pi r^2 h) \frac{h^2}{8R}$$

$$\Rightarrow h = \left(\frac{2Y}{w_0}\right)^{1/3} r^{2/3}$$

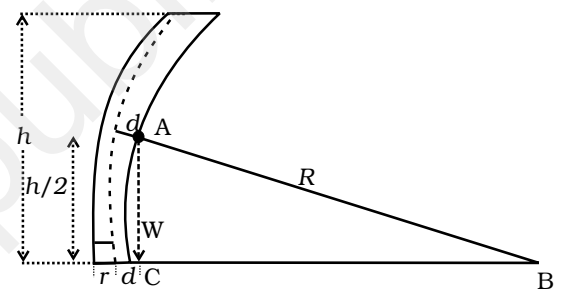

9.29 (a) Till the stone drops through a length L it will be in free fall. After that the elasticity of the string will force it to a SHM. Let the stone come to rest instantaneously at y .

The loss in P.E. of the stone is the P.E. stored in the stretched string.

$$mgy = \frac{1}{2}k(y-L)^2$$

$$\text{Or, } mgy = \frac{1}{2}ky^2 - kyL + \frac{1}{2}kL^2$$

$$\text{Or, } \frac{1}{2}ky^2 - (kL + mg)y + \frac{1}{2}kL^2 = 0$$

$$y = \frac{(kL + mg) \pm \sqrt{(kL + mg)^2 - k^2L^2}}{k}$$

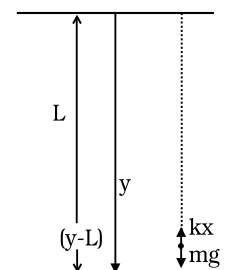

$$= \frac{(kL + mg) \pm \sqrt{2mgkL + m^2g^2}}{k}$$

Retain the positive sign.

$$\therefore y = \frac{(kL + mg) + \sqrt{2mgkL + m^2g^2}}{k}$$

- (b) The maximum velocity is attained when the body passes, through the “equilibrium, position” i.e. when the instantaneous acceleration is zero. That is $mg - kx = 0$ where x is the extension from L :

$$\Rightarrow mg = kx$$

Let the velocity be v . Then

$$\frac{1}{2}mv^2 + \frac{1}{2}kx^2 = mg(L + x)$$

$$\frac{1}{2}mv^2 = mg(L + x) - \frac{1}{2}kx^2$$

Now $mg = kx$

$$x = \frac{mg}{k}$$

$$\begin{aligned} \therefore \frac{1}{2}mv^2 &= mg\left(L + \frac{mg}{k}\right) - \frac{1}{2}k\frac{m^2g^2}{k^2} \\ &= mgL + \frac{m^2g^2}{k} - \frac{1}{2}\frac{m^2g^2}{k} \end{aligned}$$

$$\frac{1}{2}mv^2 = mgL + \frac{1}{2}\frac{m^2g^2}{k}$$

$$\therefore v^2 = 2gL + mg^2/k$$

$$v = (2gL + mg^2/k)^{1/2}$$

- (c) Consider the particle at an instantaneous position y . Then

$$\frac{md^2y}{dt^2} = mg - k(y - L)$$

$$\Rightarrow \frac{d^2y}{dt^2} + \frac{k}{m}(y - L) - g = 0$$

Make a transformation of variables: $z = \frac{k}{m}(y - L) - g$

Then $\frac{d^2z}{dt^2} + \frac{k}{m}z = 0$

$\therefore z = A \cos(\omega t + \phi)$ where $\omega = \sqrt{\frac{k}{m}}$

$\Rightarrow y = \left(L + \frac{m}{k}g\right) + A' \cos(\omega t + \phi)$

Thus the stone performs SHM with angular frequency ω about the point

$y_0 = L + \frac{m}{k}g$

Chapter 10

10.1 (c)

10.2 (d)

10.3 (b)

10.4 (a)

10.5 (c)

10.6 (a), (d)

10.7 (c), (d)

10.8 (a), (b)

10.9 (c), (d)

10.10 (b), (c)

10.11 No.

10.12 No.

10.13 Let the volume of the iceberg be V . The weight of the iceberg is $\rho_i Vg$. If x is the fraction submerged, then the volume of water displaced is xV . The buoyant force is $\rho_w xVg$ where ρ_w is the density of water.

$\rho_i Vg = \rho_w xVg$

$\therefore x = \frac{\rho_i}{\rho_w} = 0.917$

10.14 Let x be the compression on the spring. As the block is in equilibrium

$Mg - (kx + \rho_w Vg) = 0$

where ρ_w is the density of water and V is the volume of the block. The reading in the pan is the force applied by the water on the pan i.e.,

$$m_{\text{vessel}} + m_{\text{water}} + \rho_w Vg.$$

Since the scale has been adjusted to zero without the block, the new reading is $\rho_w Vg$.

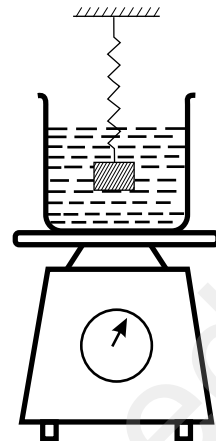

10.15 Let the density of water be ρ_w .

$$\text{Then } \rho aL^3 + \rho L^3g = \rho_w xL^3 (g + a)$$

$$\therefore x = \frac{\rho}{\rho_w}$$

Thus, the fraction of the block submerged is independent of any acceleration, whether gravity or elevator.

10.16 The height to which the sap will rise is

$$h = \frac{2T \cos 0^\circ}{\rho g r} = \frac{2(7.2 \times 10^{-2})}{10^3 \times 9.8 \times 2.5 \times 10^{-5}} \approx 0.6\text{m}$$

This is the maximum height to which the sap can rise due to surface tension. Since many trees have heights much more than this, capillary action alone cannot account for the rise of water in all trees.

10.17 If the tanker accelerates in the positive x direction, then the water will bulge at the back of the tanker. The free surface will be such that the tangential force on any fluid parcel is zero.

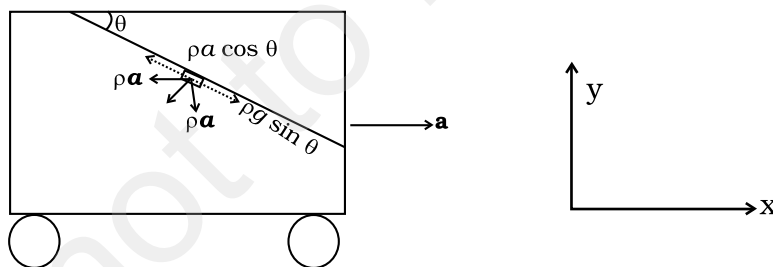

Consider a parcel at the surface, of unit volume. The forces on the fluid are

$$-\rho g \hat{\mathbf{y}} \quad \text{and} \quad -\rho a \hat{\mathbf{x}}$$

The component of the weight along the surface is $\rho g \sin \theta$

The component of the acceleration force along the surface is

$$\rho a \cos \theta$$

$$\therefore \rho g \sin \theta = \rho a \cos \theta$$

Hence, $\tan \theta = a/g$

10.18 Let v_1 and v_2 be the volume of the droplets and v of the resulting drop.

Then $v = v_1 + v_2$

$$\Rightarrow r^3 = r_1^3 + r_2^3 = (0.001 + 0.008) \text{ cm}^3 = 0.009 \text{ cm}^3$$

$$\therefore r = 0.21 \text{ cm}$$

$$\begin{aligned} \therefore \Delta U &= 4\pi T (r^2 - (r_1^2 + r_2^2)) \\ &= 4\pi \times 435.5 \times 10^{-3} (0.21^2 - 0.05) \times 10^{-4} \text{ J} \\ &\approx -32 \times 10^{-7} \text{ J} \end{aligned}$$

10.19 $R^3 = Nr^3$

$$\Rightarrow r = \frac{R}{N^{1/3}}$$

$$\Delta U = 4\pi T (R^2 - Nr^2)$$

Suppose all this energy is released at the cost of lowering the temperature. If s is the specific heat then the change in temperature would be,

$$\Delta \theta = \frac{\Delta U}{ms} = \frac{4\pi T (R^2 - Nr^2)}{\frac{4}{3} \pi R^3 \rho s}, \text{ where } \rho \text{ is the density.}$$

$$\begin{aligned} \therefore \Delta \theta &= \frac{3T}{\rho s} \left(\frac{1}{R} - \frac{r^2}{R^3} N \right) \\ &= \frac{3T}{\rho s} \left(\frac{1}{R} - \frac{r^2 R^3}{R^3 r^3} \right) = \frac{3T}{\rho s} \left(\frac{1}{R} - \frac{1}{r} \right) \end{aligned}$$

10.20 The drop will evaporate if the water pressure is more than the vapour pressure. The membrane pressure (water)

$$p = \frac{2T}{r} = 2.33 \times 10^3 \text{ Pa}$$

$$\therefore r = \frac{2T}{p} = \frac{2(7.28 \times 10^{-2})}{2.33 \times 10^3} = 6.25 \times 10^{-5} \text{ m}$$

- 10.21 (a) Consider a horizontal parcel of air with cross section A and height dh . Let the pressure on the top surface and bottom surface be p and $p+dp$. If the parcel is in equilibrium, then the net upward force must be balanced by the weight.

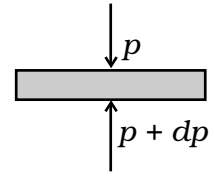

$$\text{i.e. } (p+dp)A - pA = -PgAdh$$

$$\Rightarrow dp = -\rho gdh.$$

- (b) Let the density of air on the earth's surface be ρ_o , then

$$\frac{p}{p_o} = \frac{\rho}{\rho_o}$$

$$\Rightarrow \rho = \frac{\rho_o}{p_o} p$$

$$\therefore dp = -\frac{\rho_o g}{p_o} p dh$$

$$\Rightarrow \frac{dp}{p} = -\frac{\rho_o g}{p_o} dh$$

$$\Rightarrow \int_{p_o}^p \frac{dp}{p} = -\frac{\rho_o g}{p_o} \int_0^h dh$$

$$\Rightarrow \ln \frac{p}{p_o} = -\frac{\rho_o g}{p_o} h$$

$$\Rightarrow p = p_o \exp\left(-\frac{\rho_o g}{p_o} h\right)$$

- (c) $\ln \frac{1}{10} = -\frac{\rho_o g}{p_o} h_o$

$$\therefore h_o = -\frac{p_o}{\rho_o g} \ln \frac{1}{10}$$

$$= \frac{p_o}{\rho_o g} \times 2.303$$

$$= \frac{1.013 \times 10^5}{1.29 \times 9.8} \times 2.303 = 0.16 \times 10^5 \text{ m} = 16 \times 10^3 \text{ m}$$

- (d) The assumption $p \propto \rho$ is valid only for the isothermal case which is only valid for small distances.

10.22 (a) 1 kg of water requires L_v k cal

$\therefore M_A$ kg of water requires $M_A L_v$ k cal

Since there are N_A molecules in M_A kg of water the energy required for 1 molecule to evaporate is

$$\begin{aligned} u &= \frac{M_A L_v}{N_A} \text{ J} \\ &= \frac{18 \times 540 \times 4.2 \times 10^3}{6 \times 10^{26}} \text{ J} \\ &= 90 \times 18 \times 4.2 \times 10^{-23} \text{ J} \\ &\approx 6.8 \times 10^{-20} \text{ J} \end{aligned}$$

(b) Consider the water molecules to be points at a distance d from each other.

N_A molecules occupy $\frac{M_A l}{\rho_w}$

Thus, the volume around one molecule is $\frac{M_A}{N_A \rho_w} l$

The volume around one molecule is $d^3 = (M_A/N_A \rho_w)$

$$\begin{aligned} \therefore d &= \left(\frac{M_A}{N_A \rho_w} \right)^{1/3} = \left(\frac{18}{6 \times 10^{26} \times 10^3} \right)^{1/3} \\ &= (30 \times 10^{-30})^{1/3} \text{ m} \approx 3.1 \times 10^{-10} \text{ m} \end{aligned}$$

(c) 1 kg of vapour occupies $1601 \times 10^{-3} \text{ m}^3$.

\therefore 18 kg of vapour occupies $18 \times 1601 \times 10^{-3} \text{ m}^3$

$\Rightarrow 6 \times 10^{26}$ molecules occupies $18 \times 1601 \times 10^{-3} \text{ m}^3$

\therefore 1 molecule occupies $\frac{18 \times 1601 \times 10^{-3}}{6 \times 10^{26}} \text{ m}^3$

If d' is the inter molecular distance, then

$$d'^3 = (3 \times 1601 \times 10^{-29}) \text{ m}^3$$

$\therefore d' = (30 \times 1601)^{1/3} \times 10^{-10} \text{ m}$

$$= 36.3 \times 10^{-10} \text{ m}$$

$$(d) F(d' - d) = u \Rightarrow F = \frac{u}{d' - d} = \frac{6.8 \times 10^{-20}}{(36.3 - 3.1) \times 10^{-10}} = 0.2048 \times 10^{-10} \text{ N}$$

$$(e) F/d = \frac{0.2048 \times 10^{-10}}{3.1 \times 10^{-10}} = 0.066 \text{ N m}^{-1} = 6.6 \times 10^{-2} \text{ N m}^{-1}$$

10.23 Let the pressure inside the balloon be P_i and the outside pressure be P_o .

$$P_i - P_o = \frac{2\gamma}{r}$$

Considering the air to be an ideal gas

$P_i V = n_i R T_i$ where V is the volume of the air inside the balloon, n_i is the number of moles inside and T_i is the temperature inside, and $P_o V = n_o R T_o$ where V is the volume of the air displaced and n_o is the number of moles displaced and T_o is the temperature outside.

$$n_i = \frac{P_i V}{R T_i} = \frac{M_i}{M_A} \text{ where } M_i \text{ is the mass of air inside and } M_A \text{ is the molar mass of air and } n_o = \frac{P_o V}{R T_o} = \frac{M_o}{M_A} \text{ where } M_o \text{ is the mass of air outside}$$

that has been displaced. If W is the load it can raise, then

$$W + M_i g = M_o g$$

$$\Rightarrow W = M_o g - M_i g$$

Air is 21% O_2 and 79% N_2

$$\therefore \text{Molar mass of air } M_A = 0.21 \times 32 + 0.79 \times 28 = 28.84 \text{ g.}$$

$$\begin{aligned} \Rightarrow W &= \frac{M_A V}{R} \left(\frac{P_o}{T_o} - \frac{P_i}{T_i} \right) g \\ &= \frac{0.02884 \times \frac{4}{3} \pi \times 8^3 \times 9.8}{8.314} \left(\frac{1.013 \times 10^5}{293} - \frac{1.013 \times 10^5}{333} - \frac{2 \times 5}{8 \times 313} \right) \text{ N} \\ &\approx \frac{0.02884 \times \frac{4}{3} \pi \times 8^3}{8.314} \times 1.013 \times 10^5 \left(\frac{1}{293} - \frac{1}{333} \right) \times 9.8 \text{ N} \\ &= 3044.2 \text{ N.} \end{aligned}$$

Chapter 11

11.1 (d)

11.2 (b)

11.3 (b)

11.4 (a)

11.5 (a)

11.6 (a)

11.7 (d)

Original volume $V_0 = \frac{4}{3}\pi R^3$

Coeff of linear expansion = α

\therefore Coeff of volume expansion $\approx 3\alpha$

$$\therefore \frac{1}{V} \frac{dV}{dT} = 3\alpha$$

$$\Rightarrow dV = 3V\alpha dT \approx 4\pi R^3 \alpha \Delta T$$

11.8 (c)

11.9 (b), (d)

11.10 (b)

11.11 (a), (d)

11.12 (b), (c), (d)

11.13 Diathermic

11.14 2 and 3 are wrong, 4th is correct.

11.15 Due to difference in conductivity, metals having high conductivity compared to wood. On touch with a finger, heat from the surrounding flows faster to the finger from metals and so one feels the heat. Similarly, when one touches a cold metal the heat from the finger flows away to the surroundings faster.

11.16 $-40^\circ\text{C} = -40^\circ\text{F}$

11.17 Since Cu has a high conductivity compared to steel, the junction of Cu and steel gets heated quickly but steel does not conduct as quickly, thereby allowing food inside to get heated uniformly.

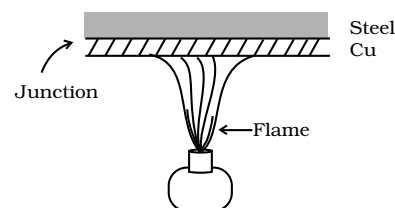

11.18 $I = \frac{1}{12} Ml^2$
 $I' = \frac{1}{12} M(l + \Delta l)^2 = \frac{1}{12} Ml^2 + \frac{1}{12} 2Ml\Delta l + \frac{1}{12} M(\Delta l)^2 \alpha$
 $\approx I + \frac{1}{12} Ml^2 2\alpha\Delta T$
 $= I + 2I\alpha\Delta T$
 $\therefore \Delta I = 2\alpha I\Delta T$

11.19 Refer to the P.T diagram of water and double headed arrow. Increasing pressure at 0°C and 1 atm takes ice into liquid state and decreasing pressure in liquid state at 0°C and 1 atm takes water to ice state.

When crushed ice is squeezed, some of it melts, filling up gap between ice flakes. Upon releasing pressure, this water freezes binding all ice flakes making the ball more stable.

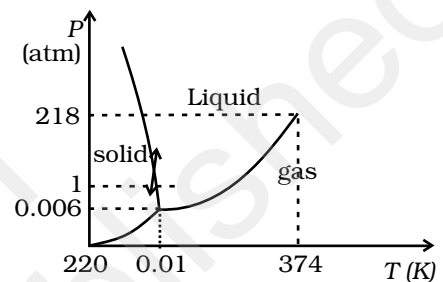

11.20 Resultant mixture reaches 0°C. 12.5 g of ice and rest is water.

11.21 The first option would have kept water warmer because according to Newton's law of cooling, the rate of loss of heat is directly proportional to the difference of temperature of the body and the surrounding and in the first case the temperature difference is less, so rate of loss of heat will be less.

11.22 $l_{iron} - l_{brass} = 10\text{cm}$ at all temperature
 $\therefore l_{iron}^{\circ} (1 + \alpha_{iron} \Delta t) - l_{brass}^{\circ} (1 + \alpha_{brass} \Delta t) = 10\text{cm}$

$$l_{iron}^{\circ} \alpha_{iron} = l_{brass}^{\circ} \alpha_{brass}$$

$$\therefore \frac{l_{iron}^{\circ}}{l_{brass}^{\circ}} = \frac{1.8}{1.2} = \frac{3}{2}$$

$$\therefore \frac{1}{2} l_{brass}^{\circ} = 10\text{cm} \Rightarrow l_{brass}^{\circ} = 20\text{ cm}$$

and $l_{iron}^{\circ} = 30\text{ cm}$

11.23 Iron vessel with a brass rod inside

$$\frac{V_{\text{iron}}}{V_{\text{brass}}} = \frac{6}{3.55}$$

$$V_{\text{iron}} - V_{\text{brass}} = 100\text{cc} = V_0$$

$$V_{\text{brass}}^{\text{rod}} = 144.9\text{cc} \quad V_{\text{iron}}^{\text{inside}} = 244.9\text{cc}$$

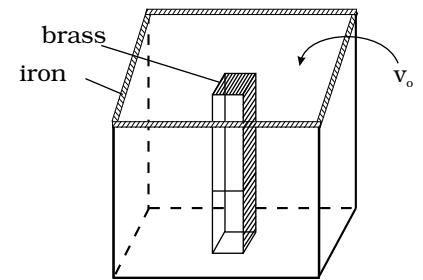

11.24 Stress = $K \times$ strain

$$= K \frac{\Delta V}{V}$$

$$= K(3\alpha)\Delta t$$

$$= 140 \times 10^9 \times 3 \times 1.7 \times 10^{-5} \times 20$$

$$= 1.428 \times 10^8 \text{ N/m}^2$$

This is about 10^3 times atmospheric pressure.

11.25 $x = \sqrt{\left(\frac{L}{2} + \frac{\Delta L}{2}\right)^2 - \left(\frac{L}{2}\right)^2}$

$$\approx \frac{1}{2} \sqrt{2L \Delta L}$$

$$\Delta L = \alpha L \Delta t$$

$$\therefore x \approx \frac{L}{2} \sqrt{2\alpha \Delta t}$$

$$\approx 0.11\text{m} \rightarrow 11\text{cm}$$

11.26 Method I

Temperature θ at a distance x from one end (that at θ_1) is given by

$$\theta = \theta_1 + \frac{x}{L_0}(\theta_2 - \theta_1) : \text{linear temperature gradient.}$$

New length of small element of length dx_0

$$dx = dx_0 (1 + \alpha\theta)$$

$$= dx_0 + dx_0 \alpha \left[\theta_1 + \frac{x}{L_0}(\theta_2 - \theta_1) \right]$$

Now $\int dx_0 = L_0$ and $\int dx = L$: new length

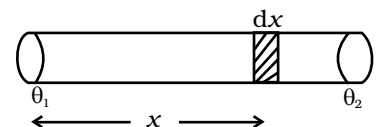

Integrating

$$\begin{aligned} \therefore L &= L_o + L_o \alpha \theta_1 + \frac{(\theta_2 - \theta_1)}{L_o} \alpha \int x \, dx_o \\ &= L_o \left(1 + \frac{1}{2} \alpha (\theta_2 + \theta_1) \right) \text{ as } \int_0^{L_o} x dx = \frac{1}{2} L_o^2 \end{aligned}$$

Method II

If temperature of the rod varies linearly, we can assume average temperature to be $\frac{1}{2}(\theta_1 + \theta_2)$ and hence new length

$$L = L_o \left(1 + \frac{1}{2} \alpha (\theta_2 + \theta_1) \right)$$

11.27 (i) 1.8×10^{17} J/S (ii) 7×10^9 kg

(iii) 47.7 N/m².

Chapter 12

12.1 (c) adiabatic

A is isobaric process, D is isochoric. Of B and C, B has the smaller slope (magnitude) hence is isothermal. Remaining process is adiabatic.

12.2 (a)

12.3 (c)

12.4 (b)

12.5 (a)

12.6 (b)

12.7 (a), (b) and (d).

12.8 (a), (d)

12.9 (b), (c)

12.10 (a), (c)

12.11 (a), (c)

12.12 If the system does work against the surroundings so that it compensates for the heat supplied, the temperature can remain constant.

12.13 $U_p - U_Q = \text{W.D. in path 1 on the system} + 1000 \text{ J}$
 $= \text{W.D. in path 2 on the system} + Q$

$$Q = (-100 + 1000) \text{ J} = 900 \text{ J}$$

12.14 Here heat removed is less than the heat supplied and hence the room, including the refrigerator (which is not insulated from the room) becomes hotter.

12.15 Yes. When the gas undergoes adiabatic compression, its temperature increases.

$$dQ = dU + dW$$

As $dQ = 0$ (adiabatic process)

$$\text{so } dU = -dW$$

In compression, work is done on the system So, $dW = -ve$

$$\Rightarrow dU = +ve$$

So internal energy of the gas increases, i.e. its temperature increases.

12.16 During driving, temperature of the gas increases while its volume remains constant.

So according to Charle's law, at constant V , $P \propto T$.

Therefore, pressure of gas increases.

12.17 $\frac{Q}{Q_1} = \frac{T_2}{T_1} = \frac{3}{5}$, $Q_1 - Q_2 = 10^3 \text{ J}$

$$Q_1 \left(1 - \frac{3}{5}\right) = 10^3 \text{ J} \Rightarrow Q_1 = \frac{5}{2} \times 10^3 \text{ J} = 2500 \text{ J}, Q_2 = 1500 \text{ J}$$

12.18 $5 \times 7000 \times 10^3 \times 4.2 \text{ J} = 60 \times 15 \times 10 \times N$

$$N = \frac{21 \times 7 \times 10^6}{900} = \frac{147}{9} \times 10^3 = 16.3 \times 10^3 \text{ times.}$$

12.19 $P(V + \Delta v)^\gamma = (P + \Delta p)V^\gamma$

$$P \left[1 + \gamma \frac{\Delta v}{V} \right] = P \left(1 + \frac{\Delta p}{P} \right)$$

$$\gamma \frac{\Delta v}{V} = \frac{\Delta p}{P}; \frac{dv}{dp} = \frac{V}{\gamma p}$$

$$\text{W.D.} = \int_{P_1}^{P_2} p \, dv = \int_{P_1}^{P_2} p \frac{V}{\gamma p} dp = \frac{(P_2 - P_1)}{\gamma} V$$

12.20 $\eta = 1 - \frac{270}{300} = \frac{1}{10}$

Efficiency of refrigerator = $0.5\eta = \frac{1}{20}$

If Q is the heat/s transferred at higher temperature then $\frac{W}{Q} = \frac{1}{20}$
 or $Q = 20W = 20 \text{ kJ}$,

and heat removed from lower temperature = 19 kJ .

12.21 $\frac{Q_2}{W} = 5, Q_2 = 5W, Q_1 = 6W$

$$\frac{T_2}{T_1} = \frac{5}{6} = \frac{T}{300}, T_2 = 250 \text{ K} = -23^\circ \text{C}$$

12.22 The P - V diagram for each case is shown in the figure. In case (i) $P_1 V_1 = P_f V_f$; therefore process is isothermal. Work done = area under the PV curve so work done is more when the gas expands at constant pressure.

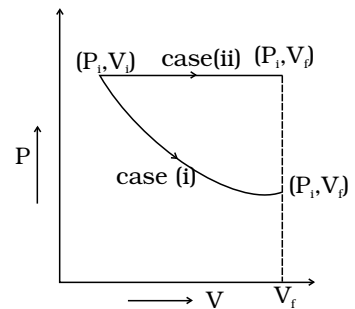

12.23 (a) Work done by the gas (Let $PV^{1/2} = A$)

$$\begin{aligned} \Delta W &= \int_{V_1}^{V_2} p \, dv = A \int_{V_1}^{V_2} \frac{dV}{\sqrt{V}} = A \left[\frac{\sqrt{V}}{1/2} \right]_{V_1}^{V_2} = 2A(\sqrt{V_2} - \sqrt{V_1}) \\ &= 2P_1 V_1^{1/2} [V_2^{1/2} - V_1^{1/2}] \end{aligned}$$

(b) Since $T = pV / nR = \frac{A}{nR} \cdot \sqrt{V}$

Thus, $\frac{T_2}{T_1} = \sqrt{\frac{V_2}{V_1}} = \sqrt{2}$

(c) Then, the change in internal energy

$$\Delta U = U_2 - W_1 = \frac{3}{2} R(T_2 - T_1) = \frac{3}{2} RT_1 (\sqrt{2} - 1)$$

$$\Delta W = 2A\sqrt{V_1}(\sqrt{2} - 1) = 2RT_1(\sqrt{2} - 1)$$

$$\Delta Q = (7/2)RT_1(\sqrt{2} - 1)$$

12.24 (a) A to B

(b) C to D

(c) $W_{AB} = \int_A^B p dV = 0; W_{CD} = 0.$

Similarly, $W_{BC} = \left[\int_B^C p dV = k \int_B^C \frac{dV}{V^\gamma} = k \frac{V^{-\gamma+1}}{-\gamma+1} \right]_{V_B}^{V_C}$

$$= \frac{1}{1-\gamma} (P_C V_C - P_B V_B)$$

Similarly, $W_{DA} = \frac{1}{1-\gamma} (P_A V_A - P_D V_D)$

Now $P_C = P_B \left(\frac{V_B}{V_C} \right)^\gamma = 2^{-\gamma} P_B$

Similarly, $P_D = P_A 2^{-\gamma}$

Total work done = $W_{BC} + W_{DA}$

$$= \frac{1}{1-\gamma} [P_B V_B (2^{-\gamma+1} - 1) - P_A V_A (2^{-\gamma+1} - 1)]$$

$$= \frac{1}{1-\gamma} (2^{1-\gamma} - 1)(P_B - P_A)V_A$$

$$= \frac{3}{2} \left(1 - \left(\frac{1}{2} \right)^{2/3} \right) (P_B - P_A)V_A$$

(d) Heat supplied during process A, B

$$dQ_{AB} = dU_{AB}$$

$$Q_{AB} = \frac{3}{2} nR(T_B - T_A) = \frac{3}{2} (P_B - P_A)V_A$$

$$\text{Efficiency} = \frac{\text{Net Work done}}{\text{Heat Supplied}} = \left[1 - \left(\frac{1}{2} \right)^{2/3} \right]$$

12.25 $Q_{AB} = U_{AB} = \frac{3}{2} R(T_B - T_A) = \frac{3}{2} V_A(P_B - P_A)$

$$Q_{BC} = U_{BC} + W_{BC}$$

$$= (3/2) P_B(V_C - V_B) + P_B(V_C - V_B)$$

$$= (5/2) P_B(V_C - V_A)$$

$$Q_{CA} = 0$$

$$Q_{DA} = (5/2) P_A (V_A - V_D)$$

12.26 Slope of $P = f(V)$, curve at (V_o, P_o)

$$= f'(V_o)$$

Slope of adiabat at (V_o, P_o)

$$= k(-\gamma) V_o^{-1-\gamma} = -\gamma P_o/V_o$$

Now heat absorbed in the process $P = f(V)$

$$dQ = dV + dW$$

$$= nC_v dT + P dV$$

Since $T = (1/nR) PV = (1/nR) V f(V)$

$$dT = (1/nR) [f(V) + V f'(V)] dV$$

Thus

$$\frac{dQ}{dV} \Big|_{V=V_o} = \frac{CV}{R} [f(V_o) + V_o f'(V_o)] + f(V_o)$$

$$= \left[\frac{1}{\gamma-1} + 1 \right] f(V_o) + \frac{V_o f'(V_o)}{\gamma-1}$$

$$= \frac{\gamma}{\gamma-1} P_o + \frac{V_o}{\gamma-1} f'(V_o)$$

Heat is absorbed when $dQ/dV > 0$ when gas expands, that is when

$$\gamma P_o + V_o f'(V_o) > 0$$

$$f'(V_o) > -\gamma P_o/V_o$$

12.27 (a) $P_i = P_a$

(b) $P_f = P_a + \frac{k}{A}(V - V_o) = P_a + k(V - V_o)$

(c) All the supplied heat is converted to mechanical energy. No change in internal energy (Perfect gas)

$$\Delta Q = P_a(V - V_o) + \frac{1}{2}k(V - V_o)^2 + C_V(T - T_o)$$

where $T_o = P_a V_o/R$,

$$T = [P_a + (R/A)(V - V_o)]V/R$$

Chapter 13

13.1 (b)

Comment for discussion: This brings in concepts of relative motion and that when collision takes place, it is the relative velocity which changes.

13.2 (d)

Comment for discussion: In the ideal case that we normally consider, each collision transfers twice the magnitude of its normal momentum. On the face EFGH, it transfers only half of that.

13.3 (b)

13.4 (c) This is a constant pressure ($p = Mg/A$) arrangement.

13.5 (a)

13.6 (d)

Comment for discussion: The usual statement for the perfect gas law somehow emphasizes molecules. If a gas exists in atomic form (perfectly possible) or a combination of atomic and molecular form, the law is not clearly stated.

13.7 (b)

Comment: In a mixture, the average kinetic energy are equating. Hence, distribution in velocity are quite different.

13.8 (d)

Comment for discussion: In this chapter, one has discussed constant pressure and constant volume situations but in real life there are many situations where both change. If the surfaces were rigid, p would rise to 1.1 p . However, as the pressure rises, V also rises such that pV finally is 1.1 RT with $p_{\text{final}} > p$ and $V_{\text{final}} > V$. Hence (d).

13.9 (b),(d)

13.10 (c)

13.11 (a), (d)

Comment : The equation $\langle \text{K.E. of translation} \rangle = \left(\frac{3}{2}\right)RT$, $\langle \text{Rotational energy} \rangle = RT$ is taught. The fact that the distribution of the two is independent of each other is not emphasized. They are independently Maxwellian.

13.12 (a), (c)

13.13 (a)

Comment : Conceptually, it is not often clear to the students that elastic collisions with a moving object leads to change in its energy.

13.14 \therefore Molar mass of gold is 197 g mole^{-1} , the number of atoms = 6.0×10^{23}

$$\therefore \text{No. of atoms in } 39.4\text{g} = \frac{6.0 \times 10^{23} \times 39.4}{197} = 1.2 \times 10^{23}$$

13.15 Keeping P constant, we have

$$V_2 = \frac{V_1 T_2}{T_1} = \frac{100 \times 600}{300} = 200\text{cc}$$

13.16 $\frac{P_1 V_1}{T_1} = \frac{P_2 V_2}{T_2}$

$$\frac{V_1}{V_2} = \frac{P_2 T_1}{P_1 T_2} = \frac{2 \times 300}{400} = \frac{3}{2}$$

$$P_1 = \frac{1}{3} \frac{M}{V_1} c_1^{-2}; \quad P_2 = \frac{1}{3} \frac{M}{V_2} c_2^{-2}$$

$$\begin{aligned} \therefore c_2^2 &= c_1^2 \times \frac{V_2}{V_1} \times \frac{P_2}{P_1} \\ &= (100)^2 \times \frac{2}{3} \times 2 \end{aligned}$$

$$c_2 = \frac{200}{\sqrt{3}} \text{ m s}^{-1}$$

13.17 $v_{rms} = \sqrt{\frac{v_1^2 + v_2^2}{2}}$

$$\begin{aligned} &= \sqrt{\frac{(9 \times 10^6)^2 + (1 \times 10^6)^2}{2}} \\ &= \sqrt{\frac{(81 + 1) \times 10^{12}}{2}} = \sqrt{41} \times 10^6 \text{ m s}^{-1}. \end{aligned}$$

13.18 O_2 has 5 degrees of freedom. Therefore, energy per mole = $\frac{5}{2}RT$

\therefore For 2 moles of O_2 , energy = $5RT$

Neon has 3 degrees of freedom \therefore Energy per mole = $\frac{3}{2}RT$

\therefore For 4 mole of neon, energy = $4 \times \frac{3}{2}RT = 6RT$

\therefore Total energy = $11RT$.

$$13.19 \quad l \propto \frac{1}{d^2}$$

$$d_1 = 1 \text{ \AA} \quad \alpha_2 = 2 \text{ \AA}$$

$$l_1 : l_2 = 4 : 1$$

$$13.20 \quad V_1 = 2.0 \text{ litre} \quad V_2 = 3.0 \text{ litre}$$

$$\mu_1 = 4.0 \text{ moles} \quad \mu_2 = 5.0 \text{ moles}$$

$$P_1 = 1.00 \text{ atm} \quad P_2 = 2.00 \text{ atm}$$

$$P_1 V_1 = \mu_1 R T_1 \quad P_2 V_2 = \mu_2 R T_2$$

$$\mu = \mu_1 + \mu_2 \quad V = V_1 + V_2$$

$$\text{For 1 mole } PV = \frac{2}{3} E$$

$$\text{For } \mu_1 \text{ moles } P_1 V_1 = \frac{2}{3} \mu_1 E_1$$

$$\text{For } \mu_2 \text{ moles } P_2 V_2 = \frac{2}{3} \mu_2 E_2$$

$$\text{Total energy is } (\mu_1 E_1 + \mu_2 E_2) = \frac{3}{2} (P_1 V_1 + P_2 V_2)$$

$$PV = \frac{2}{3} E_{\text{total}} = \frac{2}{3} \mu E_{\text{per mole}}$$

$$P(V_1 + V_2) = \frac{2}{3} \times \frac{3}{2} (P_1 V_1 + P_2 V_2)$$

$$P = \frac{P_1 V_1 + P_2 V_2}{V_1 + V_2} \quad *$$

$$= \left(\frac{1.00 \times 2.0 + 2.00 \times 3.0}{2.0 + 3.0} \right) \text{ atm}$$

$$= \frac{8.0}{5.0} = 1.60 \text{ atm.}$$

Comment: This form of ideal gas law represented by Equation marked* becomes very useful for adiabatic changes.

13.21 The average K.E will be the same as conditions of temperature and pressure are the same

$$v_{\text{rms}} \propto \frac{1}{\sqrt{m}}$$

$$\therefore m_A > m_B > m_C$$

$$v_C > v_B > v_A$$

13.22 We have $0.25 \times 6 \times 10^{23}$ molecules, each of volume 10^{-30}m^3 .

Molecular volume = $2.5 \times 10^{-7} \text{m}^3$

Supposing Ideal gas law is valid.

$$\text{Final volume} = \frac{V_{in}}{100} = \frac{(3)^3 \times 10^{-6}}{100} \approx 2.7 \times 10^{-7} \text{m}^3$$

which is about the molecular volume. Hence, intermolecular forces cannot be neglected. Therefore the ideal gas situation does not hold.

13.23 When air is pumped, more molecules are pumped in. Boyle's law is stated for situation where number of molecules remain constant.

13.24 $\mu = 5.0$

$T = 280 \text{K}$

No of atoms = $\mu N_A = 5.0 \times 6.02 \times 10^{23}$

$$= 30 \times 10^{23}$$

Average kinetic energy per molecule = $\frac{3}{2} kT$

$$\begin{aligned} \therefore \text{Total internal energy} &= \frac{3}{2} kT \times N \\ &= \frac{3}{2} \times 30 \times 10^{23} \times 1.38 \times 10^{-23} \times 280 \\ &= 1.74 \times 10^4 \text{ J} \end{aligned}$$

13.25 Volume occupied by 1 gram mole of gas at NTP = 22400cc

\therefore Number of molecules in 1cc of hydrogen

$$= \frac{6.023 \times 10^{23}}{22400} = 2.688 \times 10^{19}$$

As each diatomic molecule has 5 degrees of freedom, hydrogen being diatomic also has 5 degrees of freedom

$$\begin{aligned} \therefore \text{Total no of degrees of freedom} &= 5 \times 2.688 \times 10^{19} \\ &= 1.344 \times 10^{20} \end{aligned}$$

13.26 Loss in K.E of the gas = $\Delta E = \frac{1}{2} (mn)v_o^2$

where $n = \text{no: of moles}$.

If its temperature changes by ΔT , then

$$n \frac{3}{2} R \Delta T = \frac{1}{2} mn v_o^2 \quad \therefore \Delta T = \frac{mv_o^2}{3R}$$

13.27 The moon has small gravitational force and hence the escape velocity is small. As the moon is in the proximity of the Earth as seen from the Sun, the moon has the same amount of heat per unit area as that of the Earth. The air molecules have large range of speeds. Even though the rms speed of the air molecules is smaller than the escape velocity on the moon, a significant number of molecules have speed greater than escape velocity and they escape. Now rest of the molecules arrange the speed distribution for the equilibrium temperature. Again a significant number of molecules escape as their speeds exceed escape speed. Hence, over a long time the moon has lost most of its atmosphere.

$$\text{At } 300 \text{ K} \quad V_{rms} = \sqrt{\frac{3kT}{m}} = \sqrt{\frac{3 \times 1.38 \times 10^{-23} \times 300}{7.3 \times 10^{-26}}} = 1.7 \text{ km/s}$$

$$V_{esc} \text{ for moon} = 4.6 \text{ km/s}$$

(b) As the molecules move higher their potential energy increases and hence kinetic energy decreases and hence temperature reduces.

At greater height more volume is available and gas expands and hence some cooling takes place.

13.28 (This problem is designed to give an idea about cooling by evaporation)

(i)

$$\begin{aligned} V_{rms}^2 &= \frac{\sum_i n_i v_i^2}{\sum_i n_i} \\ &= \frac{10 \times (200)^2 + 20 \times (400)^2 + 40 \times (600)^2 + 20 \times (800)^2 + 10 \times (1000)^2}{100} \\ &= \frac{10 \times 100^2 \times (1 \times 4 + 2 \times 16 + 4 \times 36 + 2 \times 64 + 1 \times 100)}{100} \\ &= 1000 \times (4 + 32 + 144 + 128 + 100) = 408 \times 1000 \text{ m}^2/\text{s}^2 \end{aligned}$$

$$\therefore v_{rms} = 639 \text{ m/s}$$

$$\frac{1}{2} m v_{rms}^2 = \frac{3}{2} kT$$

$$\therefore T = \frac{1}{3} \frac{m v_{rms}^2}{k} = \frac{1}{3} \times \frac{3.0 \times 10^{-26} \times 4.08 \times 10^5}{1.38 \times 10^{-23}}$$

$$= 2.96 \times 10^2 \text{ K} = 296 \text{ K}$$

$$\begin{aligned}
 \text{(ii) } V_{rms}^2 &= \frac{10 \times (200)^2 + 20 \times (400)^2 + 40 \times (600)^2 + 20 \times (800)^2}{90} \\
 &= \frac{10 \times 100^2 \times (1 \times 4 + 2 \times 16 + 4 \times 36 + 2 \times 64)}{90} \\
 &= 10000 \times \frac{308}{9} = 342 \times 1000 \text{ m}^2/\text{s}^2
 \end{aligned}$$

$$v_{rms} = 584 \text{ m/s}$$

$$T = \frac{1}{3} \frac{mV_{rms}^2}{k} = 248 \text{ K}$$

13.29 Time $t = \frac{\lambda}{v}$

$$\lambda = \frac{1}{\sqrt{2}\pi d^2 n}, \text{ } d = \text{diameter and } n = \text{number density}$$

$$n = \frac{N}{V} = \frac{10}{20 \times 20 \times 1.5} = 0.0167 \text{ km}^{-3}$$

$$\begin{aligned}
 t &= \frac{1}{\sqrt{2}\pi d^2 (N/V) \times v} \\
 &= \frac{1}{1.414 \times 3.14 \times (20)^2 \times 0.0167 \times 10^{-3} \times 150}
 \end{aligned}$$

$$= 225 \text{ h}$$

13.30 V_{1x} = speed of molecule inside the box along x direction

n_1 = number of molecules per unit volume

In time Δt , particles moving along the wall will collide if they are within $(V_{1x}\Delta t)$ distance. Let a = area of the wall. No. of particles colliding in time $\Delta t = \frac{1}{2}n_1(V_{1x}\Delta t)a$ (factor of $1/2$ due to motion towards wall).

In general, gas is in equilibrium as the wall is very large as compared to hole.

$$\therefore V_{1x}^2 + V_{1y}^2 + V_{1z}^2 = V_{rms}^2$$

$$\therefore V_{1x}^2 = \frac{V_{rms}^2}{3}$$

$$\frac{1}{2}mV_{rms}^2 = \frac{3}{2}kT \Rightarrow V_{rms}^2 = \frac{3kT}{m}$$

$$\therefore V_{1x}^2 = \frac{kT}{m}$$

$$\therefore \text{No. of particles colliding in time } \Delta t = \frac{1}{2}n_1\sqrt{\frac{kT}{m}}\Delta t a. \text{ If particles}$$

collide along hole, they move out. Similarly outer particles colliding along hole will move in.

∴ Net particle flow in time $\Delta t = \frac{1}{2}(n_1 - n_2)\sqrt{\frac{kT}{m}}\Delta t a$ as temperature is same in and out.

$$pV = \mu RT \Rightarrow \mu = \frac{PV}{RT}$$

$$n = \frac{\mu N_A}{V} = \frac{PN_A}{RT}$$

After some time τ pressure changes to p_1' inside

$$\therefore n_1' = \frac{P_1' N_A}{RT}$$

$$n_1 V - n_1' V = \text{no. of particle gone out} = \frac{1}{2}(n_1 - n_2)\sqrt{\frac{kT}{m}}\tau a$$

$$\therefore \frac{P_1 N_A}{RT} V - \frac{P_1' N_A}{RT} V = \frac{1}{2}(P_1 - P_2) \frac{N_A}{RT} \sqrt{\frac{kT}{m}}\tau a$$

$$\therefore \tau = 2 \left(\frac{P_1 - P_1'}{P_1 - P_2} \right) \frac{V}{a} \sqrt{\frac{m}{kT}}$$

$$= 2 \left(\frac{1.5 - 1.4}{1.5 - 1.0} \right) \frac{5 \times 1.00}{0.01 \times 10^{-6}} \sqrt{\frac{46.7 \times 10^{-27}}{1.38 \times 10^{-23} \times 300}}$$

$$= 1.38 \times 10^5 \text{ s}$$

13.31 n = no. of molecules per unit volume

v_{rms} = rms speed of gas molecules

When block is moving with speed v_o , relative speed of molecules w.r.t.

front face = $v + v_o$

Coming head on, momentum transferred to block per collision

$$= 2m(v + v_o), \text{ where } m = \text{mass of molecule.}$$

No. of collision in time $\Delta t = \frac{1}{2}(v + v_o)n\Delta t A$, where A = area of cross section of block and factor of $1/2$ appears due to particles moving towards block.

∴ Momentum transferred in time $\Delta t = m(v + v_o)^2 n A \Delta t$ from front surface

Similarly momentum transferred in time $\Delta t = m(v - v_o)^2 n A \Delta t$ from back surface

$$\therefore \text{Net force (drag force)} = mnA[(v + v_o) - (v - v_o)^2] \text{ from front}$$

$$= mnA(4vv_o) = (4mnAv)v_o$$

$$= (4\rho Av)v_o$$

We also have $\frac{1}{2}mv^2 = \frac{1}{2}kT$ (v - is the velocity along x -axis)

Therefore, $v = \sqrt{\frac{kT}{m}}$.

Thus drag $= 4\rho A\sqrt{\frac{kT}{m}}v_0$.

Chapter 14

- 14.1 (b)
 14.2 (b)
 14.3 (d)
 14.4 (c)
 14.5 (c)
 14.6 (d)
 14.7 (b)
 14.8 (a)
 14.9 (c)
 14.10 (a)
 14.11 (b)
 14.12 (a), (c)
 14.13 (a), (c)
 14.14 (d), (b)
 14.15 (a), (b), (d)
 14.16 (a), (b), (c)
 14.17 (a), (b) (d)
 14.18 (a), (c), (d)
 14.19 (i) (A),(C),(E),(G) (ii) (B), (D), (F), (H)
 14.20 $2kx$ towards left.
 14.21 (a) Acceleration is directly proportional to displacement.
 (b) Acceleration is directed opposite to displacement.
 14.22 When the bob of the pendulum is displaced from the mean position so that $\sin\theta \cong \theta$

14.23 $+\omega$

14.24 Four

14.25 -ve

14.27

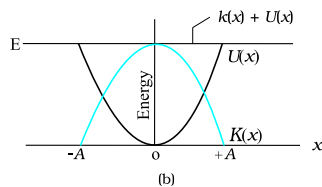

14.28 $l_m = \frac{1}{6} l_E = \frac{1}{6} m$

14.29 If mass m moves down by h , then the spring extends by $2h$ (because each side expands by h). The tension along the string and spring is the same.

In equilibrium

$$mg = 2(k \cdot 2h)$$

where k is the spring constant.

On pulling the mass down by x ,

$$F = mg - 2k(2h + 2x)$$

$$= -4kx$$

So, $T = 2\pi\sqrt{\frac{m}{4k}}$

14.30 $y = \sqrt{2} \sin(\omega t - \pi/4); T = 2\pi/\omega$

14.31 $\frac{A}{\sqrt{2}}$

14.32 $U = U_0(1 - \cos \alpha x)$

$$F = \frac{-dU}{dx} = \frac{-d}{dx}(U_0 - U_0 \cos \alpha x)$$

$$= -U_0 \alpha \sin \alpha x$$

$$\approx -U_0 \alpha \alpha x \quad (\text{for small } \alpha x, \sin \alpha x \sim \alpha x)$$

$$= -U_0 \alpha^2 x$$

We know that $F = -kx$

So, $k = U_0 \alpha^2$

$$T = 2\pi\sqrt{\frac{m}{U_0 \alpha^2}}$$

14.33 $x = 5 \sin 5t$.

14.34 $\theta_1 = \theta_o \sin(\omega t + \delta_1)$

$\theta_2 = \theta_o \sin(\omega t + \delta_2)$

For the first, $\theta = 2^\circ, \therefore \sin(\omega t + \delta_1) = 1$

For the 2nd, $\theta = -1^\circ, \therefore \sin(\omega t + \delta_2) = -1/2$

$\therefore \omega t + \delta_1 = 90^\circ, \omega t + \delta_2 = -30^\circ$

$\therefore \delta_1 - \delta_2 = 120^\circ$

14.35 (a) Yes.

(b) Maximum weight = $Mg + MA\omega^2$

$= 50 \times 9.8 + 50 \times \frac{5}{100} \times (2\pi \times 2)^2$

$= 490 + 400 = 890\text{N}.$

Minimum weight = $Mg - MA\omega^2$

$= 50 \times 9.8 - 50 \times \frac{5}{100} \times (2\pi \times 2)^2$

$= 490 - 400$

$= 90\text{ N}.$

Maximum weight is at the topmost position,

Minimum weight is at the lowermost position.

14.36 (a) 2cm (b) 2.8 s^{-1}

14.37 Let the log be pressed and let the vertical displacement at the equilibrium position be x_o .

At equilibrium

$mg = \text{Buoyant force}$

$= Ax_o\rho g$

When it is displaced by a further displacement x , the buoyant force

is $A(x_o + x)\rho g$.

Net restoring force

$= \text{Buoyant force} - \text{weight}$

$= A(x_o + x)\rho g - mg$

$= (A\rho g)x$. i.e. proportional to x .

$\therefore T = 2\pi \sqrt{\frac{m}{A\rho g}}$

14.38 Consider the liquid in the length dx . It's mass is $A\rho dx$ at a height x .

$$PE = A\rho dx gx$$

The PE of the left column

$$= \int_0^{h_1} A\rho g x dx$$

$$= A\rho g \frac{x^2}{2} \Big|_0^{h_1} = A\rho g \frac{h_1^2}{2} = \frac{A\rho g l^2 \sin^2 45^\circ}{2}$$

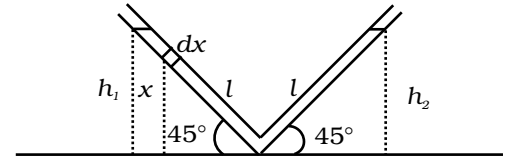

Similarly, P.E. of the right column $= A\rho g \frac{h_2^2}{2} = \frac{A\rho g l^2 \sin^2 45^\circ}{2}$

$h_1 = h_2 = l \sin 45^\circ$ where l is the length of the liquid in one arm of the tube.

$$\text{Total P.E.} = A\rho g h^2 = A\rho g l^2 \sin^2 45^\circ = \frac{A\rho g l^2}{2}$$

If the change in liquid level along the tube in left side is y , then length of the liquid in left side is $l-y$ and in the right side is $l+y$.

$$\text{Total P.E.} = A\rho g(l-y)^2 \sin^2 45^\circ + A\rho g(l+y)^2 \sin^2 45^\circ$$

$$\text{Change in PE} = (PE)_f - (PE)_i$$

$$= \frac{A\rho g}{2} [(l-y)^2 + (l+y)^2 - l^2]$$

$$= \frac{A\rho g}{2} [l^2 + y^2 - 2ly + l^2 + y^2 + 2ly - l^2]$$

$$= A\rho g [y^2 + l^2]$$

$$\text{Change in K.E.} = \frac{1}{2} A\rho 2ly^2$$

$$\text{Change in total energy} = 0$$

$$\Delta(P.E) + \Delta(K.E) = 0$$

$$A\rho g [l^2 + y^2] + A\rho ly^2 = 0$$

Differentiating both sides w.r.t. time,

$$A\rho g \left[0 + 2y \frac{dy}{dt} \right] + 2A\rho l \ddot{y} = 0$$

$$2A\rho g y + 2A\rho l \ddot{y} = 0$$

$$l\ddot{y} + gy = 0$$

$$\ddot{y} + \frac{g}{l}y = 0$$

$$\omega^2 = \frac{g}{l}$$

$$\omega = \sqrt{\frac{g}{l}}$$

$$T = 2\pi\sqrt{\frac{l}{g}}$$

- 14.39** Acceleration due to gravity at $P = \frac{g \cdot x}{R}$, where g is the acceleration at the surface.

$$\text{Force} = \frac{mgx}{R} = -k \cdot x, \quad k = \frac{mg}{R}$$

$$\text{Motion will be SHM with time period } T = \sqrt{\frac{m}{K}} = 2\pi\sqrt{\frac{R}{g}}$$

- 14.40** Assume that $t = 0$ when $\theta = \theta_0$. Then,

$$\theta = \theta_0 \cos \omega t$$

Given a seconds pendulum $\omega = 2\pi$

At time t_1 , let $\theta = \theta_0/2$

$$\therefore \cos 2\pi t_1 = 1/2 \Rightarrow t_1 = \frac{1}{6}$$

$$\dot{\theta} = -\theta_0 2\pi \sin 2\pi t \quad \left[\dot{\theta} = \frac{d\theta}{dt} \right]$$

At $t_1 = 1/6$

$$\dot{\theta} = -\theta_0 2\pi \sin \frac{2\pi}{6} = -\sqrt{3}\pi\theta_0$$

Thus the linear velocity is

$$u = -\sqrt{3}\pi\theta_0 l \quad \text{perpendicular to the string.}$$

The vertical component is

$$u_y = -\sqrt{3}\pi\theta_0 l \sin \theta_0$$

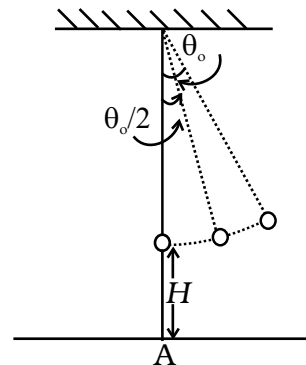

and the horizontal component is

$$u_x = -\sqrt{3}\pi\theta_0 l \cos \theta_0$$

At the time it snaps, the vertical height is

$$H' = H + l(1 - \cos(\theta_0 / 2))$$

Let the time required for fall be t , then

$$H' = u_y t + (1/2)gt^2 \quad (\text{notice } g \text{ is also in the negative direction})$$

$$\text{Or, } \frac{1}{2}gt^2 + \sqrt{3}\pi\theta_0 l \sin \theta_0 t - H' = 0$$

$$\begin{aligned} \therefore t &= \frac{-\sqrt{3}\pi\theta_0 l \sin \theta_0 \pm \sqrt{3\pi^2\theta_0^2 l^2 \sin^2 \theta_0 + 2gH'}}{g} \\ &= \frac{-\sqrt{3}\pi l \theta_0^2 \pm \sqrt{3\pi^2 \theta_0^4 l^2 + 2gH'}}{g} \end{aligned}$$

Neglecting terms of order θ_0^2 and heigher,

$$t \approx \sqrt{\frac{2H'}{g}}$$

$$\text{Now } H' \approx H + l(1 - 1) = H \therefore t \approx \sqrt{\frac{2H}{g}}$$

The distance travelled in the x direction is $u_x t$ to the left of where it snapped.

$$X = \sqrt{3}\pi\theta_0 l \cos \theta_0 \sqrt{\frac{2H}{g}}$$

To order of θ_0 ,

$$X = \sqrt{3}\pi\theta_0 l \sqrt{\frac{2H}{g}} = \sqrt{\frac{6H}{g}}\theta_0 l.$$

At the time of snapping, the bob was

$$l \sin \theta_0 \approx l\theta_0 \text{ distance from A.}$$

Thus, the distance from A is

$$l\theta_0 - \sqrt{\frac{6H}{g}}l\theta_0 = l\theta_0 (1 - \sqrt{6H/g}).$$

Chapter 15

- 15.1 (b)
 15.2 (c)
 15.3 (c)
 15.4 (c)
 15.5 (b)
 15.6 (c)
 15.7 (d)
 15.8 (b)
 15.9 (b)
 15.10 (c)
 15.11 (a), (b), (c)
 15.12 (b), (c)
 15.13 (c), (d)
 15.14 (b), (c), (d)
 15.15 (a), (b), (d)
 15.16 (a), (b)
 15.17 (a), (b), (d), (e)
 15.18 Wire of twice the length vibrates in its second harmonic. Thus if the tuning fork resonates at L , it will resonate at $2L$.
 15.19 $L/2$ as λ is constant.
 15.20 517 Hz.
 15.21 5cm
 15.22 $1/3$. Since frequency $\propto \sqrt{\frac{1}{m}}$ $m = \pi r^2 \rho$
 15.23 2184°C , since $C \propto \sqrt{T}$
 15.24 $\frac{1}{n_1 - n_2}$
 15.25 343 m s^{-1} . $\left[n = \frac{1}{2l} \sqrt{\frac{T}{m}} \right]$
 15.26 3rd harmonic $\left[\text{since } n_o = \frac{v}{4l} = 412.5 \text{ with } v = 330 \text{ m/s} \right]$
 15.27 412.5 Hz $\left[n' = n \left(\frac{c}{c - v} \right) \right]$

15.28 Stationary waves; 20cm

15.29 (a) 9.8×10^{-4} s. (b) Nodes-A, B, C, D, E. Antinodes-A¹, C¹. (c) 1.41m.

15.30 (a) 348.16 ms^{-1}

(b) 336 m/s

(c) Resonance will be observed at 17cm length of air column, only intensity of sound heard may be greater due to more complete reflection of the sound waves at the mercury surface.

15.31 From the relation, $v = \frac{nv}{2L}$, the result follows.

$$\mathbf{15.32} \quad t = \left[\frac{6400 - 3500}{8} + \frac{2500}{5} + \frac{1000}{8} \right] \times 2$$

$$= 1975 \text{ s.}$$

$$= 32 \text{ minute } 55 \text{ second.}$$

$$\mathbf{15.33} \quad c = \sqrt{\frac{3P}{\rho}} = \sqrt{\frac{3RT}{M}}, v = \sqrt{\frac{\gamma P}{\rho}} = \sqrt{\frac{\gamma RT}{M}}$$

$$\frac{c}{v} = \sqrt{\frac{3}{\gamma}} \text{ and } \gamma = \frac{7}{5} \text{ for diatomic gases.}$$

15.34 (a) (ii), (b) (iv), (c) (iii), (d) (i).

15.35 (a) 5m, (b) 5m, (c) 50Hz, (d) 250ms^{-1} , (e) $500\pi \text{ ms}^{-1}$.

15.36 (a) 6.4π radian, (b) 0.8π radian, (c) π radian, (d) $3\pi/2$ radian, (e) 80π radian.

DESIGN OF QUESTION PAPER

**PHYSICS
CLASS XI**

TIME: 3 HRS.

MAX. MARKS: 70

The weightage or the distribution of marks over different dimensions of the question paper shall be as follows:

A. Weightage to content/subject units

Sr. No.	Unit	Marks
1.	Physical world and measurement	03
2.	Kinematics	10
3.	Laws of motion	10
4.	Work, Energy and Power	06
5.	Motion of system of particles and rigid body	06
6.	Gravitation	05
7.	Properties of bulk matter	10
8.	Thermodynamics	05
9.	Behaviour of perfect gas and kinetic theory of gases	05
10.	Oscillation and waves	10
	Total	70

B. Weightage to form of questions

Sr. No.	Form of Question	Marks for each question	No. of Question	Total Marks
1.	Long Answer Type (1A)	5	3	15
2.	Short Answer (SAI)	3	09	27
3.	Short Answer (SAII)/ Multiple Choice Question (MCQ)	2	10	20
4.	Very Short Answer (VSA)/ Multiple Choice Question (MCQ)	1	08	08
	Total	–	30	70

1 Mark question may be Very Short Answer (VSA) type or Multiple choice Question with only one option correct.

2 Mark question may be Short Answer (SAII) or Multiple choice Question with more than one option correct.

C. Scheme of options

1. There will be no over all option.
2. Internal choices (either for type) on a very selective basis has been given in some questions.

D. Weightage to difficulty levels of questions

Sr. No.	Estimated difficulty level	Percentage
1.	Easy	15
2.	Average	70
3.	Difficult	15

Sample Paper 1
Blue Print

Sample Question Papers

Topic	VSA (1 Mark)	SAI (2 Marks)	SA II (3 Marks)	LA (5 Marks)	Total
I Physical Work and Measurement	1 (1)	2 (1)	—	—	3 (2)
II Kinematics	1 (1)	4 (2)	—	5 (1)	10 (4)
III Laws of Motion	1 (1)	—	9 (3)	—	10 (4)
IV Work, Energy and Power	1 (1)	2 (1)	3 (1)	—	6 (3)
V Motion of System of Particles & Rigid body	1 (1)	2 (1)	3 (1)	—	6 (3)
VI Gravitation	—	2 (1)	3 (1)	—	5 (2)
VII Properties of bulk of Matter	—	2 (1)	3 (1)	5 (1)	10 (3)
VIII Thermodynamics	—	2 (1)	3 (1)	—	5 (2)
IX Behavior of Perfect gas & Kinetic Theory of gases	1 (1)	4 (2)	—	—	5 (3)
X Oscillation & Waves	2 (2)	—	3 (1)	5 (1)	10 (4)
Total	8 (8)	20 (10)	27 (9)	15 (3)	70 (30)

SAMPLE PAPER I
PHYSICS – XI

Time : Three Hours

Max. Marks : 70

General Instructions

- (a) All questions are compulsory.
- (b) There are 30 questions in total. Questions 1 to 8 carry one mark each, questions 9 to 18 carry two marks each, questions 19 to 27 carry three marks each and questions 28 to 30 carry five marks each.
- (c) There is no overall choice. However, an internal choice has been provided in one question of two marks, one question of three marks and all three questions of five marks each. You have to attempt only one of the given choices in such questions.
- (d) Use of calculators is not permitted.
- (e) You may use the following physical constants wherever necessary :

$$c = 3 \times 10^8 \text{ms}^{-1}$$

$$h = 6.6 \times 10^{-34} \text{Js}$$

$$\mu_0 = 4\pi \times 10^{-7} \text{TmA}^{-1}$$

$$\text{Boltzmann constant } k = 1.38 \times 10^{-23} \text{JK}^{-1}$$

$$\text{Avogadro's number } N_A = 6.023 \times 10^{23} / \text{mole}$$

1. If momentum (P), area (A) and time (T) are taken to be fundamental quantities, then energy has the dimensional formula
 - (a) $[P^1 A^{-1} T^1]$
 - (b) $[P^2 A^1 T^1]$
 - (c) $[P^1 A^{-1/2} T^1]$
 - (d) $[P^1 A^{1/2} T^{-1}]$
2. The average velocity of a particle is equal to its instantaneous velocity. What is the nature of its motion?
3. A Force of $\mathbf{F} = (6\mathbf{i} - 3\mathbf{j}) \text{N}$ acts on a mass of 2kg. Find the magnitude of acceleration.
4. The work done by a body against friction always results in
 - (a) loss of kinetic energy
 - (b) loss of potential energy
 - (c) gain of kinetic energy
 - (d) gain of potential energy.

5. Which of the following points is the likely position of the centre of mass of the system shown in Fig. 1.

- (a) A
 (b) B
 (c) C
 (d) D

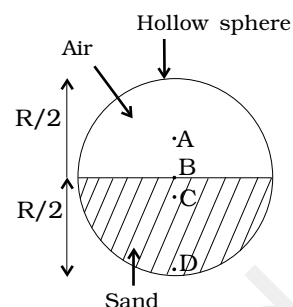

Fig. 1

6. Two molecules of a gas have speeds 9×10^6 m/s and 1.0×10^6 m/s, respectively. What is the r.m.s. speed?
7. A particle in S.H.M has displacement x given by $x = 3 \cos (5\pi t + \pi)$ where x is in metres and t in seconds. Where is the particle at $t = 0$ and $t = 1/2$ s?
8. When the displacement of a particle in S.H.M. is one-fourth of the amplitude, what fraction of the total energy is the kinetic energy?
9. The displacement of a progressive wave is represented by $y = A \sin(\omega t - kx)$, where x is distance and t is time.

Write the dimensional formula of (i) ω and (ii) k .

10. 100 g of water is supercooled to -10°C . At this point, due to some disturbance mechanised or otherwise some of it suddenly freezes to ice. What will be the temperature of the resultant mixture and how much mass would freeze?

$$[S_w = 1\text{cal/g/}^\circ\text{C and } L_{\text{Fusion}}^w = 80\text{cal/g}]$$

OR

One day in the morning to take bath, I filled up $1/3$ bucket of hot water from geyser. Remaining $2/3$ was to be filled by cold water (at room temperature) to bring the mixture to a comfortable temperature. Suddenly I had to attend to some work which would take, say 5-10 minutes before I can take bath. Now I had two options: (i) fill the remaining bucket completely by cold water and then attend to the work; (ii) first attend to the work and fill the remaining bucket just before taking bath. Which option do you think would have kept water warmer? Explain.

11. Prove the following;
 For two angles of projection ' θ ' and $(90-\theta)$ (with horizontal) with same velocity ' V '
- (a) range is the same,
 (b) heights are in the ratio: $\tan^2 \theta : 1$.
12. What is meant by 'escape velocity'? Obtain an expression for escape velocity of an object projected from the surface of the earth.

13. A fighter plane is flying horizontally at an altitude of 1.5 km with speed 720 km/h. At what angle of sight (w.r.t. horizontal) when the target is seen, should the pilot drop the bomb in order to hit the target?

14. A sphere of radius R rolls without slipping on a horizontal road. A, B, C and D are four points on the vertical line through the point of contact 'A' (Fig.2). What are the translational velocities of particles at points A, B, C, D? The velocity of the centre of mass is V_{cm} .

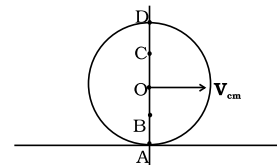

Fig. 2

15. A thermodynamic system is taken from an original state D to an intermediate state E by the linear process shown in the Fig. 3.

Its volume is then reduced to the original value from E to F by an isobaric process. Calculate the total work done by the gas from D to E to F.

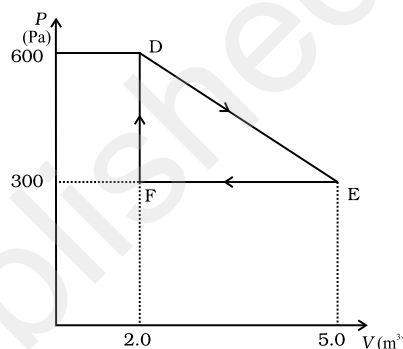

Fig. 3

16. A flask contains Argon and Chlorine in the ratio 2:1 by mass. The temperature of the mixture is 37°C . Obtain the ratio of (i) average kinetic energy per molecule and (ii) root mean square speed V_{rms} of the molecules of the two gases. Atomic mass of argon = 39.9u; molecular mass of chlorine = 70.9u.
17. Calculate the root mean square speed of smoke particles of mass 5×10^{-17} kg in Brownian motion in air at NTP?
18. A ball with a speed of 9m/s strikes another identical ball at rest such that after collision the direction of each ball makes an angle 30° with the original direction. Find the speed of two balls after collision. Is the kinetic energy conserved in this collision process?
19. Derive a relation for the maximum velocity with which a car can safely negotiate a circular turn of radius r on a road banked at an angle θ , given that the coefficient of friction between the car tyres and the road is μ .
20. Give reasons for the following:-
 (a) A cricketer moves his hands backwards while holding a catch.
 (b) It is easier to pull a lawn mower than to push it.
 (c) A carpet is beaten with a stick to remove the dust from it.
21. A helicopter of mass 1000 kg rises with a vertical acceleration of 15 m s^{-2} . The crew and the passengers weight 300 kg. Give the magnitude and direction of the
 (a) force on the floor by the crew and passengers,
 (b) action of the rotor of the helicopter on the surrounding air,
 (c) force on the helicopter due to the surrounding air.
22. A woman pushes a trunk on a railway platform which has a rough surface. She applies a force of 100 N over a distance of 10 m. Thereafter, she gets progressively tired

and her applied force reduces linearly with distance to 50 N. The total distance through which the trunk has been moved is 20 m. Plot the force applied by the woman and the frictional force, which is 50 N. Calculate the work done by the two forces over 20m.

23. Derive equations of motion for a rigid body rotating with constant angular acceleration ' α ' and initial angular velocity ω_0 .
24. Derive an expression for the kinetic energy and potential energy of a satellite orbiting around a planet. A satellite of mass 200kg revolves around a planet of mass 5×10^{30} kg in a circular orbit 6.6×10^6 m radius. Calculate the B.E. of the satellite. $G = 6.6 \times 10^{-11} \text{ Nm}^2 / \text{kg}^2$.
25. State and prove Bernoulli's theorem.
26. Consider a cycle tyre being filled with air by a pump. Let V be the volume of the tyre (fixed) and at each stroke of the pump $\Delta V (\ll V)$ of air is transferred to the tube adiabatically. What is the work done when the pressure in the tube is increased from P_1 to P_2 ?

OR

In a refrigerator one removes heat from a lower temperature and deposits to the surroundings at a higher temperature. In this process, mechanical work has to be done, which is provided by an electric motor. If the motor is of 1kW power, and heat is transferred from -3°C to 27°C , find the heat taken out of the refrigerator per second assuming its efficiency is 50% of a perfect engine.

27. Show that when a string fixed at its two ends vibrates in 1 loop, 2 loops, 3 loops and 4 loops, the frequencies are in the ratio 1:2:3:4.
28. (a) Define coefficient of viscosity and write its SI unit.
(b) Define terminal velocity and find an expression for the terminal velocity in case of a sphere falling through a viscous liquid.

OR

The stress-strain graph for a metal wire is shown in Fig. 4. The wire returns to its original state O along the curve EFO when it is gradually unloaded. Point B corresponds to the fracture of the wire.

- (i) Upto what point of the curve is Hooke's law obeyed?
- (ii) Which point on the curve corresponds to the elastic limit or yield point of the wire?
- (iii) Indicate the elastic and plastic regions of the stress-strain graph.
- (iv) Describe what happens when the wire is loaded up to a stress corresponding to the point A on the graph and then unloaded gradually. In particular explain the dotted curve.

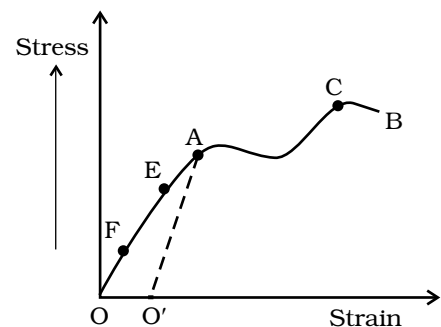

Fig. 4

- (v) What is peculiar about the portion of the stress-strain graph from C to B? Upto what stress can the wire be subjected without causing fracture?

29. It is a common observation that rain clouds can be at about a kilometre altitude above the ground.
- (a) If a rain drop falls from such a height freely under gravity, what will be its speed? Also calculate in km/h. ($g = 10\text{m/s}^2$).
- (b) A typical rain drop is about 4mm diameter. Estimate its momentum if it hits you.
- (c) Estimate the time required to flatten the drop i.e. time between first contact and the last contact.
- (d) Estimate how much force such a drop would exert on you.
- (e) Estimate to the order of magnitude force on an umbrella. Typical lateral separation between two rain drops is 5 cm.

(Assume that the umbrella cloth is not pierced through !!)

OR

A cricket fielder can throw the cricket ball with a speed v_0 . If he throws the ball while running with speed u at an angle θ to the horizontal, find

- (i) The effective angle to the horizontal at which the ball is projected in air as seen by a spectator.
- (ii) What will be time of flight?
- (iii) What is the distance (horizontal range) from the point of projection at which the ball will land?
- (iv) Find θ at which he should throw the ball that would maximise the horizontal range as found in (iii).
- (v) How does θ for maximum range change if $u > v_0$, $u = v_0$, $u < v_0$?

30. (a) Show that in S.H.M., acceleration is directly proportional to its displacement at a given instant

- (b) A cylindrical log of wood of height h and area of cross-section A floats in water. It is pressed and then released. Show that the log would execute S.H.M. with a time period,

$$T = 2\pi \sqrt{\frac{m}{A\rho g}}$$

where m is mass of the body and ρ is density of the liquid

OR

A progressive wave represented by

$$y = 5 \sin (100\pi t - 0.4\pi x)$$

where y and x are in m, t is in s. What is the

- (a) amplitude
- (b) wave length
- (c) frequency
- (d) wave velocity
- (e) magnitude of particle velocity.

© NCERT
not to be republished

SAMPLE PAPER I
SOLUTIONS AND MARKING SCHEME

1. (d) (1)
2. Uniform motion (1)
3. $\mathbf{a} = (3\hat{\mathbf{i}} - 1.5\hat{\mathbf{j}}) \text{ m/s}^2$; $|\mathbf{a}| = 3.35 \text{ m/s}^2$ (½)+(½) (1)
4. (a) (1)
5. (c) (1)
6. $6.4 \times 10^6 \text{ m/s}$ (Formula ½ , Result ½) (1)
7. -3m; 0 m. (½)+(½) (1)
8. $\frac{K.E.}{E} = \frac{15}{16}$ (Formula ½ , Ratio ½) (2)
9. (i) $[M^{\circ}L^{\circ}T^{-1}]$, (ii) $[M^{\circ}L^{-1}T^{\circ}]$ 1 + 1 (2)
10. Resultant mixture reaches 0°C. 12.5 g of ice and rest of water. (1+1)

OR

The first option would have kept water warmer because according to Newtons law of cooling the rate of loss of heat is directly proportional to the difference of temperature of the body and the surrounding. In the first case the temperature difference is less so rate of loss of heat will be less. (2)

11. Proof $R_1 = R_2$ and $\frac{h_1}{h_2} = \frac{\tan^2 \theta}{1}$ 1 + 1 (2)
12. The minimum velocity of prejection of an object so that it just escapes the gravitational force of the planet from which its is projected. (1)

$$\frac{1}{2}mv^2 = \frac{GMm}{R_e} \text{ or } v = \sqrt{\frac{2GM}{R_e}} \quad (1)$$

13. Let the time taken by the bomb to hit the target be t .

$$1500 = \frac{1}{2}gt^2$$

$$\text{Or, } t = \sqrt{300} = 17.32 \text{ s} \quad (1)$$

Horizontal distance covered by the bomb = $17.32 \times v$

$$= 17.32 \times 200 = 3464\text{m.}$$

$$\therefore \tan \theta = \frac{1500}{3464}$$

$$\text{or } \theta = \tan^{-1} 0.43 \quad (1)$$

$$14. \quad v_A = v_{CM} - \omega R = 0$$

$$v_{CM} = \omega R \quad (1/2)$$

$$v_B = v_{CM} - \frac{\omega R}{2} = v_{CM} / 2 \quad (1/2)$$

$$v_C = v_{CM} + \frac{\omega R}{2} = \frac{3}{2}v_{CM} \quad (1/2)$$

$$v_D = v_{CM} + \omega R = 2v_{CM} \quad (1/2)$$

$$15. \quad \text{Work done} = \text{area under the } P\text{-}V \text{ curve} \quad (1)$$

$$= \frac{1}{2}(300)(30) = 450\text{J} \quad (1)$$

$$16. \quad \text{Since Argon and Chlorine are both at the same temperature, the ratio of their average K.E. per molecule is } 1:1 \quad (1/2)$$

$$MV_{rms}^2 = \text{K.E. per molecule} = \frac{3}{2}kT. \quad (1/2)$$

$$\therefore \frac{V_{rms}(\text{Argon})}{V_{rms}(\text{Chlorine})} = \sqrt{\frac{M(\text{Cl})}{M(\text{Ar})}} = \sqrt{\frac{70.9}{39.9}} \\ = \sqrt{1.77} = 1.33 \quad (1/2+1/2)$$

Exemplar Problems–Physics

17. $PV = \frac{1}{3} mV_{rms}^2 = \frac{m}{M} RT$ (1)

$$V_{rms} = \sqrt{\frac{3(Nk)T}{N\mu}} = \sqrt{\frac{3kT}{\mu}} \quad (1/2)$$

$$= \sqrt{\frac{3 \times 1.38 \times 10^{-23} \times 273}{5 \times 10^{-17}}} \quad (1/2)$$

$$= 15 \times 10^{-3} \text{ m s}^{-1} \\ = 1.5 \text{ cm s}^{-1} \quad (1)$$

18. $m \times 9 = mv_1 \cos 30^\circ + mv_2 \cos 30^\circ$ (1/2)

$$0 = mv_1 \sin 30^\circ - mv_2 \sin 30^\circ \quad (1/2)$$

$$v_1 + v_2 = 6\sqrt{3}$$

$$v_1 = v_2$$

$$v_1 = v_2 = 3\sqrt{3} \text{ m s}^{-1}$$

$$T_f - T_i = \frac{1}{2} m (3\sqrt{3})^2 \times 2 - \frac{1}{2} m \times 9^2 = -13.5m \text{ joule} \quad (1/2)$$

m is mass of either balls. So, K.E. is not conserved. (1/2)

19. Diagram, derivation of relation $V = \sqrt{\frac{rg(\tan\theta + \mu)}{1 - \mu \tan\theta}}$ (1) + (2)

20. (a) He does so to increase the time taken for the catch. Since $F = Ma = M \frac{dv}{dt}$, (1)
therefore increasing the time for the catch reduces the impact of force by the ball on the hands.

(b) As seen from the figure, when the lawn mower is pulled by force \mathbf{F} at θ° to the horizontal, the horizontal component $\mathbf{F} \cos \theta$ causes translatory motion of the lawn mower while the vertical component cancels the weight of the lawn mower. (1)
If the lawn mower is pushed by a force \mathbf{F} at θ° to the horizontal, the horizontal component is again $F \cos \theta$, while the vertical component $F \sin \theta$ adds on to the weight mg , making it move difficult to push the lawn mower.

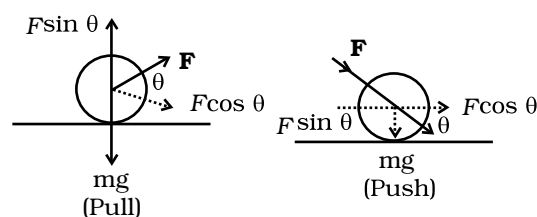

(c) By Newton's law of inertia, when the carpet is beaten by the stick, it suddenly moves forward but the dust particles tend to remain at their original positions at rest, so they fall down under gravity. (1)

21. (a) 7.5×10^3 N, downwards
 (b) 3.25×10^4 N, downwards
 (c) 3.25×10^4 N, upwards (1+1+1)

22. Work done by the women = 1750 J
 Work done by the frictional force = -1000 J (1+1+1)

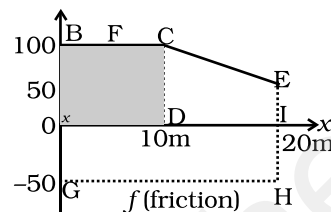

23. $\omega_f = \omega_i + \alpha t; \theta = \omega_i t + \frac{1}{2} \alpha t^2; \omega_f^2 = \omega_i^2 + 2\alpha\theta$ (1+1+1)

24. Derivation of K.E. = $\frac{GMm}{2r}$,
 P.E. = $-\frac{GMm}{r}$
 $V_b = -\frac{1}{2}mv^2 = -\frac{1}{2} \frac{GMm}{r} = -5 \times 10^{15}$ J (1+1+1)

25. Statement and proof of Bernoulli's theorem. (1 + 2)

26. $P(V + \Delta v)^\gamma = (P + \Delta p)V^\gamma$
 $P \left[1 + \gamma \frac{\Delta v}{V} \right] = P \left(1 + \frac{\Delta p}{P} \right)$ (1)

$$\gamma \frac{\Delta v}{V} = \frac{\Delta p}{P}; \frac{dv}{dp} = \frac{V}{\gamma P}$$

$$\text{W.D.} = \int_{P_1}^{P_2} P dv = \int_{P_1}^{P_2} P \frac{V}{\gamma P} dp = \frac{(P_2 - P_1)}{\gamma} V$$
 (2)

OR

$$\eta = 1 - \frac{270}{300} = \frac{1}{10}$$
 (1)

$$\text{Efficiency of refrigerator} = 0.5\eta = \frac{1}{20}$$
 (1)

If Q is the heat/s transferred at higher temperature

then $\frac{W}{Q} = \frac{1}{20}$ or $Q = 20W = 20\mu\text{KJ}$

and heat removed from lower temperature = 19 kJ. (1)

27. From the relation, $v = \frac{nv}{2L}$, the result follows.

Calculation of ratio of frequencies: $\left(\frac{1}{2} + \frac{1}{2} + \frac{1}{2} + \frac{1}{2} + 1\right)$

28. (a) Coefficient of viscosity for a fluid is defined as the ratio of shearing stress to the strain rate:

$$\mu = \frac{F/A}{v/l} = \frac{Fl}{vA} \quad (1)$$

SI unit of viscosity is poiseuille (Pl) (½)

(b) Terminal velocity is the constant maximum velocity attained by a body falling through a viscous fluid when viscous force nullifies the net downward force.

(1)

Derivation of $v_T = \frac{2}{9} r^2 \frac{(\rho - \rho_L)}{\eta}$ (2½)

OR

- (i) Upto point P. (1+1+1+1+1)
- (ii) Point E
- (iii) Elastic region : O to E
Plastic region : E to B
- (iv) Strain increases proportional to the load upto P. Beyond P, it increases by an increasingly greater amount for a given increase in the load. Beyond the elastic limit E, it does not retrace the curve backward. The wire is unloaded but returns along the dotted line AO'. Point O', corresponding to zero load which implies a permanent strain in the wire.
- (v) From C to B, strain increases even if the wire is being unloaded and at B it fractures. Stress upto that corresponding to C can be applied without causing fracture.

29. (a) $v = \sqrt{2gh} = \sqrt{2 \times 10 \times 1000} = 141\text{m/s} = 510\text{ km/h}$ (1+1+1+1+1)

(b) $m = \frac{4\pi}{3} r^3 \rho = \frac{4\pi}{3} (2 \times 10^{-3})^3 (10^3) = 3.4 \times 10^{-5} \text{ kg}$
 $P = mv \approx 4.7 \times 10^{-3} \text{ kg m/s} \approx 5 \times 10^{-3} \text{ kg m/s}$

(c) diameter $\approx 4\text{mm}$

$$\Delta t \approx d/v = 28\mu\text{s} \approx 30\mu\text{s}$$

(d) $F = \frac{\Delta P}{\Delta t} = \frac{4.7 \times 10^{-3}}{28 \times 10^{-6}} \approx 168\text{N} \approx 1.7 \times 10^2 \text{N}$

(e) A typical umbrella has 1m diameter

$$\therefore \text{Area of cross-section} = \pi d^2 / 4 \approx 0.8\text{m}^2$$

With average separation of 5cm, no. of drops that will fall almost simultaneously

$$\text{is } \frac{0.8\text{m}^2}{(5 \times 10^{-2})^2} \approx 320$$

OR

(i) $\tan^{-1} \left(\frac{v_o \sin \theta}{v_o \cos \theta + u} \right)$ (1+1/2+1+1+1/2+1/2+1/2)

(ii) $\frac{2v_o \sin \theta}{g}$

(iii) $R = \frac{2v_o \sin \theta (v_o \cos \theta + u)}{g}$

(iv) $\theta_{\max} = \cos^{-1} \left[\frac{-u + \sqrt{u^2 + 8v_o^2}}{4v_o} \right]$

(v) $\theta_{\max} = 60^\circ$ for $u = v_o$, $\theta_{\max} = 45^\circ$ for $u = 0$

$u < v_o$:

$$\theta_{\max} \approx \cos^{-1} \left(\frac{1}{\sqrt{2}} - \frac{u}{4v_o} \right) = \pi/4 \quad (\text{if } u \ll v_o)$$

$$u > v_o : \theta_{\max} \approx \cos^{-1} \frac{v_o}{u} = \pi/2 \quad (\text{if } v_o \ll u)$$

30. (a) In S.H.M. the displacement of the particle at an instant is given by

$$y = r \sin \omega t$$

$$\text{Velocity, } v = \frac{dy}{dt} = r\omega \cos \omega t$$

$$\text{Acceleration } a = \frac{dv}{dt} = -\omega^2 r \sin \omega t = -\omega^2 y \quad (1)$$

So, acceleration of a body executing S.H.M. is directly proportional to the displacement of the particle from the mean position at that instant.

(b) Let the block be pressed and let the vertical displacement at the equilibrium position be x_0 .

At equilibrium

$$mg = \text{Buoyant force}$$

$$= A \cdot x_0 \cdot \rho \cdot g$$

When it is displaced by a further displacement x , the buoyant force is $A(x_0 + x)\rho g$

Net restoring force

$$= \text{Buoyant force} - \text{weight}$$

$$= A(x_0 + x)\rho g - mg$$

$$= (A\rho g)x \text{ . i.e. proportional to } x.$$

$$\therefore T = 2\pi \sqrt{\frac{m}{A\rho g}}$$

OR

(a) 5m (b) 5m (c) 50Hz (d) 250ms^{-1} (e) $500\pi \text{ms}^{-1}$.

(1+1+1+1+1)

Sample Paper II
Blue Print

Sample Question Papers

Topic	VSA (1 Mark)	SAI (2 Marks)	SA II (3 Marks)	LA (5 Marks)	Total
I Physical Word and Measurement	1(1)	1(2)	—	—	3
II Kinematics	—	2(2)	2(3)	—	10
III Laws of Motion	—	1(2)	1(3)	1(5)	10
IV Work, Energy and Power	1(1)	1(2)	1(3)	—	6
V Motion of System of Particles & Rigid Body	—	—	2(3)	—	6
VI Gravitation	1(1)	2(2)	—	—	5
VII Properties of Bulk Modules Bulk Matter	2(1)	—	1(3)	1(5)	10
VIII Thermodynamics	2(1)	—	1(3)	—	5
IX Behavior of Perfect Gas & Kinetic Theory of Gases	1(1)	2(2)	—	—	5
X Oscillations & Wave	—	1(2)	1(3)	1(5)	10
Total					70

SAMPLE PAPER II

Time : Three Hours

Max. Marks : 70

- (a) All questions are compulsory.
- (b) There are 30 questions in total. Questions 1 to 8 carry one mark each, questions 9 to 18 carry two marks each, questions 19 to 27 carry three marks each and questions 28 to 30 carry five marks each.
- (c) There is no overall choice.
- (d) Use of calculators is not permitted.
- (e) You may use the following physical constants wherever necessary :

$$c = 3 \times 10^8 \text{ms}^{-1}$$

$$h = 6.6 \times 10^{-34} \text{Js}$$

$$\mu_0 = 4\pi \times 10^{-7} \text{TmA}^{-1}$$

$$\text{Boltzmann constant } k = 1.38 \times 10^{23} \text{JK}^{-1}$$

$$\text{Avogadro's number } N_A = 6.023 \times 10^{23} / \text{mole}$$

1. Modulus of rigidity of liquids is
 - (a) infinity; (b) zero; (c) unity; (d) some finite small non-zero constant value.
2. If all other parameters except the one mentioned in each of the options below be the same for two objects, in which case (s) they would have the same kinetic energy?
 - (a) Mass of object A is two times that of B.
 - (b) Volume of object A is half that of B.
 - (c) Object A is falling freely while object B is moving upward with the same speed at any given point of time.
 - (d) Object A is moving horizontally with a constant speed while object B is falling freely.
3. If the sun and the planets carried huge amounts of opposite charges,
 - (a) all three of Kepler's laws would still be valid.
 - (b) only the third law will be valid.
 - (c) the second law will not change.
 - (d) the first law will still be valid.

4. Which of the following pairs of physical quantities does *not* have the same dimensional formula?
- (a) Work and torque.
 - (b) Angular momentum and Planck's constant.
 - (c) Tension and surface tension.
 - (d) Impulse and linear momentum.

5. An ideal gas undergoes four different processes from same initial state (Fig.1). Four processes are adiabatic, isothermal, isobaric and isochoric. Out of A, B, C, and D, which one is adiabatic?

- (a) (B)
- (b) (A)
- (c) (C)
- (d) (D)

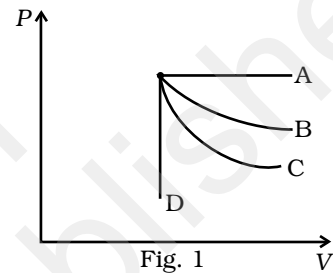

6. Why do two layers of a cloth of equal thickness provide warmer covering than a single layer of cloth of double the thickness?
7. Volume versus temperature graphs for a given mass of an ideal gas are shown in Fig 2 at two different values of constant pressure. What can be inferred about relations between P_1 & P_2 ?

- (a) $P_1 > P_2$
- (b) $P_1 = P_2$
- (c) $P_1 < P_2$
- (d) data is insufficient.

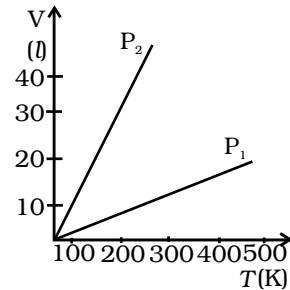

8. Along a streamline

- (a) the velocity of a fluid particle remains constant.
- (b) the velocity of all fluid particles crossing a given position is constant.
- (c) the velocity of all fluid particles at a given instant is constant.
- (d) the speed of a fluid particle remains constant.

9. State Newton's third law of motion and use it to deduce the principle of conservation of linear momentum.

10. A graph of x v/s t is shown in Fig. 3. Choose correct alternatives from below. (2)

- (a) The particle was released from rest at $t = 0$.
- (b) At B, the acceleration $a > 0$.
- (c) At C, the velocity and the acceleration vanish.
- (d) Average velocity for the motion between A and D is positive.
- (e) The speed at D exceeds that at E.

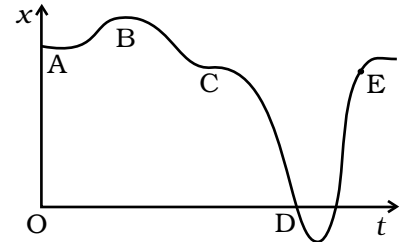
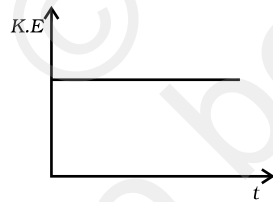

Fig. 3

11. A vehicle travels half the distance L with speed V_1 and the other half with speed V_2 then its average speed is

- (a) $\frac{V_1 + V_2}{2}$
- (b) $\frac{2V_1 + V_2}{V_1 + V_2}$
- (c) $\frac{2V_1 V_2}{V_1 + V_2}$
- (d) $\frac{L(V_1 + V_2)}{V_1 V_2}$

12. Which of the diagrams shown in Fig. 4 most closely shows the variation in kinetic energy of the earth as it moves once around the sun in its elliptical orbit?



(a)

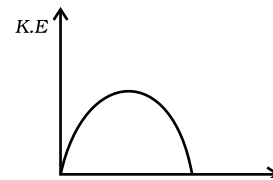

(b)

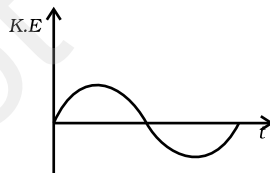

(c)

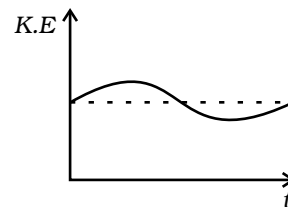

(d)

Fig. 4

13. The vernier scale of a travelling microscope has 50 divisions which coincide with 49 main scale divisions. If each main scale division is 0.5 mm, calculate the minimum inaccuracy in the measurement of distance.
14. A vessel contains two monatomic gases in the ratio 1:1 by mass. The temperature of the mixture is 27°C . If their atomic masses are in the ratio 7:4, what is the (i) average kinetic energy per molecule (ii) r.m.s. speed of the atoms of the gases.
15. A 500kg satellite is in a circular orbit of radius R_e about the earth. How much energy is required to transfer it to a circular orbit of radius $4R_e$? What are the changes in the kinetic and potential energy? ($R_e = 6.37 \times 10^6 \text{ m}$, $g = 9.8 \times \text{m s}^{-2}$.)
16. A pipe of 17 cm length, closed at one end, is found to resonate with a 1.5 kHz source. (a) Which harmonic of the pipe resonate with the above source? (b) Will resonance with the same source be observed if the pipe is open at both ends? Justify your answer. (Speed of sound in air = 340 m s^{-1})
17. Show that the average kinetic energy of a molecule of an ideal gas is directly proportional to the absolute temperature of the gas.
18. Obtain an expression for the acceleration due to gravity at a depth h below the surface of the earth.
19. The position of a particle is given by $\mathbf{r} = 6t\hat{i} + 4t^2\hat{j} + 10t\hat{k}$ where r is in metres and t in seconds.
- (a) Find the velocity and acceleration as a function of time.
- (b) Find the magnitude and direction of the velocity at $t = 2\text{s}$.
20. A river is flowing due east with a speed 3m/s . A swimmer can swim in still water at a speed of 4 m/s (Fig. 5).
- (a) If swimmer starts swimming due north, what will be his resultant velocity (magnitude and direction)?
- (b) If he wants to start from point A on south bank and reach opposite point B on north bank,
- (i) which direction should he swim?
- (ii) what will be his resultant speed?
- (c) From two different cases as mentioned in (a) and (b) above, in which case will he reach opposite bank in shorter time?
21. (a) A raindrop of mass 1 g falls from rest, from a height of 1 km and hits the ground with a speed of 50 m s^{-1} .
- (i) What are the final K.E. of the drop and its initial P.E.?
- (ii) How do you account for the difference between the two?
- (Take $g = 10\text{ms}^{-2}$).

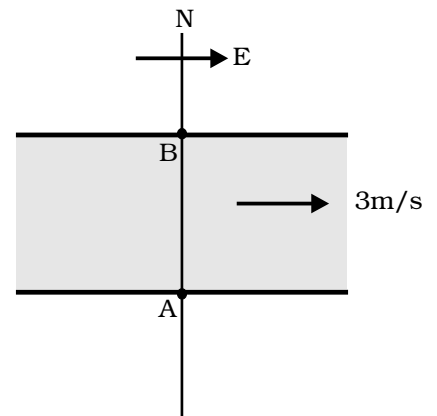

Fig. 5

- (b) Two identical ball bearings in contact with each other and resting on a frictionless table are hit head-on by another ball bearing of the same mass moving initially with a speed V as shown in Fig. 6.

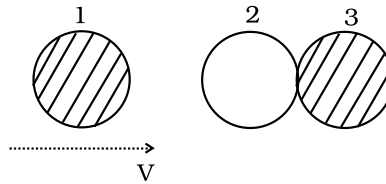

Fig. 6

If the collision is elastic, which of the following (Fig. 7) is a possible result after collision?

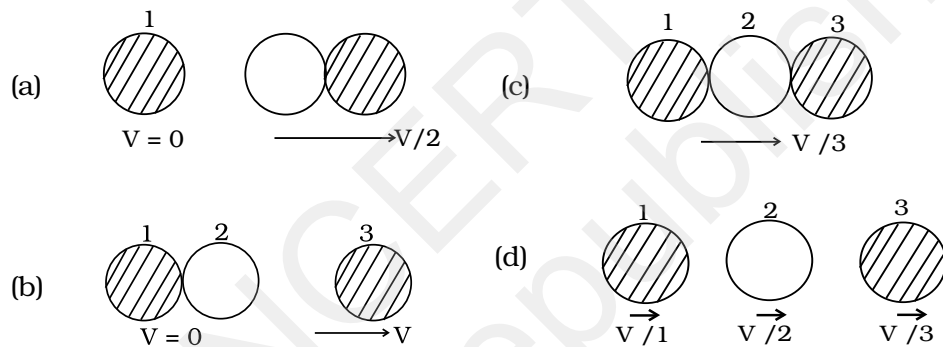

Fig. 7

22. Explain why:

- (a) It is easier to pull a hand cart than to push it.
 (b) Figure 8 shows (x, t) , (y, t) diagrams of a particle moving in 2-dimensions. If the particle has a mass of 500 g, find the force (direction and magnitude) acting on the particle.

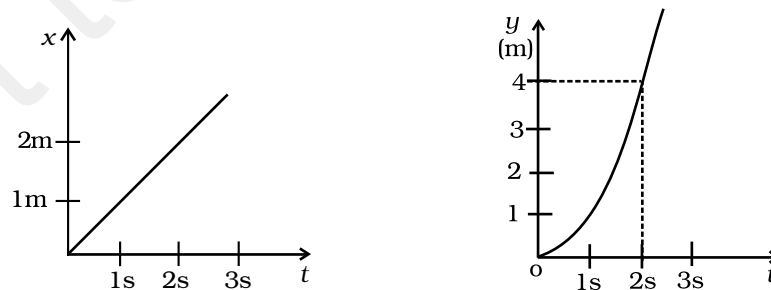

Fig. 8

23. (a) State parallel axis and perpendicular axis theorem.
- (b) Find the moment of inertia of a sphere about a tangent to the sphere, given the moment of inertia of the sphere about any of its diameters to be $\frac{2MR^2}{5}$, where M is the mass of the sphere and R is the radius of the sphere.
24. A 3m long ladder weighing 20 kg leans on a frictionless wall. Its feet rest on the floor 1 m from the wall Find the reaction forces of the wall and the floor. (3)
25. A fully loaded Boeing aircraft has a mass of 3.3×10^5 kg. Its total wing area is 500 m^2 . It is in level flight with a speed of 960km/h. (a) Estimate the pressure difference between the lower and upper surfaces of the wings. (b) Estimate the fractional increase in the speed of the air on the upper surface of the wing relative to the lower surface.
(The density of air $\rho = 1.2 \text{ kg m}^{-3}$)
26. Explain briefly the working principle of a refrigerator and obtain an expression for its coefficient of performance.
27. Derive an expression for the apparent frequency of the sound heard by a listener when source of sound and the listener both move in the same direction.
28. (a) Show that for small amplitudes the motion of a simple pendulum is simple harmonic, hence obtain an expression for its time period.
- (b) Consider a pair of identical pendulums, which oscillate independently such that when one pendulum is at its extreme position making an angle of 2° to the right with the vertical, the other pendulum is at its extreme position making an angle of 1° to the left of the vertical. What is the phase difference between the pendulums?
29. (a) What is capillary rise? Derive an expression for the height to which a liquid rises in a capillary tube of radius r .
- (b) Why small drops of a liquid are always spherical in shape.
30. (a) Derive an expression for the maximum safe speed for a car on a banked track, inclined at angle α to the horizontal. μ is the coefficient of friction between the tracks and the tyres.
- (b) A 100 kg gun fires a ball of 1kg from a cliff of height 500 m. It falls on the ground at a distance of 400m from the bottom of the cliff. Find the recoil velocity of the gun. (acceleration due to gravity = 10 m s^{-2})

SAMPLE PAPER II

SOLUTIONS AND MARKING SCHEME

1. (b) (1)
2. (e) (1)
3. (c) (1)
4. (c) (1)
5. (c)
6. Air enclosed between two layers of cloth prevents the transmission of heat from our body to outside. (1)
7. (a) (1)
8. (b) (2)
9. Statement (1)

$$\frac{d\mathbf{p}_1}{dt} = -\frac{d\mathbf{p}_2}{dt} \text{ or } \frac{d}{dt}(\mathbf{p}_1 + \mathbf{p}_2) = 0 \quad (1/2)$$

$$\Rightarrow \mathbf{p}_1 + \mathbf{p}_2 = \text{constant} . \quad (1/2)$$
10. (a), (c), (e) (2)
11. (c) (2)
12. (d) (2)
13. 0.01 mm (2)
14. (i) 1:1, (ii) 1.32:1 (2)
15. $\Delta E = 11.75 \times 10^9 \text{ J}$ (1)

$$\Delta KE = -11.75 \times 10^9 \text{ J} \quad (1/2)$$

$$\Delta PE = -23.475 \times 10^9 \text{ J} \quad (1/2)$$

16. (a) $\frac{n \times 340 \times 10^2}{4 \times 17} = 500n$, where n is the harmonic for a closed pipe. Closed pipe vibrates in 3rd harmonic with source of 1.5 KHz. (1)

(b) For a pipe open at both ends,

$$\frac{n \times 340 \times 10^2}{2 \times 17} = 10^3 n \text{ where } n \text{ is the harmonic. No integral value of } n \text{ is possible for 1.5KHz. So answer is No. (1)}$$

17. $P = \frac{1}{3} \frac{MC^2}{V}$ (1/2)

$$PV = \frac{1}{3} MC^2 = \frac{2}{3} K.E \quad (1/2)$$

$$PV = nRT \quad (1/2)$$

$$K.E \propto T \quad (1/2)$$

18. $AP = h$ (1/2)

$$g' = \frac{GM'}{(R_e - h)^2} \quad (1/2)$$

$$M' = \frac{4}{3} \pi (R_e - h)^3 \rho \quad (1/2)$$

$$g' = g \left(1 - \frac{h}{R_e} \right) \quad (1/2)$$

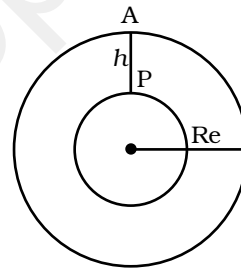

19. (a) $\mathbf{v} = 6\mathbf{i} + 8t\mathbf{j}$ (1+1+1)

$$\mathbf{a} = 8\mathbf{j}$$

(b) $\mathbf{v} = 6\mathbf{i} + 16\mathbf{j}$ or $v = \sqrt{36 + 256} = 19.8\text{m/s}$.

\mathbf{v} makes an angle of $\tan^{-1}(8/3)$ with x-axis.

20. (i) 5 m/s at 37° to N. (3)

(ii) (a) $\tan^{-1}(3/\sqrt{7})$ of N, (b) $\sqrt{7}$ m/s

(iii) in case (i) he reaches the opposite bank in shortest time.

21. (i) (a) 1.25 J , 10J

(b) Difference is due to the work done by viscous force of air

(ii) (b) (3)

22. (a) (1)

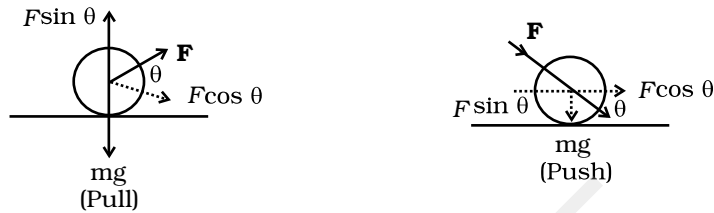

$F \sin \theta$ reduces the downward force in the case of pull.

(b) $x = t, y = t^2$

$$a_x = 0, a_y = 2 \text{ m s}^{-1}$$

$$F = 0.5 \times 2 = 1 \text{ N, along } y\text{-axis} \quad (2)$$

23. (a) Statement of parallel axis theorem (1)

(b) $\frac{7}{5} MR^2$ (Using parallel axis) (1)

Statement of perpendicular axis theorem (1)

24. Let F_1 and F_2 be the reaction forces of the wall and the floor respectively.

$$N - W = 0 \quad (3)$$

$$F - F_1 = 0 \quad (1/2)$$

$$2\sqrt{2} F_1 - (1/2) W = 0 \quad (1/2)$$

$$W = N = 20 \times 9.8 \text{ N} = 196 \text{ N}$$

$$F = F_1 = w / 4\sqrt{2} = 34.6 \text{ N} \quad (1/2)$$

$$F_2 = \sqrt{F^2 + N^2} = 199.0 \text{ N} \quad (1/2)$$

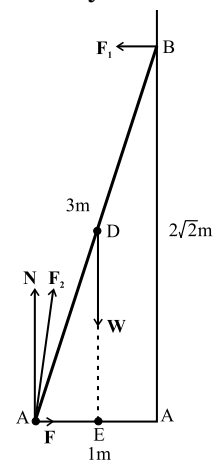

The force F_2 makes an angle α with the horizontal

$$\tan \alpha = N / F = 4\sqrt{2}, \alpha = \tan^{-1} 4\sqrt{2} \quad (1/2)$$

25. (a) The weight of the Boeing aircraft is balanced by the upwards force due to the pressure difference:

$$\Delta P \times A = 3.3 \times 10^5 \text{ kg} \times 9.8 \text{ m s}^{-2} \quad (1/2)$$

$$\Delta P = (3.3 \times 10^5 \text{ kg} \times 9.8 \text{ m s}^{-2}) / 500 \text{ m}^2 \quad (1/2)$$

$$= 6.5 \times 10^3 \text{ Nm}^{-2}$$

- (b) The pressure difference between the lower and upper surfaces of the wing is

$$\Delta P = (\rho / 2)(v_2^2 - v_1^2) \quad (1/2)$$

where v_2 is the speed of air over the upper surface and v_1 is the speed under the bottom surface.

$$v_2 - v_1 = \frac{2\Delta p}{\rho(v_2 + v_1)} \quad (1/2)$$

$$v_{av} = (v_1 + v_2) / 2 = 960 \text{ km/h} = 267 \text{ m s}^{-1} \quad (1/2)$$

$$(v_2 - v_1) / v_{av} = \Delta P / \rho v_{av}^2 \cong 0.08 \quad (1/2)$$

26. (a) Principle of reverse heat engine (1)

- (b) (1)

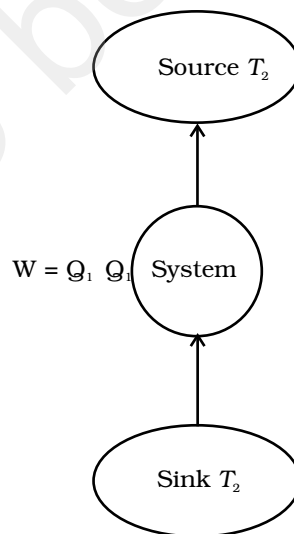

$$(c) \beta = \frac{T_2}{T_1 - T_2} \quad (1)$$

$$27. v = v_o \left(\frac{v + v_o}{v + v_s} \right) \quad (3)$$

28. (a) Diagram of simple pendulum with forces (1)

Deviation of

$$T = 2\pi \sqrt{\frac{l}{g}} \quad (2)$$

$$(b) \theta_1 = \theta_o \sin(\omega t + \delta_1)$$

$$\theta_2 = \theta_o \sin(\omega t + \delta_2)$$

$$\text{For the first, } \theta = 2^\circ, \therefore \sin(\omega t + \delta_1) = 1$$

$$\text{For the 2nd } \theta = -1^\circ, \therefore \sin(\omega t + \delta_2) = -1/2$$

$$\therefore \omega t + \delta_1 = 90^\circ, \omega t + \delta_2 = -30^\circ$$

$$\therefore \delta_1 - \delta_2 = 120^\circ \quad (2)$$

29. (a) Definition of capillary action (1)

Diagram of capillary rise (½)

Derivation (1½)

(b) Due to surface tension, liquid drops take the shape of minimum area which is sphere (2)

30. (a) Diagram (1)

Deviation of

$$\text{formula } V_s = \left[\left(\frac{\mu + \tan \alpha}{1 - \mu \tan \alpha} \right) rg \right]^{1/2} \quad (2)$$

(b) 0.4 m s^{-1} (2)

Notes

© NCERT
not to be republished

Notes

© NCERT
not to be republished